



Smart Living Project

Master Studio 4
KTH School of Architecture

together with

Semrén + Månsson

Cecile Baumann

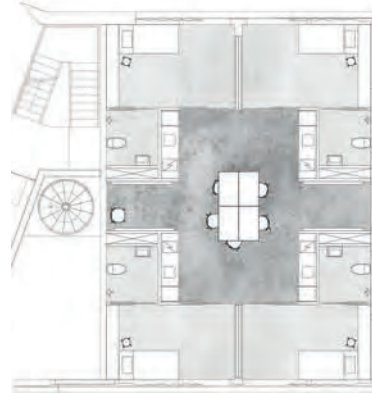
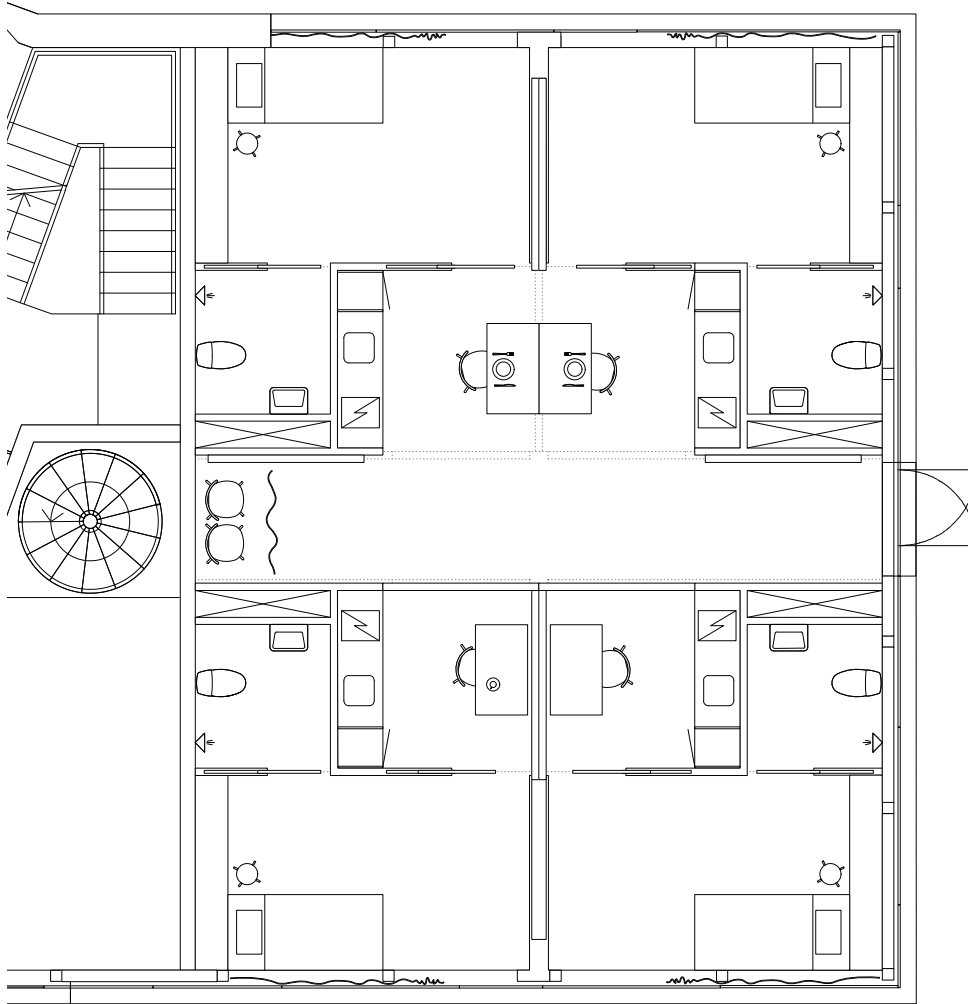

Scenario 1:
All slide doors are open, they can share a big open space that is formed in-between the kitchens

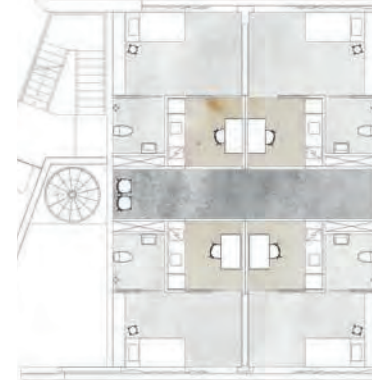

Scenario 2:
All slide doors are closed, everyone is for himself and uses his private space

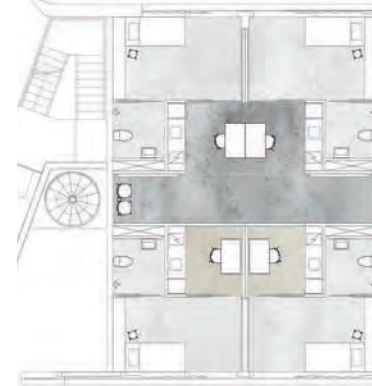

Scenario 3:
Two parts open their slide doors and share together the space in-between their kitchens

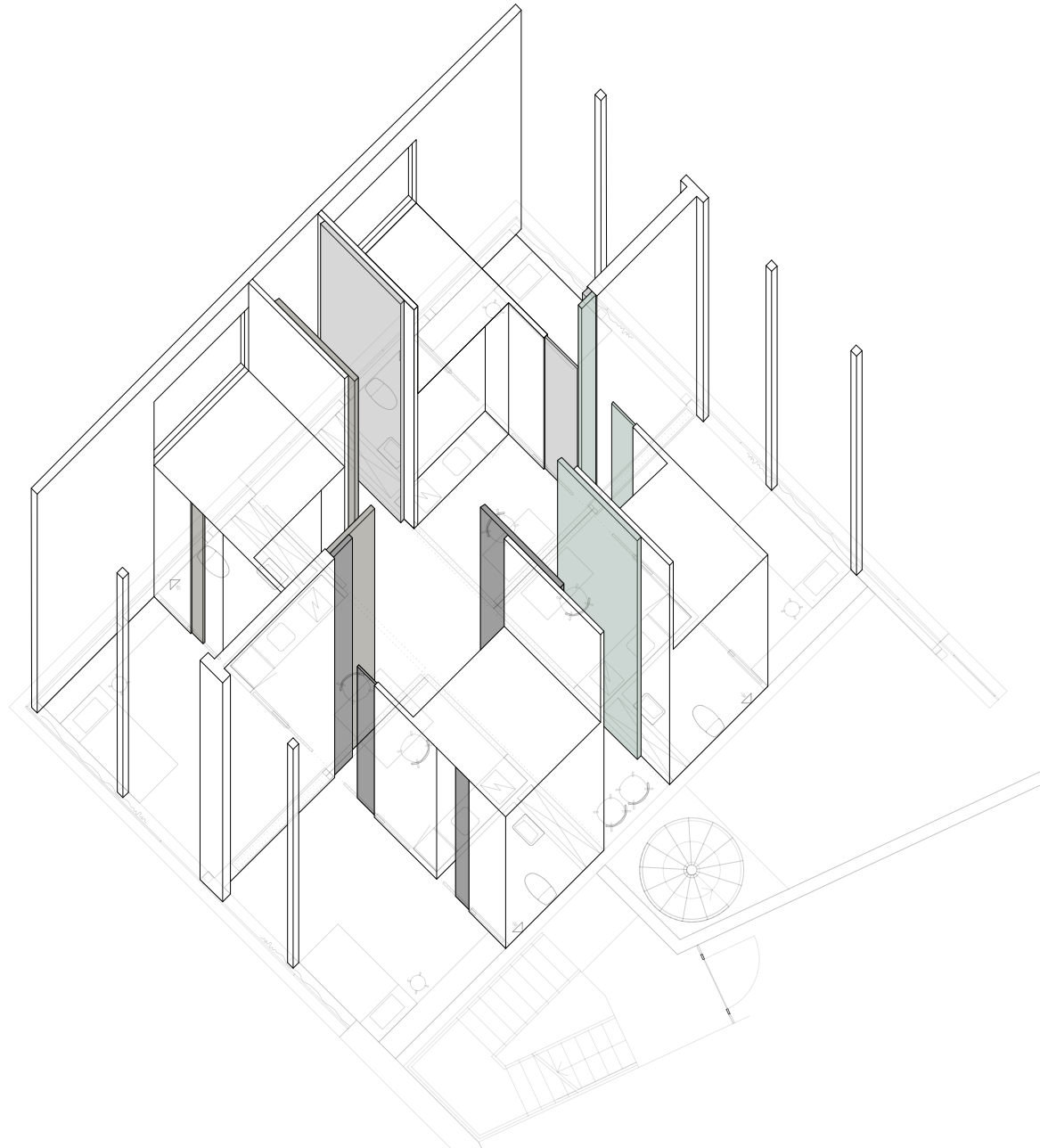

Mariana Paschidi



KTH LIVE IN LAB

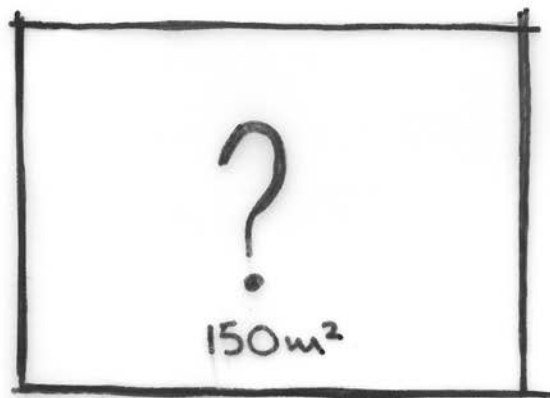

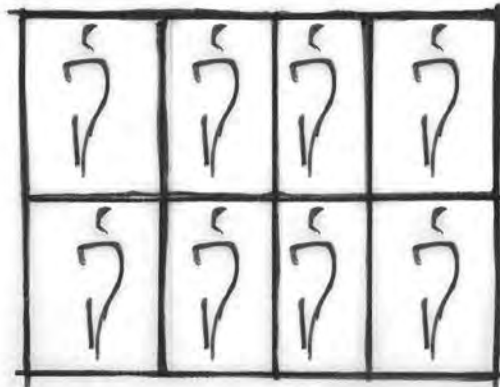
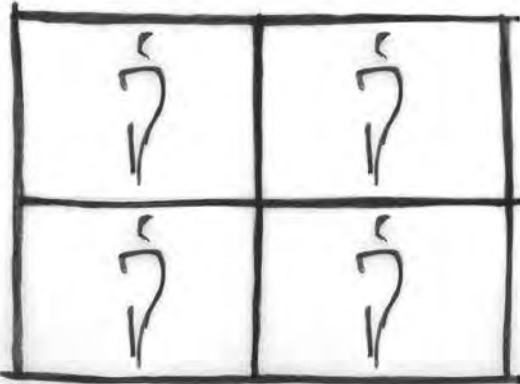
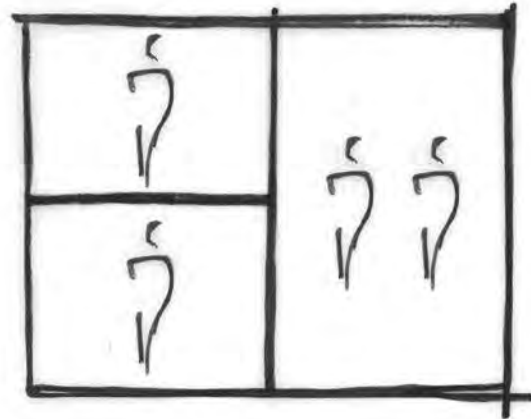
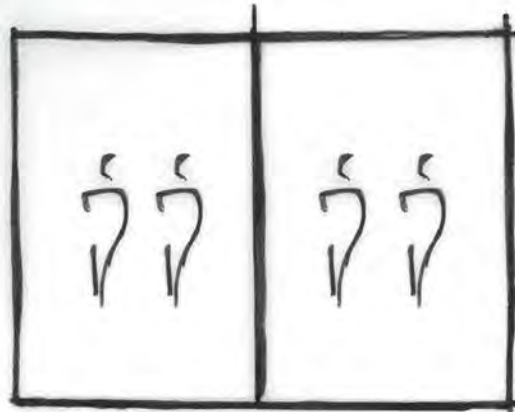
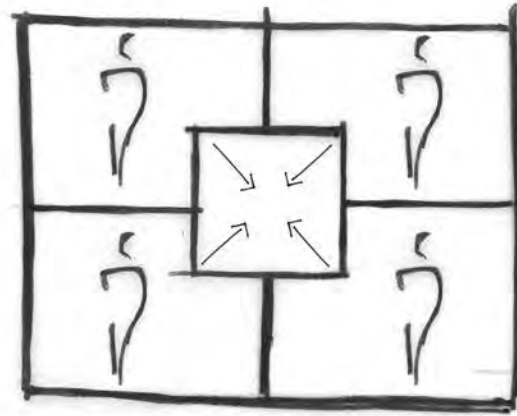
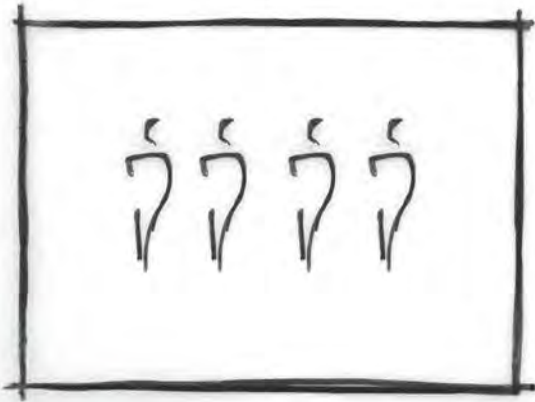

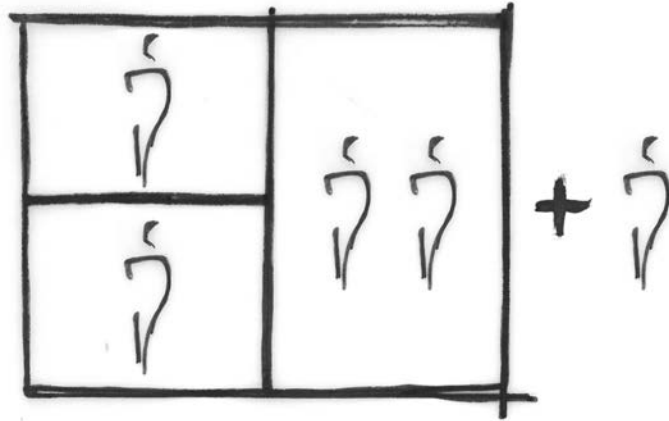

2 PRIVATE APARTMENTS
+ 1 SHARED APARTMENT

LEVELS

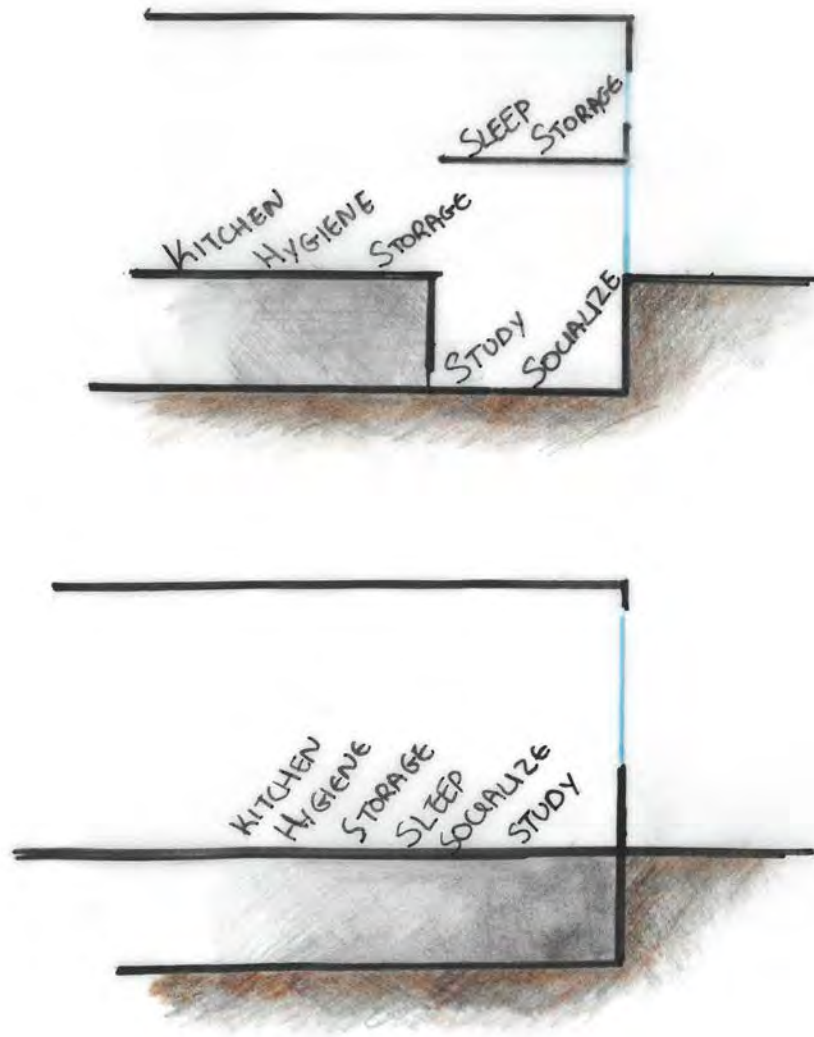

VARIOUS LEVELS = MORE SPACE
Separation of factions

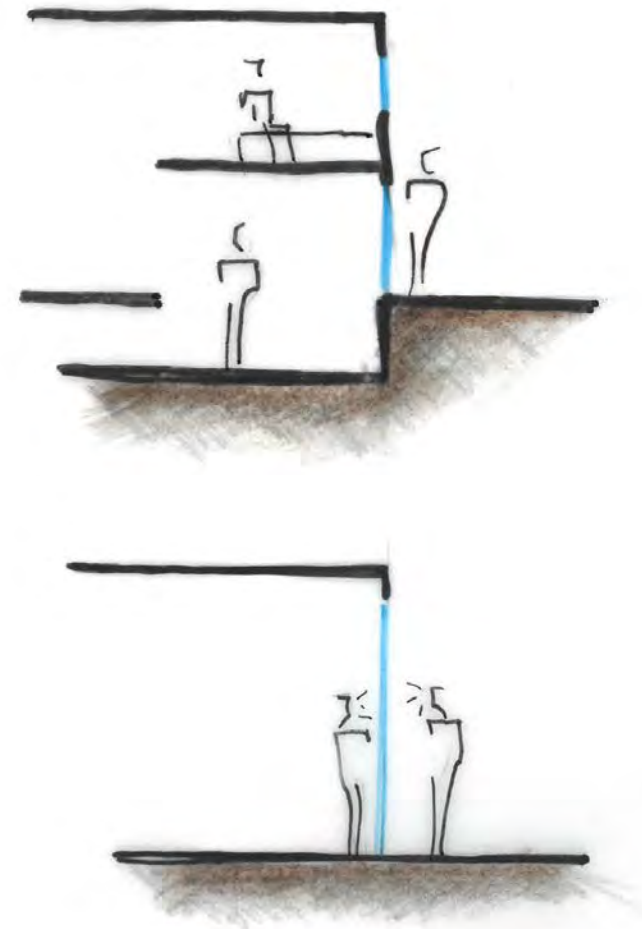

VARIOUS LEVELS \neq GROUND LEVEL
Big windows -> Privacy



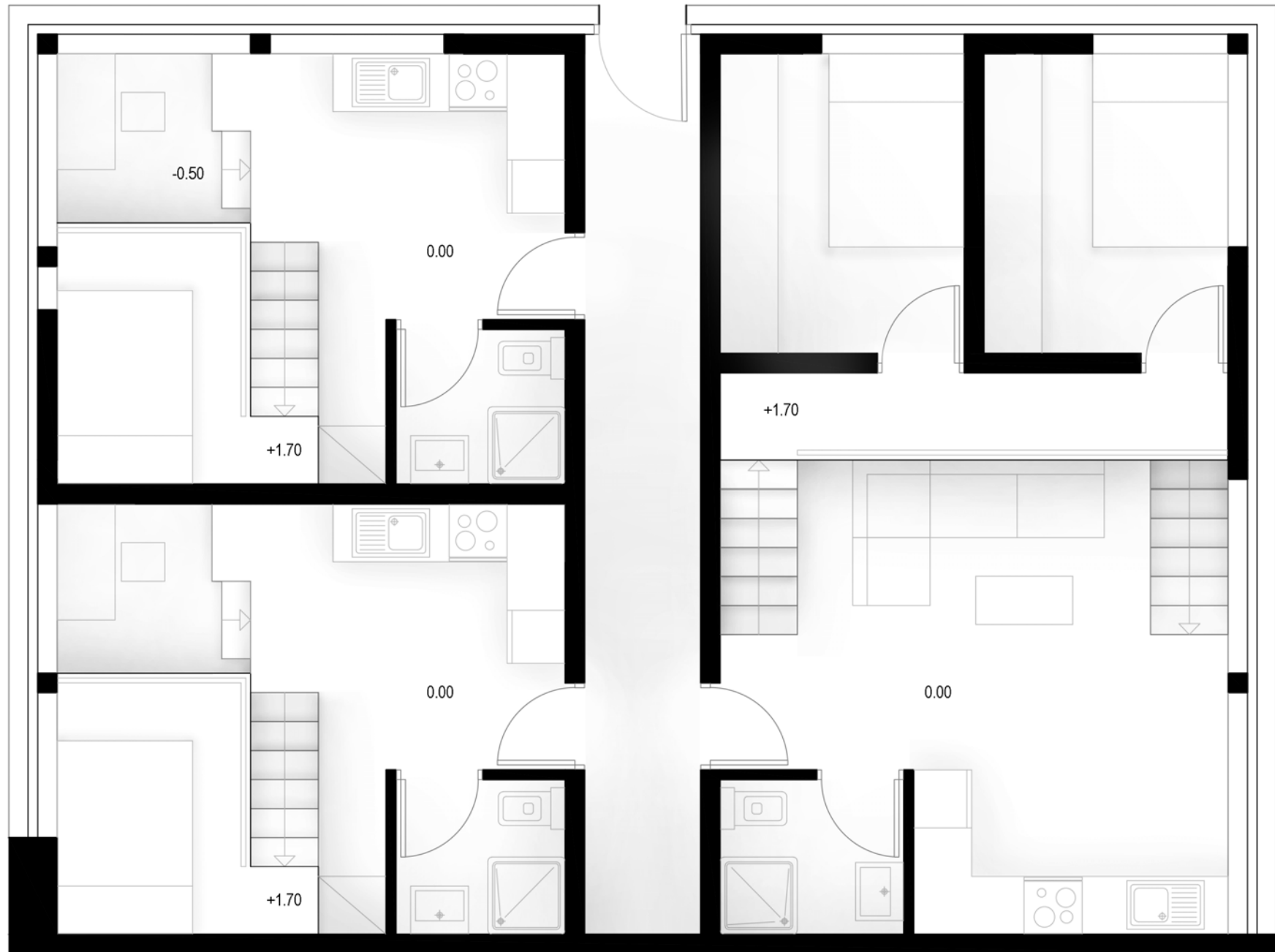

SECTION_A



SECTION_B

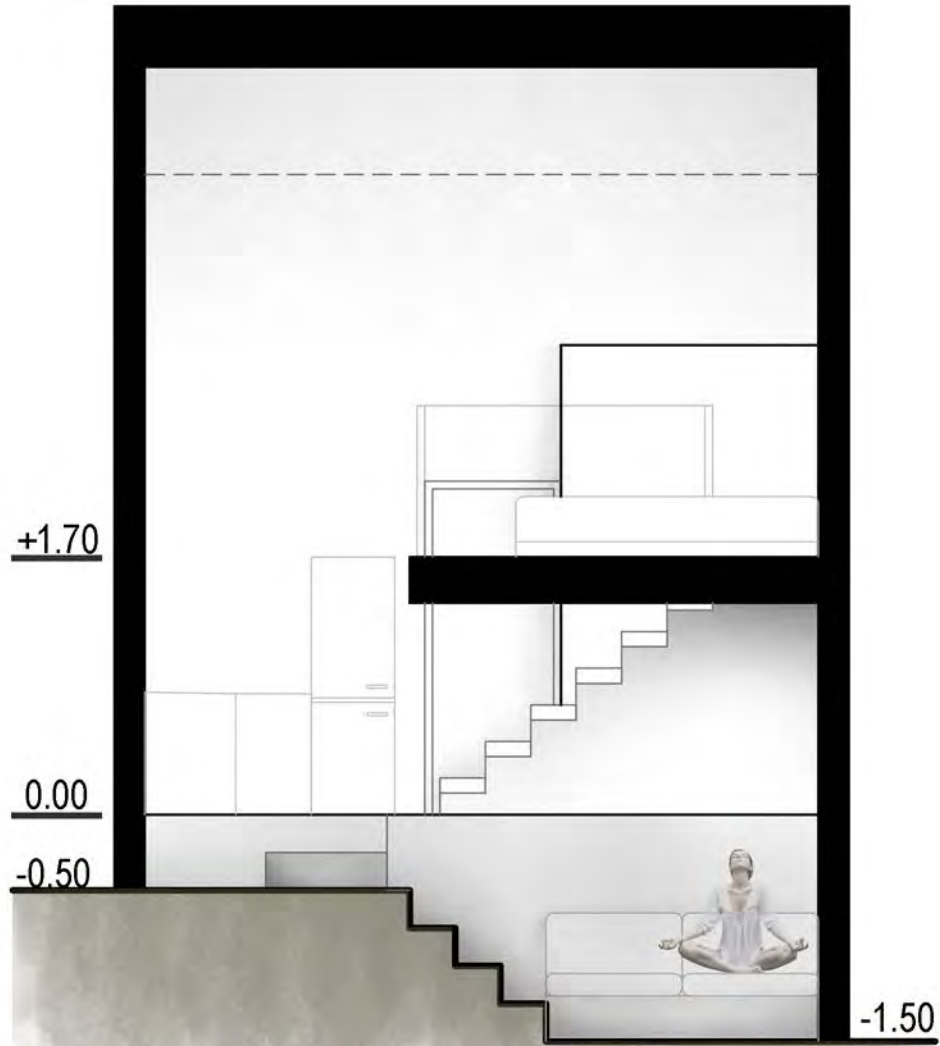

SECTION_C

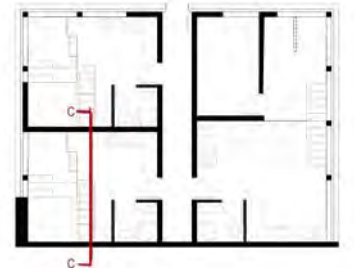
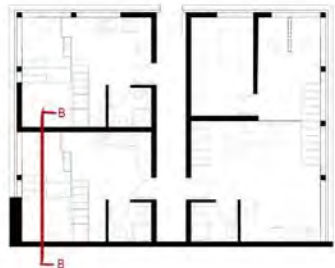
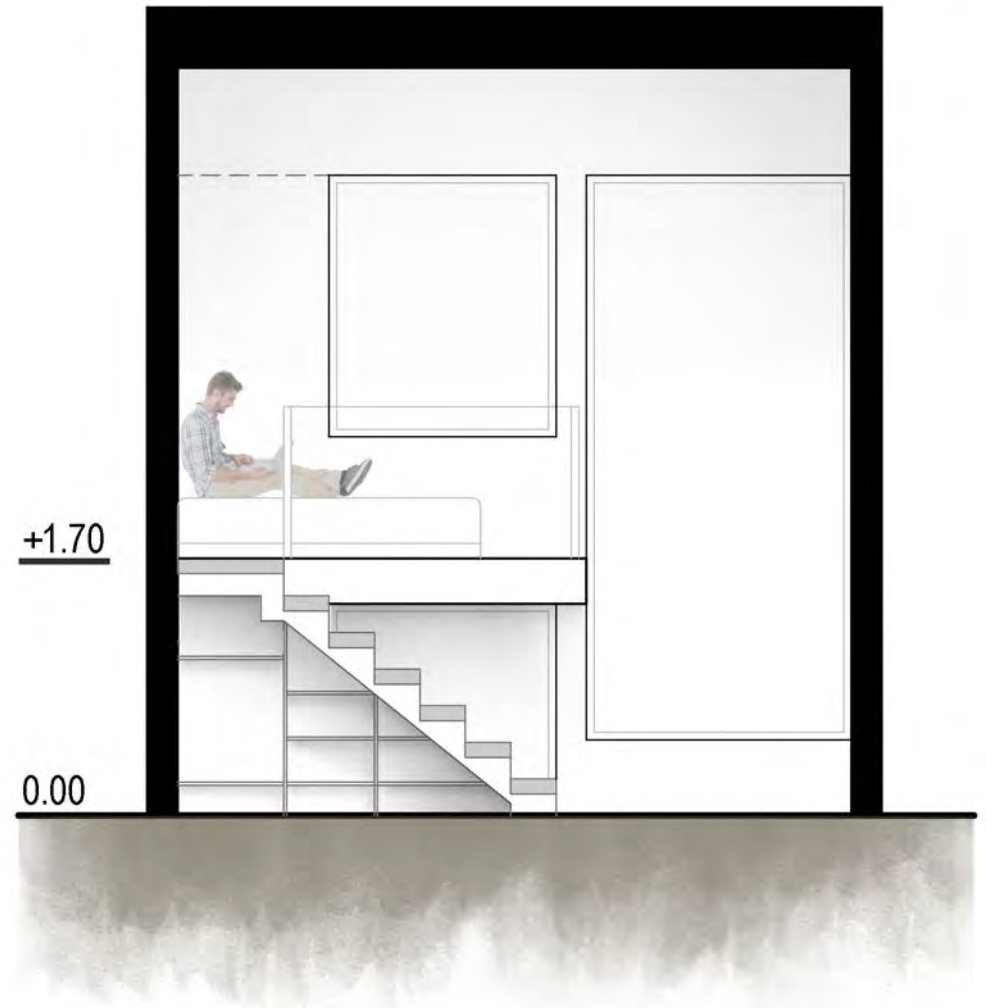

SECTION_D



Matilda Andersson

HOME IS
WHERE I
SLEEP

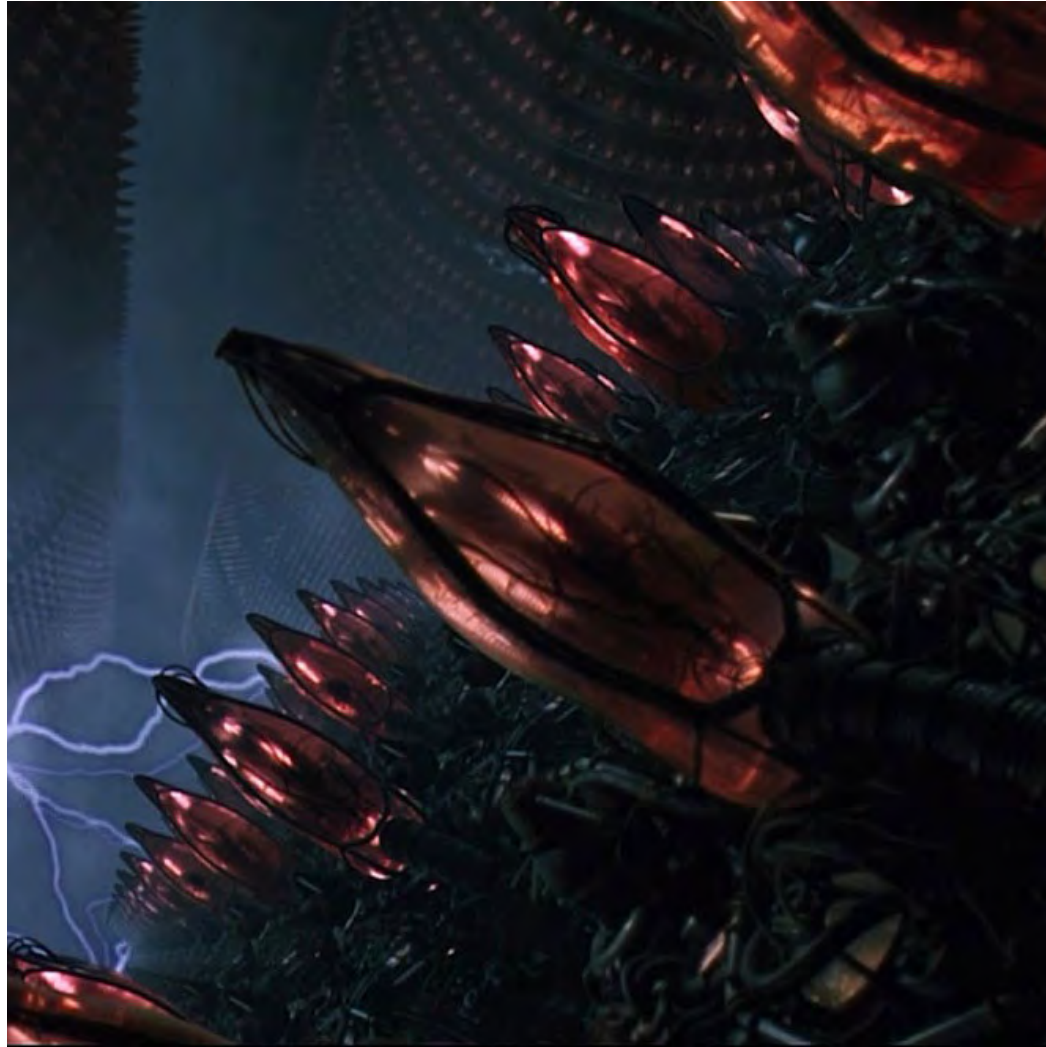









WHAT YOU NEED IN A HOME

CLASSICALLY:

SLEEP
HYGIENE
EAT
SOCIALIZE
STORAGE
ENTRANCE
WORKING
WASHING

SOME MODERN ADDITIONS (TECH):

WIFI
COMPUTER
SCREEN (COMPUTER, TV, PROJECTOR)
SOCKETS
SPEAKERS

WHAT YOU NEED IN A HOME

PRIVATE:

SLEEP
STORAGE
TECH
ENTRANCE

SHARED:

HYGIENE
EAT
SOCIALIZE
WORK
LAUNDRY

WHAT YOU NEED IN A HOME

PRIVATE:

SLEEP
STORAGE
TECH
ENTRANCE

SHARED:

HYGIENE
LAUNDRY

CITY:

EAT
SOCIALIZE
WORK



TECH AND ALL ITS WONDERFUL POTENTIAL



WHAT IS A TECH "BLANK ROOM"?

SOCKETS (LOTS OF THEM...)

USB OUTPUTS

SOUNDSYSTEM WITH AUX OUTLET

SCREENS

WIFI (A FAST ONE)

AND ALL OF IT NEEDS TO BE EASY TO
UPDATE AND CHANGE

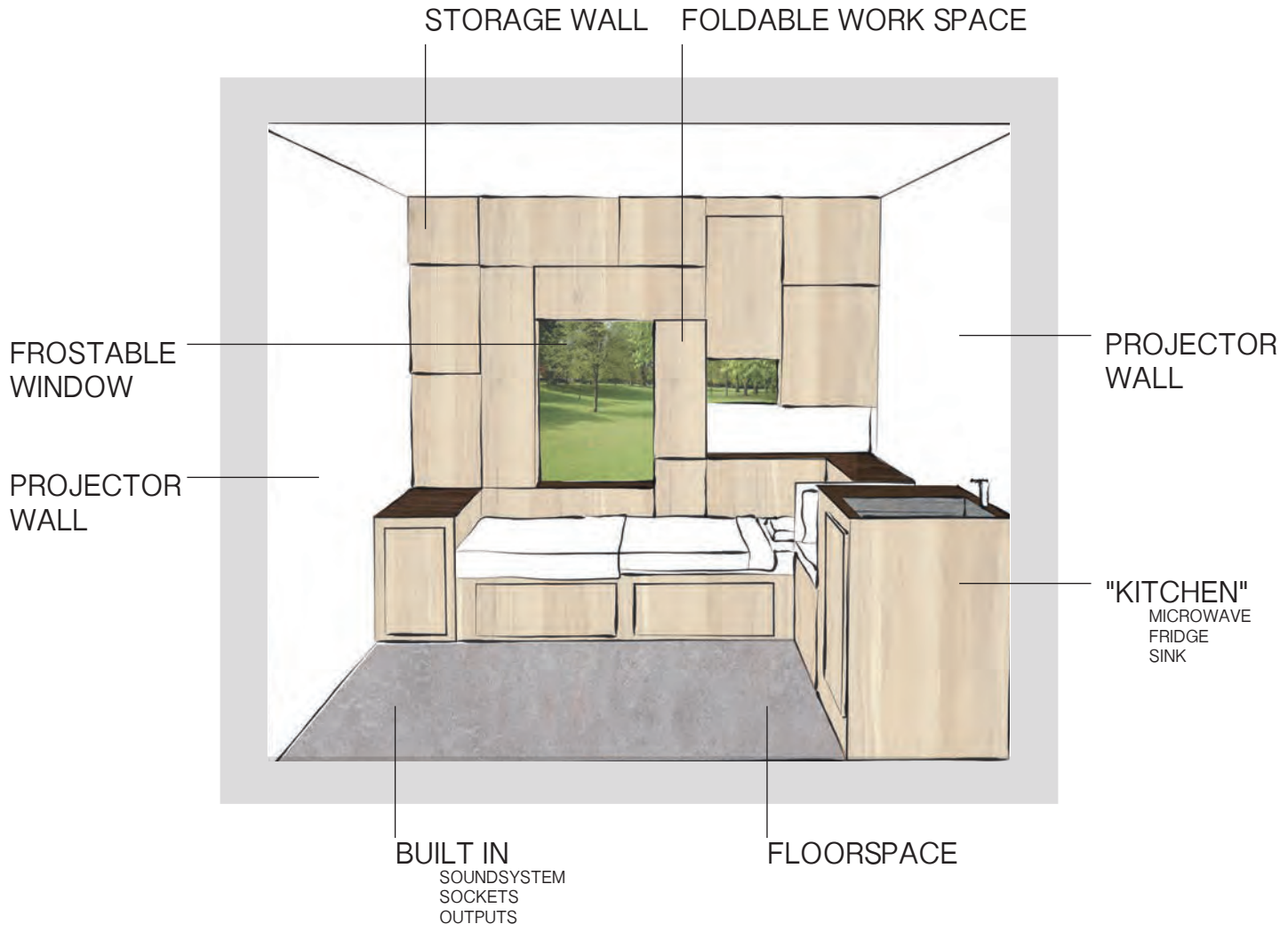

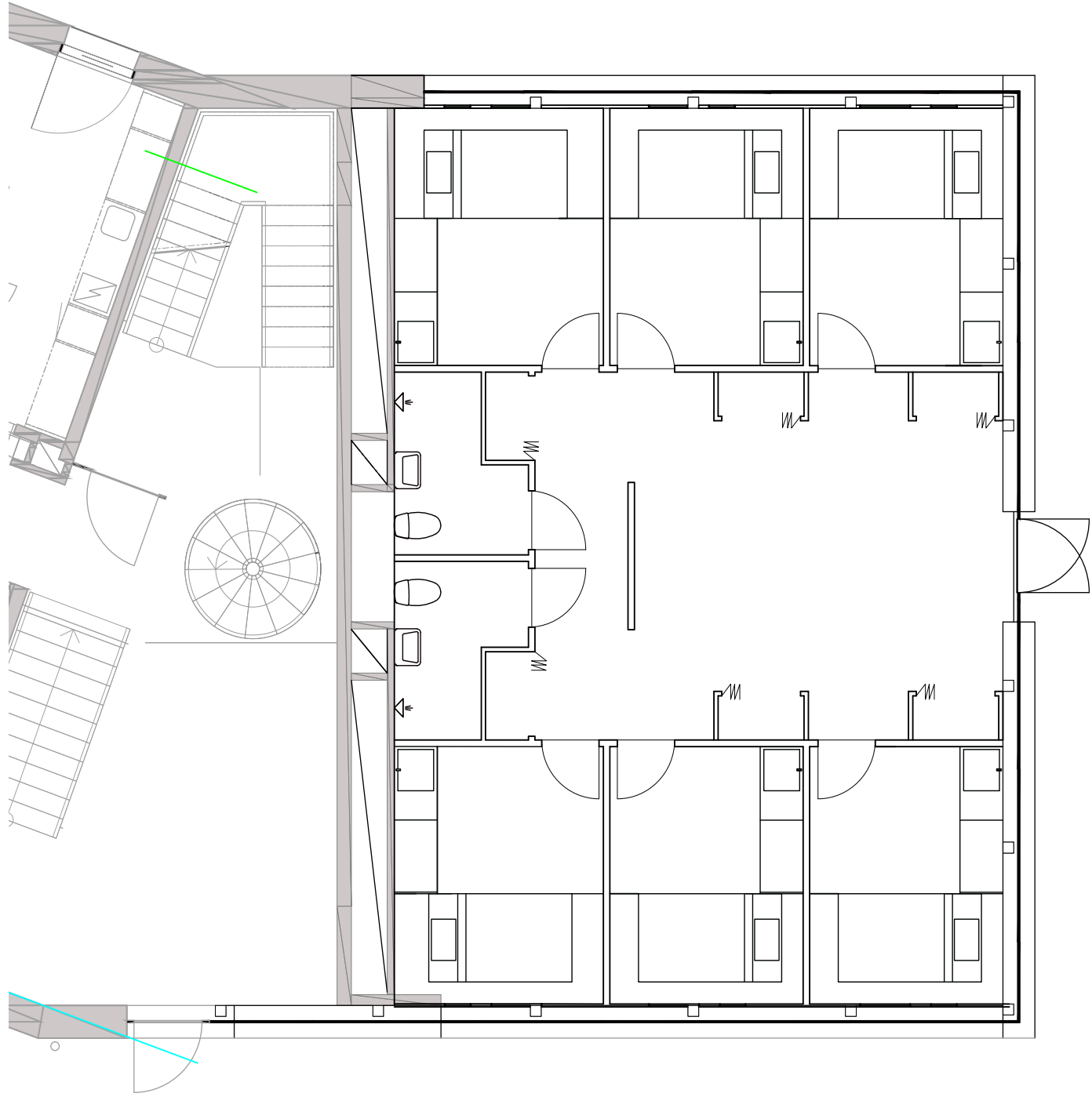

WRISTBAND

WORKS AS A KEY TO THE BATHROOM LOCKER
AND YOUR MUDRROM

CONTROLS YOUR PROJECTORS THROUGH APP

CONTROLS:

WHAT HAPPENS WHEN YOU GET HOME

PROJECTORS TURN ON

LIGHTS

HEAT

WHAT HAPPENS WHEN YOU LEAVE

LIGHTS OFF

LOWER HEAT



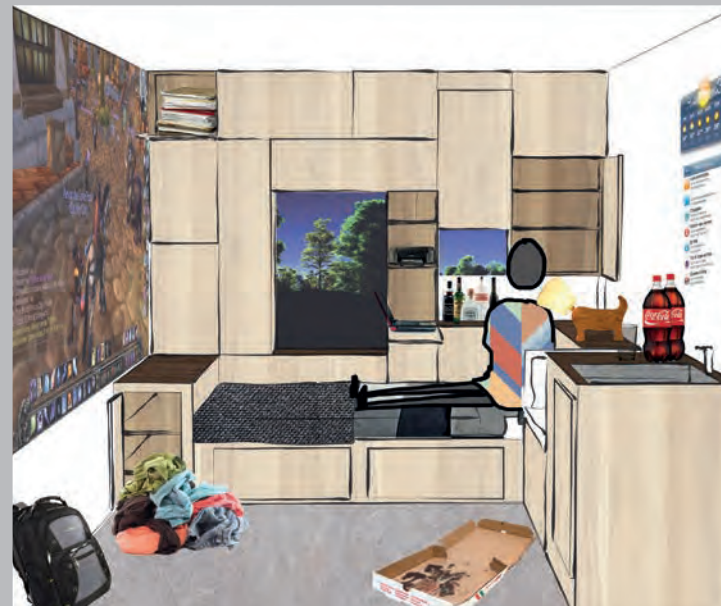
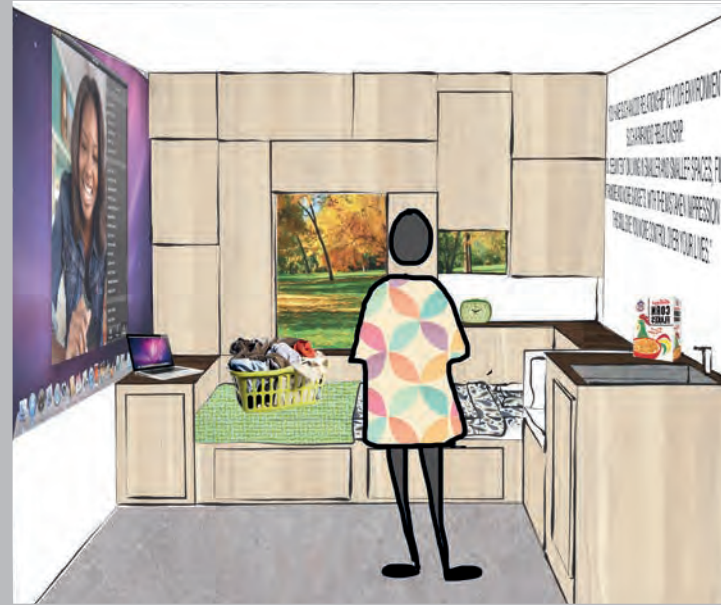

Jenny Övergaard

THOUGHTS

Thinking about challenging norms

- architecture affects the way we live, provides opportunity, becomes a stage, becomes a guidebook. it is not “un-loaded”, it says something about the way we should/can organize our lives, spend our time.

one way to look at the assignment, is to make student living that I would want to live in another to challenge the existing norms, almost for the sake of it, to show different options, (while still using experiences from living in different types of housing (for single students), for example, I know that all is possible, and actually the most important thing is a space where you are allowed to be in control and organize your time and space, the safe point from which you organize your life. because even if it is not how I would choose to live, it is necessary and part of an architect's responsibility to develop opportunities and challenge existing norms.

Typologies and their suggestions

Looking at common typologies, a few things can be realized. the most apparent: students need to sleep (alone), study at a desk (??), keep their clothes in a closet (??), go to the bathroom and shower alone, that it is a private un-sharable space?

Different ways of building suggests / reinforces different norms. What does the one today suggest? For example, suggesting a student does not have a child. Assuming we want to cook or sleep alone.

(what would different plans suggest, what if there are people that want to live in a different way that feel constrained by these norms? not that they don't fit some people, but maybe not everyone)

Thinking about shared spaces

Being in China made me realize many things that we take for granted can be challenged. In china, sleeping is a much more public thing. You share a room with four people, and sleeping at your desk or in the library or in cafés is a regular thing. It also made me realize the importance, though, of having your own space. Not in everything. It also made me realize how nice it is not to be isolated, to live with another person, especially if your family and closest friends are not in the city, especially if you don't love to network (everything is very connected to your phone, being without it makes you handicapped, then the only way to communicate is to meet people).

It also made me realize the importance of shared spaces, common rooms, to be together, especially in student housing, where most people are single, come there alone, want to spend time together, but do not really have space to do this in their rooms, as they need to respect the other person living there, and as there is no room there. also, maybe it is too personal. it is different to invite someone to your kitchen than to your bedroom.

Also; not being allowed to cook. No space to cook. Because everyone eats out. If things are located outside your house, you will live your life in a different way.

More things are shared because they need to provide cheap housing for more people. Sleep stacked, desks in line, closets too. Share bathroom, 1 per floor. Share shower, in another building. Would this be okay, like if it was a really really good shower? Perhaps we can combine like a spa-experience-social-doyourlaundry social space. maybe it would be fantastic.

Maybe not compact as goal, but rather rethinking the way we do things, and where how when we do it. perhaps also rethinking who a student is.

INTENTIONS /purpose

a general solution/something that can be tested that :

-may be applied to other situations, in other houses, when drawing (student) housing

-criticizes the current standards either by showing a new/better example, or by pulling for ex. stacking people to an extreme.

IDEAS/SUMMARIZED

BOX INSIDE BOX/COLLECTIVE

- background:

not everyone wants to live in the same way. (not ignoring that some people want to live in the standard student housing, but that exists, that doesn't need to be argued for.) this is promoting the idea that some people want to live differently, what can that look like/ how can it be provided?

The idea about the unit in the collective; opportunity to pay for what you need, not take up more space than you need, share the things you can share, or want to share.

Make boxes within the given space. Different modules combinations to choose from depending on needs and wants. High quality space, the common spaces make sure have what need. Added value.

- + would also provide, if it works, an opportunity in the future, to **rethink reconstruction projects**. - if you have a house, the structure, constructional support and infrastructure (safety, power, water), can just plug in the units. it is cheaper, as you don't have to redo the whole house.
- + easy to change after one year, not much is made "permanent"
- + mix of people

+ **IDEA THAT YOUR SPACE IS PART OF MAKING UP THE SOCIAL SPACE**

- forcing people to be affected by each other? (to have a little "own" space in a common area, and your space contributes to the making of the common space.) -- rethinking what space/activities are, how we do things.

+ **IDEA ABOUT COLLECTING INFORMATION**

collect info, record - show info, inform people living there about the way they live (on a basis that people are adaptable) - will they change the way they live? will they change the way their living actually looks? (can also be used in idea that these units would be adaptable).

+ **IDEA THAT A HOME IS NOT WHERE YOU COLLECT AND STORE YOUR THINGS. Especially as a student, not a "mini version" of a large home, but a different way of leading your life (possible to add more value that is worth something).**

Thinking about the things that you gain by living collectively.

Theorizing that as a student, the most important thing is to have a steady point to live your life from. Most students have their parents home somewhere else, this is a short term thing. You still want to have some own controll of your life (home), but it is nice with social interaction. (I think the reason most "social spaces" in student housing is not used is because you can "almost" have your own place, and don't consider the common space part of your home (often they are not so nice either, not really added value - can add value by making you feel like you actually live in the common space.

(other idea about "virtual" real space - what makes a space? can you controll other things than your things in your space? can that be a way not to focus on the things? Like being able to change the climate, the privacy or publicity of the space, the light in the space, the sound. (why do you actually need different rooms?)

If think about living in a different way, it makes sense to organize in a different way.

GAINING THROUGH SHARING, PAYING FOR WHAT YOU NEED, NOT WHAT IS PROVIDED. *or what someone else assumes you need*

Focus on the way we live vs objects that we use.

How do you live in 2016 (as a student)?

The homes relation to how you lead your life.

Change the way of thinking about "my" and "mine", (and as the home as a place to keep your things, storage for life), to a place where you live, certain needs are met, but above all you do things, interact with others. scale down to what you actually think is important, what you need for your life, not make "the normal things" smaller as a solution for students. We do not need the same things but smaller.

(the way we view a home and the "important things", and how nervous we are about sharing, or inviting people into our home, is related to the focus on collecting things, things make our lives. When everything is borrowed anyways.. on different levels. This can be visualized?

rethinking what we need and what can be shared (how we live and may live together)

THINGS WE DO

SHARE?

OBS

SLEEP(TOGETHER)

**NO (YES WITHIN FAMILIES/
COUPLES/SOME FRIENDS)**

SOUND, CLIMATE, PRIVACY

COOK/EAT

YES

LARGE ENOUGH, seating, storage

BATHROOM

MAYBE

**think about trad. family house, not
everyone private bathroom. we
know how to share. think about
japan. think about bathhouses in
istanbul. student housing in china**

SHOWER

WHY NOT - if better quality

OTHER

SOME THINGS

**DECIDE FOR YOURSELF/WITHIN THE
COLLECTIVE WHAT YOU NEED**

**FROM A HISTORICAL/TYPOLOGICAL PERSPECTIVE
(inspiration)**

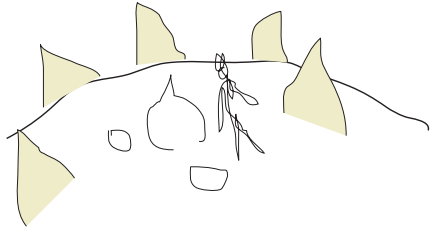

shared common space
smaller units, more private, protect against climate
share necessities

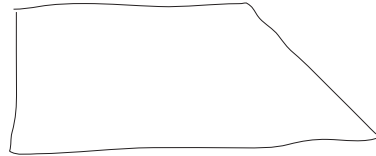
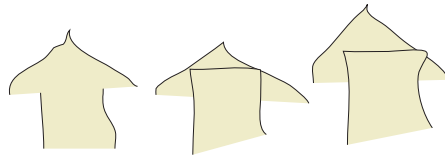

even more divided, more functions inside the house
shared common/public space outside, not used as much
for everyday things, but markets and gatherings and larger
events

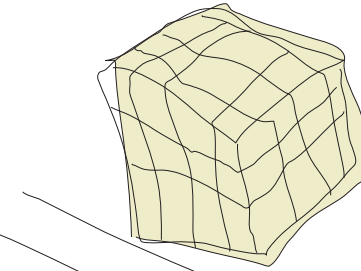

"efficient living", infrastructure is shared, functions in that way
collected, but very divided. spaces mass-produced, assum-
ing everyone has the same needs.
no common spaces? we share the space where we are
transported, where we shop. that is "society"
then we take our things back to our cube.

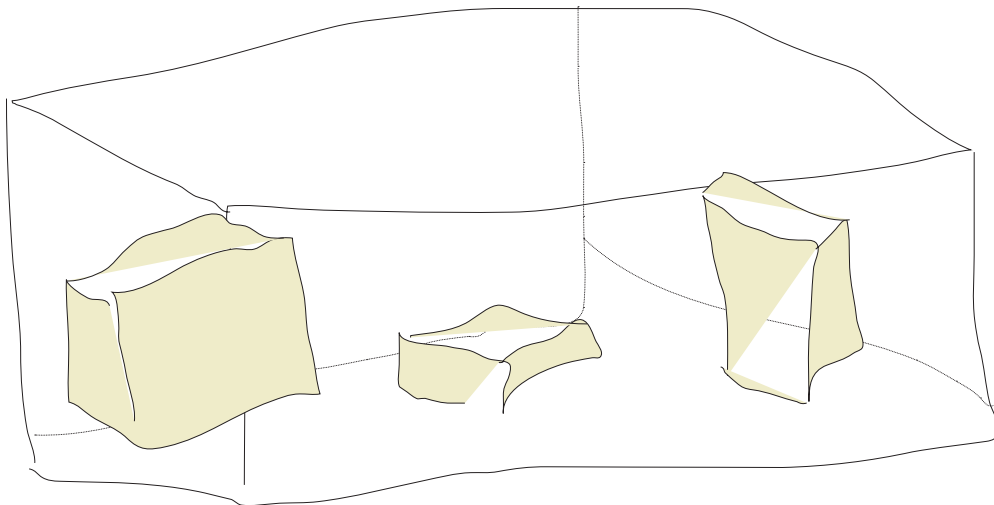

LOOKING AT EXISTING, REFERENCES
(inspiration)

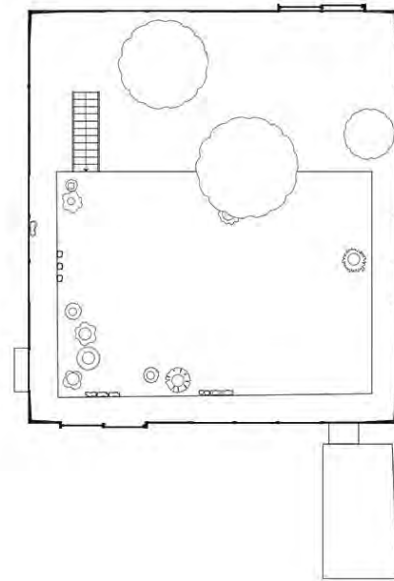
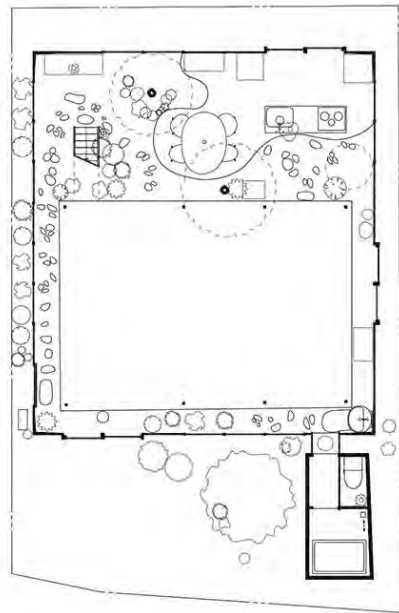

ishigami, house for young couple



UNIT EXAMPLES

STUDENT FAMILY - 2 PARENTS 1 CHILD - Need somewhere to sleep, separate bedrooms but not so big, since they both study, and spend most of their time at school anyway. Some storage for clothes. Like to have people over to hang out, would like this possibility even if they don't have a large private space...

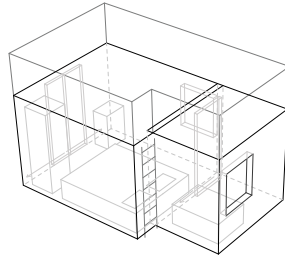

1 ART STUDENT - Studying art, and has a small space at school but prefers to work alone, and needs a dark room, working with movies and installations. Also needs a small space for storage of work-stuff. Otherwise just a space to sleep, aside from eating and other basic needs.

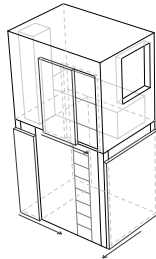

A YOUNG COUPLE - Who want to live together, but don't have enough money or ködagar to get a 2-room flat. They want privacy for the bedroom, but it can be small, and they're very flexible about how to live. They want a small space where they can hang out by themselves, they still both need some "alone time" now and then. (2 floors, top sleep, bottom space)

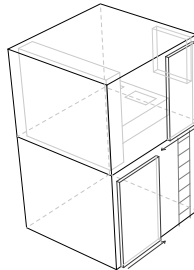

1 STUDENT - Who is tired of not finding cheap flats but really wants to study in the city. Thinks it's unnecessary with all the space, that the money is not worth it, and would rather save the money to travel. Only needs a space to sleep basically, and would live in a tent in the forest if possible.

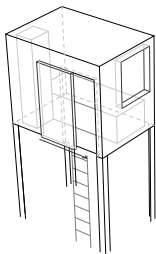

1-100 (A3)

DECIDE WHAT YOU NEED/WHAT YOU WANT TO PAY REALISE THAT YOU AND YOUR SPACE AFFECTS THOSE AROUND YOU RE-EVALUATING WHAT CAN BE SHARED AND WHAT IS PRIVATE

for some people watching tv or bathing is private. others would rather have it as a social thing. Student apartments today are all based on the same thing, and all feel like a "mini-version" of a conventional "grown-up" apartment. Many students pay more than they want for things they feel that they don't need, because the law says they should have it. As a result, it is more expensive to build, and less students have a place to live. And as a result of that, many students constantly live in crisis, rent i 2a hand, have less control of their lives and less possibility to focus on their studies, and often live under conditions

the system which is meant to set a standard for lives if it worked, does this for a few students, while the rest are exposed, and rather become victims of the system that was supposed to ensure a quality of life for them.

change the way we build to change (affect) the system?
provide options

cost:

***base cost for kollektiv and use of common spaces
(cost is adjusted depending on other tenants.**

***volume of unit, half price for "your area" that is not defined by walls, ex roof terrace.**

***the electricity heating cooling etc consumed by your unit.**

**rules: every bedroom a window, towards the glass wall.
every person living there has space for a bed that suits their size.**

8 PEOPLE
(twice as many)

cheaper rent, pay for what you want/need

opportunity to live life differently
"out of the box" in the box

- + spa
- + studyspace
- + indorr&outdorr garden
- + veranda
- + big kitchen
- + livingroom
- + company/interesting living environment
- + more storage space

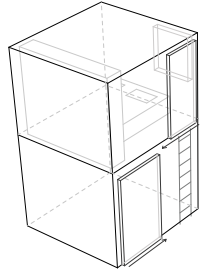
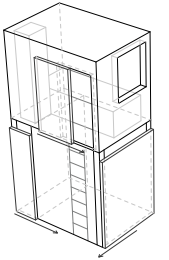
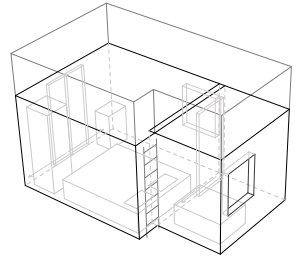

1-100 (A3)

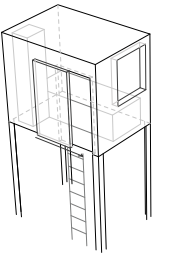

ABOUT FORM

THE OPPORTUNITIES
THE MEASURABILITY

MORE USABLE SPACE - pull your wall and become part of the rest of the space

MORE ADJUSTABLE SPACE

CAN BE PART OF STRUCTURE

CAN BE MORE "EFFICIENTLY" USED, EX BED (NO SPECIAL-PRODUCED, THEREFORE CHEAPER)

CHEAPER TO PRODUCE STRAIGHT WALLS, FASTER TO BUILD

EASIER TO CALCULATE

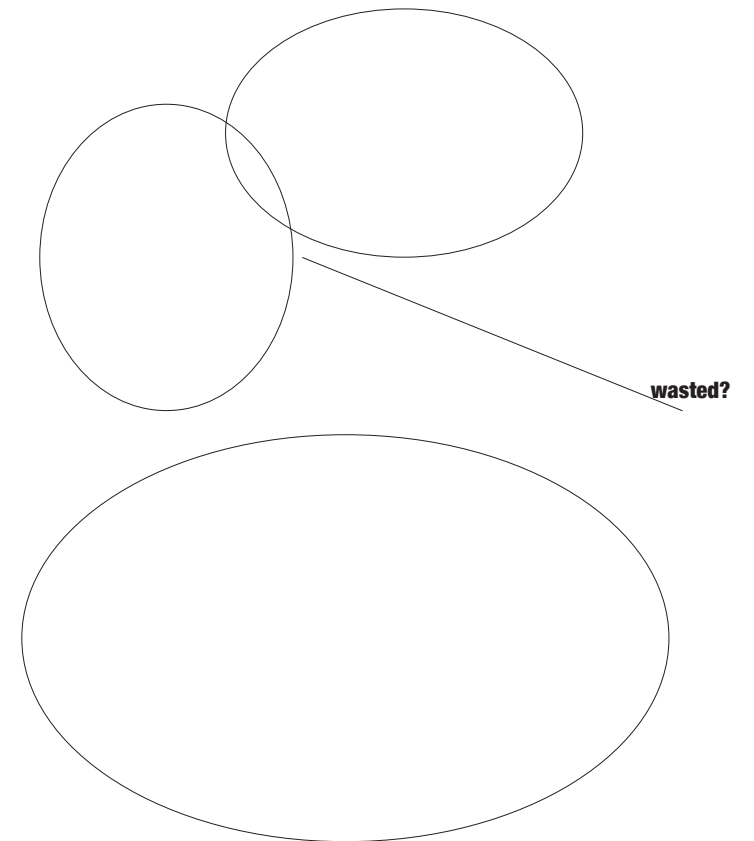
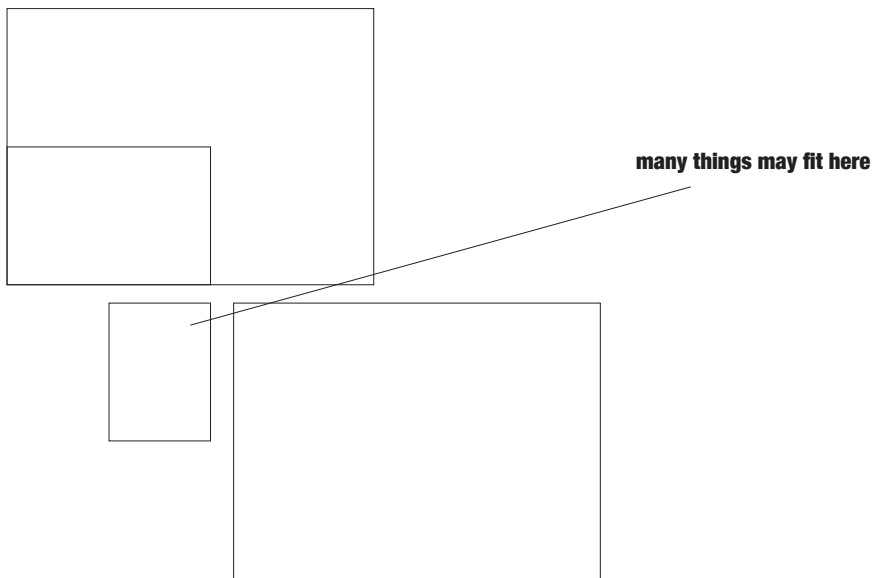

ABOUT CONSTRUCTION

BOX IN COLLECTIVE

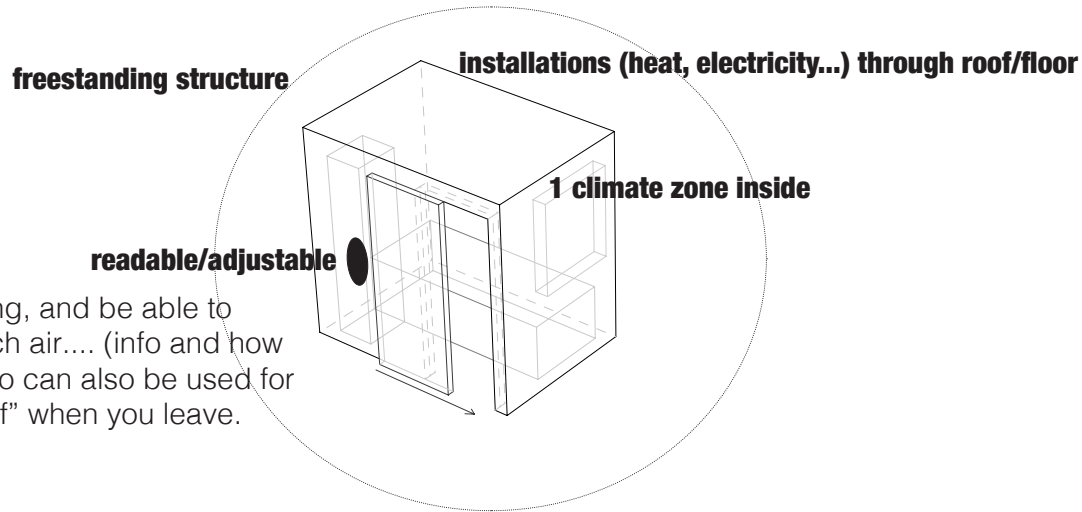

- get info about your own living, and be able to adjust it. How warm, how much air.... (info and how people are affected by the info can also be used for reserach). Possible to "turn off" when you leave.

Make boxes within the given space. Different modules combinations to choose from depending on needs and wants. High quality space, the common spaces make sure have what need. Added value by sharing.

ABOUT MONEY

WHAT DO YOU WANT TO PAY FOR

- **COLLECTIVE, BASE COST** (ADJUSTED ACCORDING TO HOW MUCH VOLUME IS TAKEN UPP BY RENTERS, wifi and other services included)
 - **VOLUME YOU WANT** (MAXIMUM) + NR OF PEOPLE? SHOULD IT MATTER? other people are affected by how many people, on the other hand, you are living on the same space, should be able to decide for yourselves?... could it be a very low cost, but still symbolic?
 - **energy you use in your unit** - heating/cooling...
- (Set a minimum space for a unit and a maximum space (because otherwise value decreases), as well as min. people live in the collective)**

An important thing to decide and set is the minimum that the collective is.

PARAMETRAR

rules about the common space

- amount of window area not covered
- area for kitchen
- area for unspecified hainging out/activity
- area for spa, number of toilets and showers (per person?)

units:

each one min. 1 window

min. 1 place for bed per person

CAN MEASURE

in a collective

- kitchen - how much more energy per person, if add one more person to a collective kitchen, vs building one more kitchen

in personal spaces

- temeperature, energy use
- time spent there

- if people adjust when they see how much energy they use, also how they act in comparing with others



+40.59

+40.80

+40.90

+40.28

22 PLATSER

32 PLATSER

+41.25

+41.40

+41.59

+41.70

+41.80

+41.90+

+43.60

ENTRÉTORGET

UP

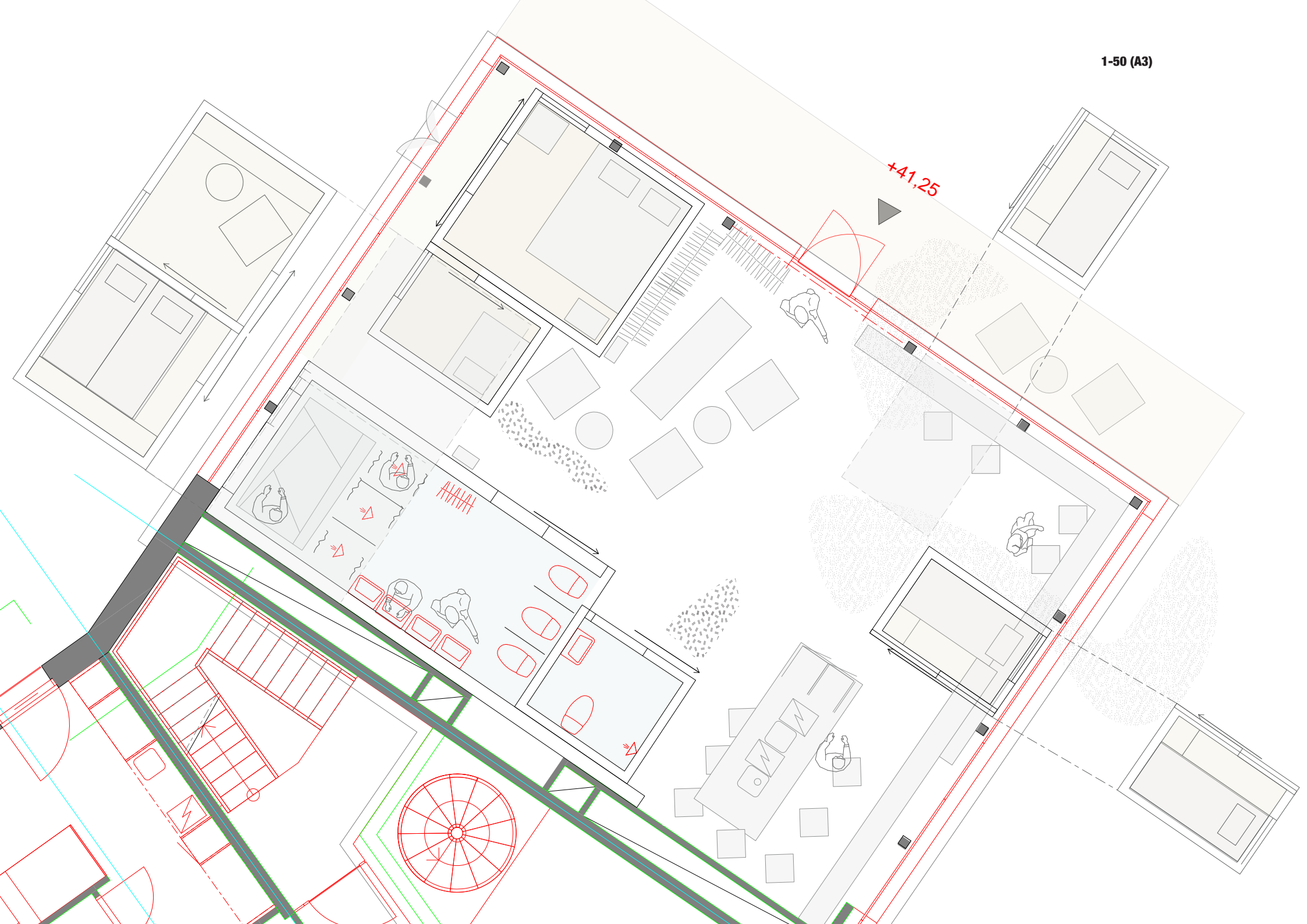

Barbara Gensler

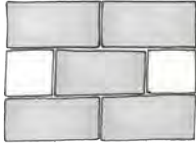
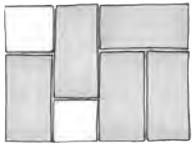
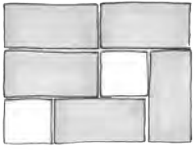
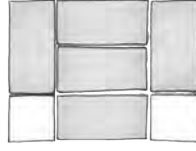
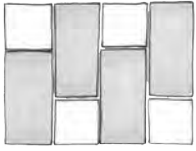
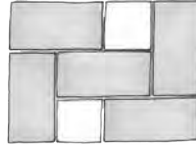
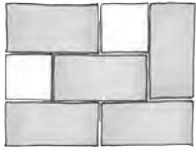
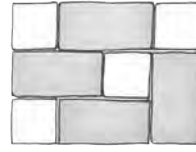
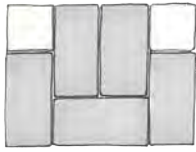

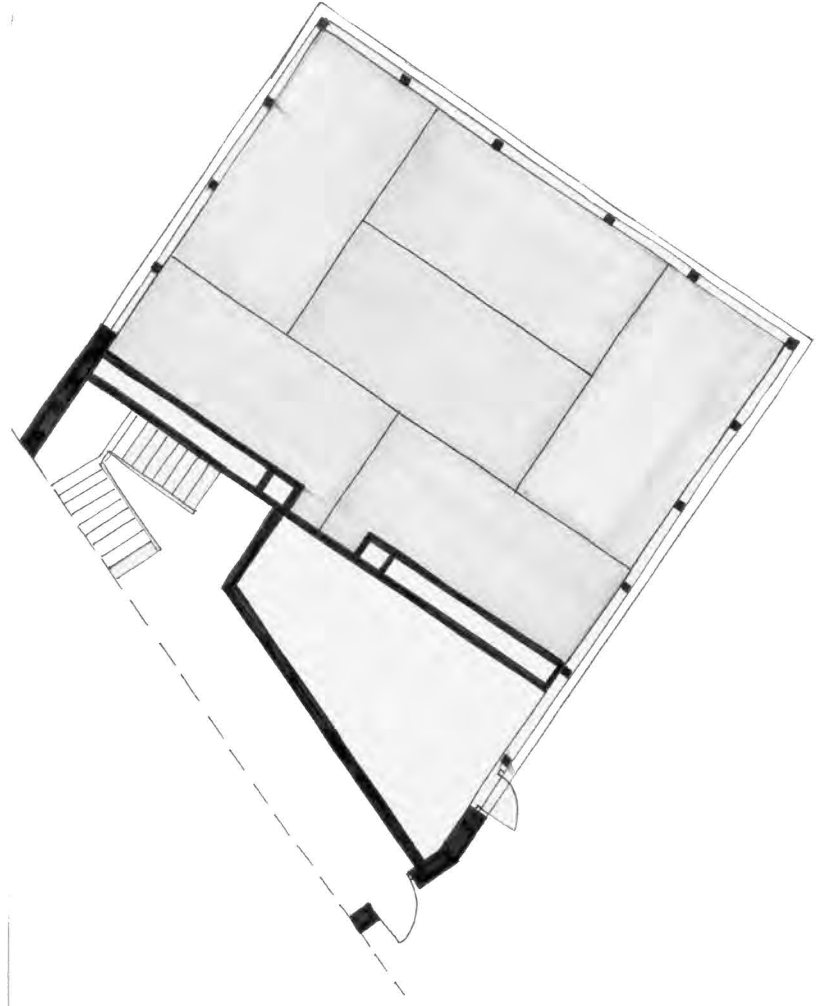

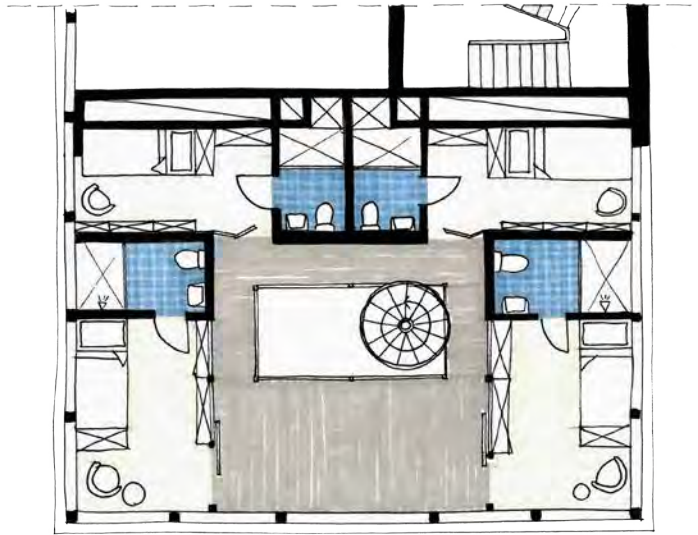
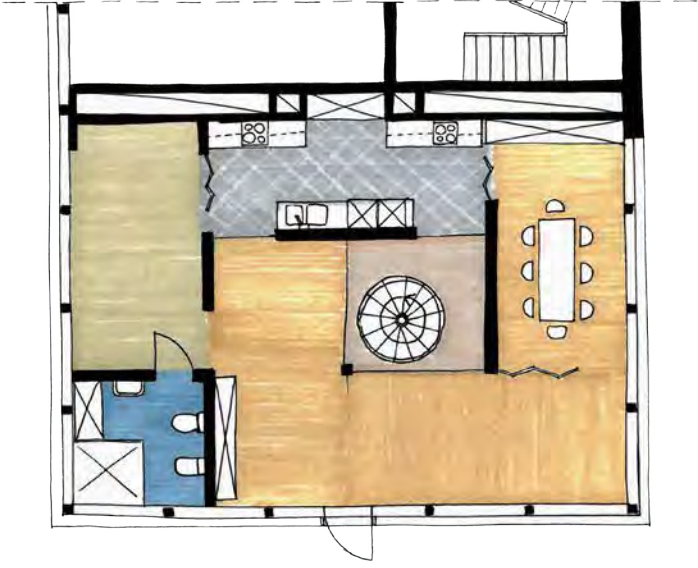

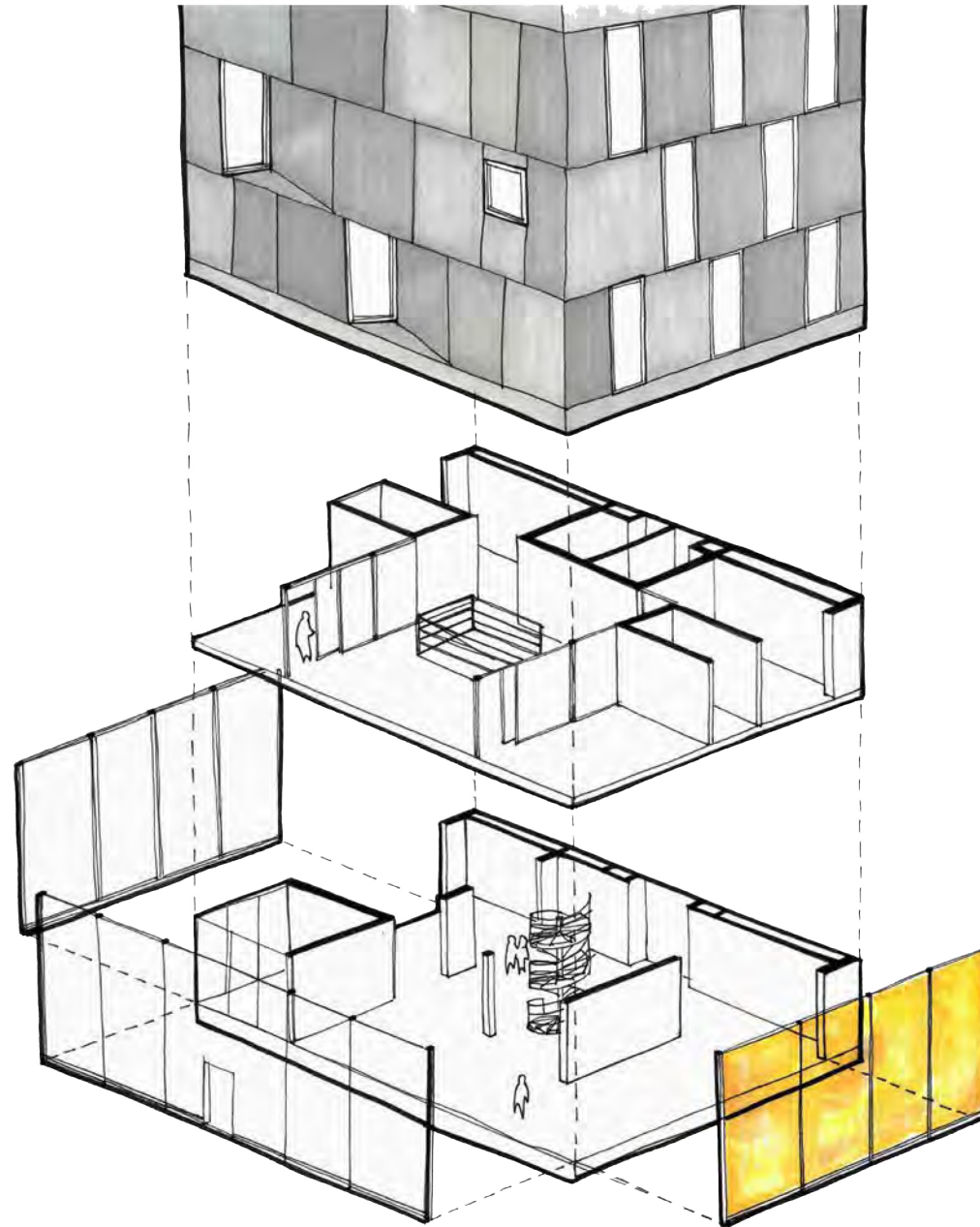

VISUALISATION



Axel Jogefalk

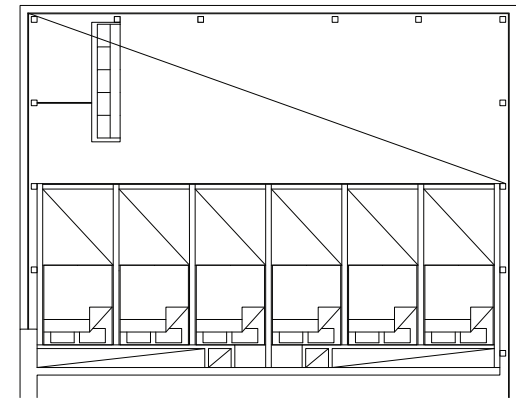
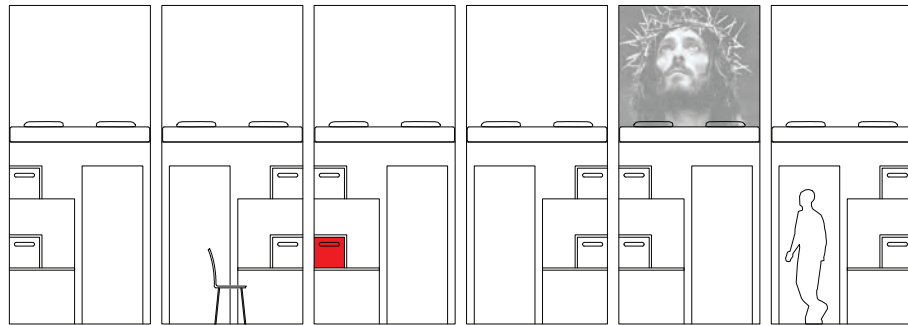
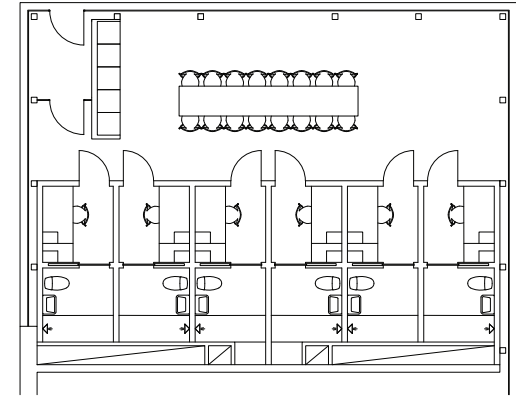
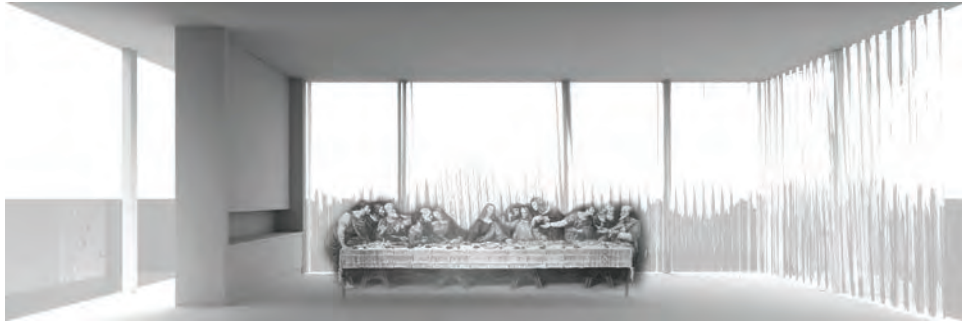

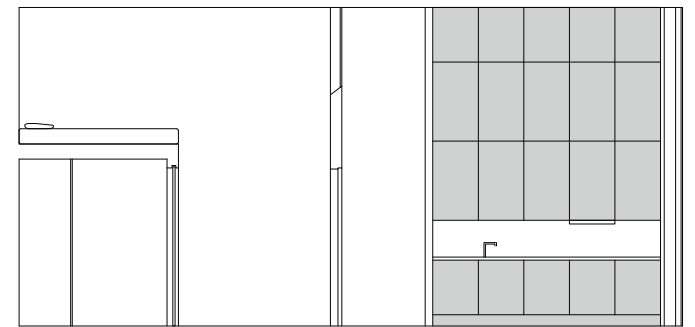
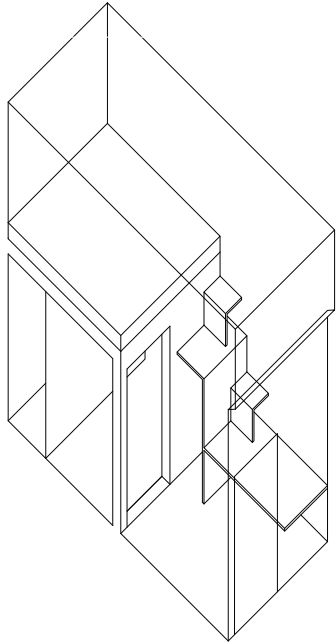
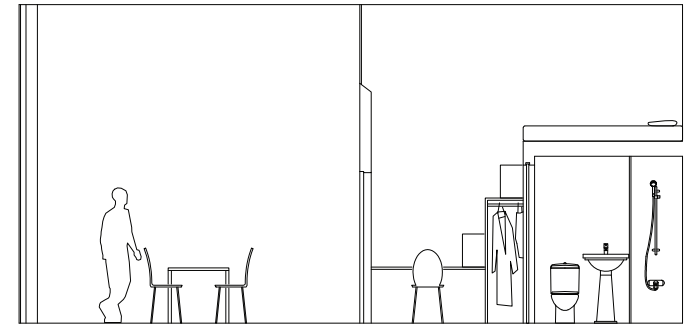
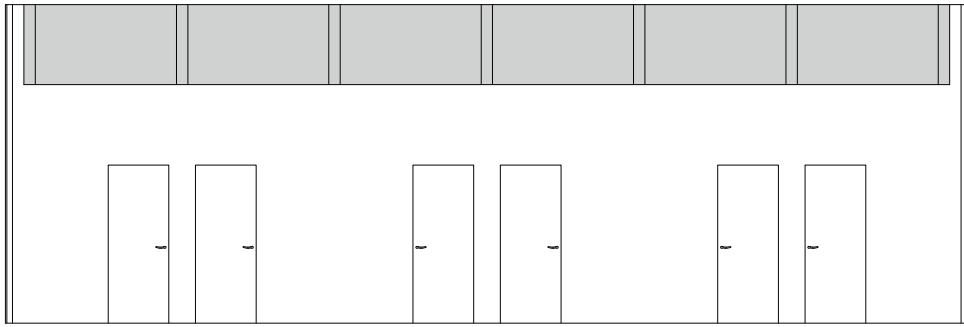

Federico Sforzi



FEDERICO SFORZI



THE STUDENT



MONEY

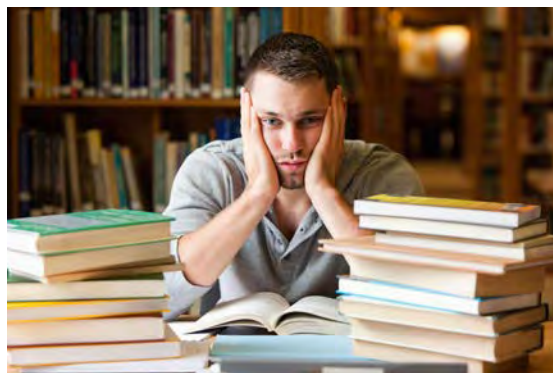

STUDY

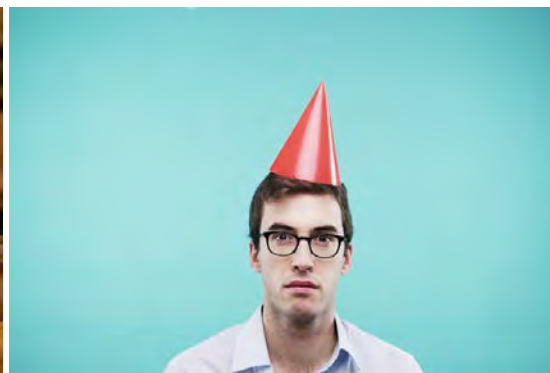

SOCIAL LIFE



FITNESS



THE CONSTRUCTION COMPANY

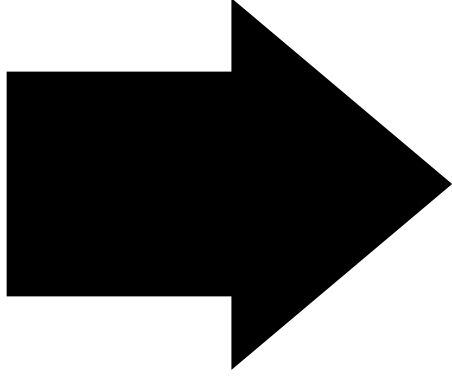
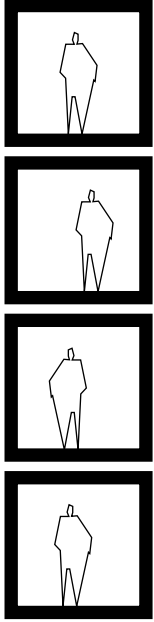

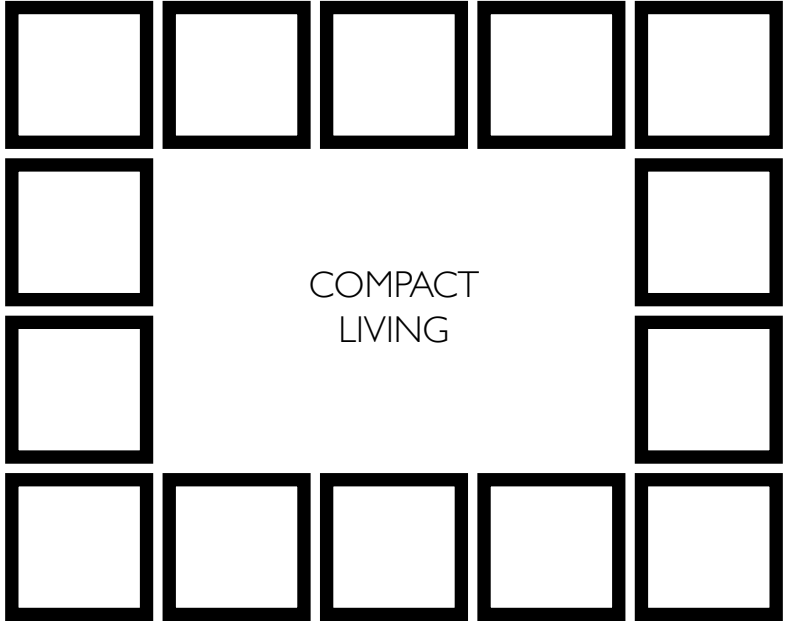

COMPACT
LIVING

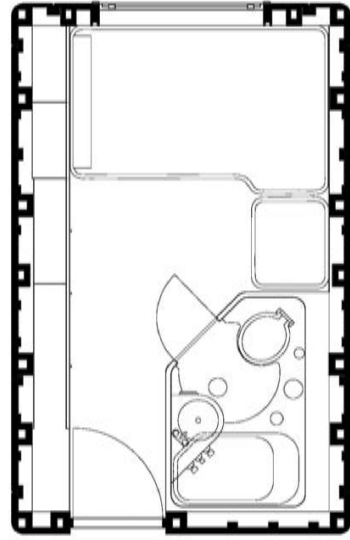
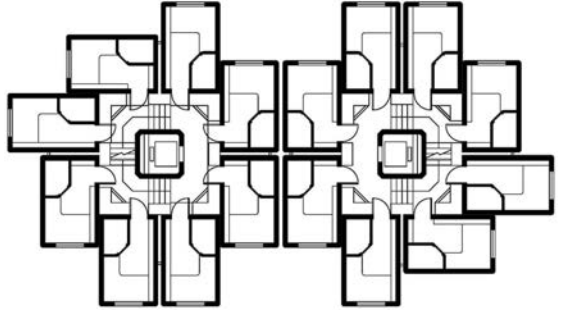

NAKAGIN CAPSULE TOWER
Arch. Kisho Kurokawa



How much space does a student need?

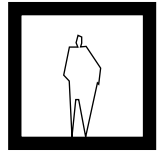

COMMON
SPACE

LIVING

TRAINING

SECTION

Scale 1:100

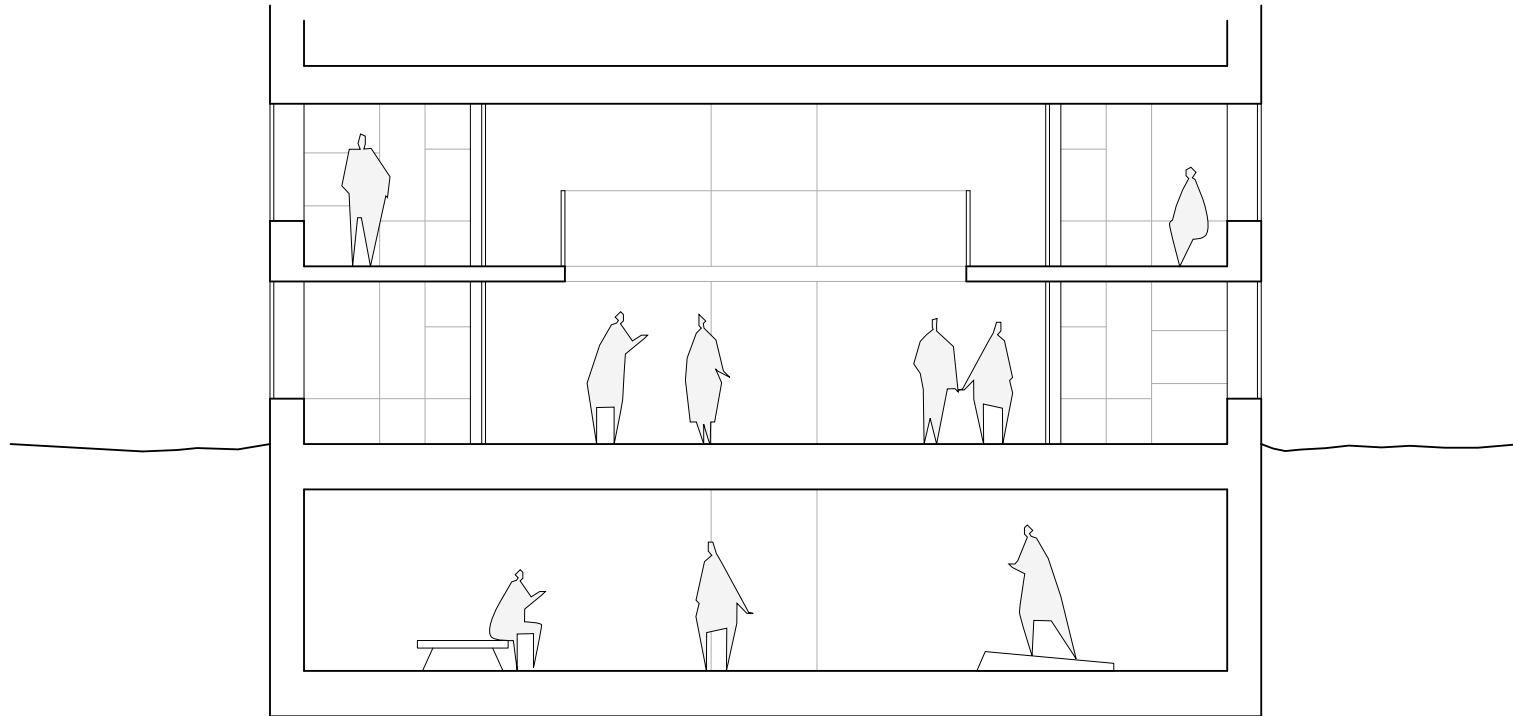

0 1 2 5

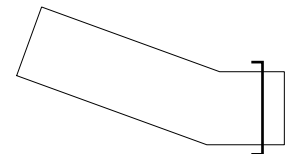

GROUND FLOOR

Scale 1:100

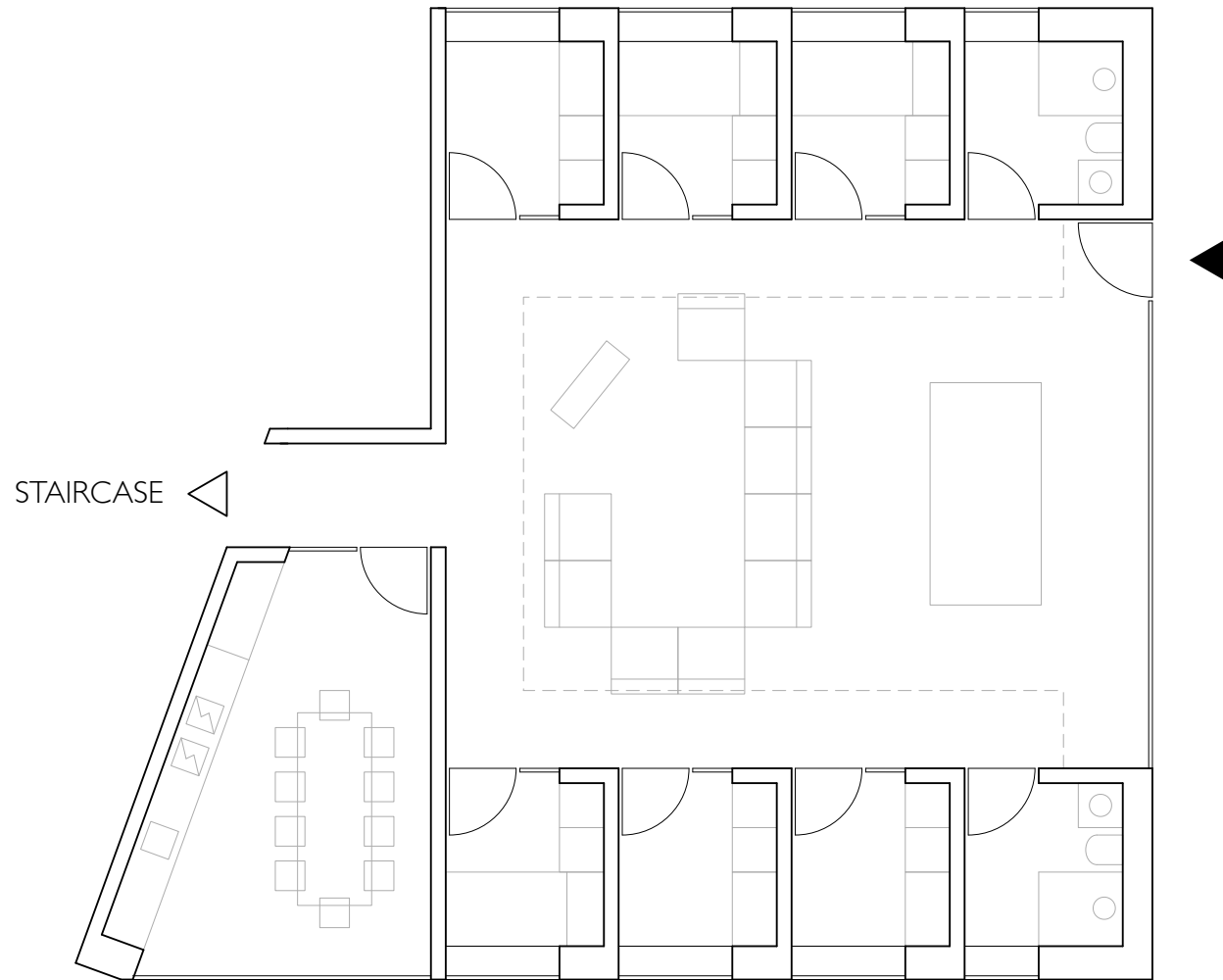

FIRST FLOOR

Scale 1:100

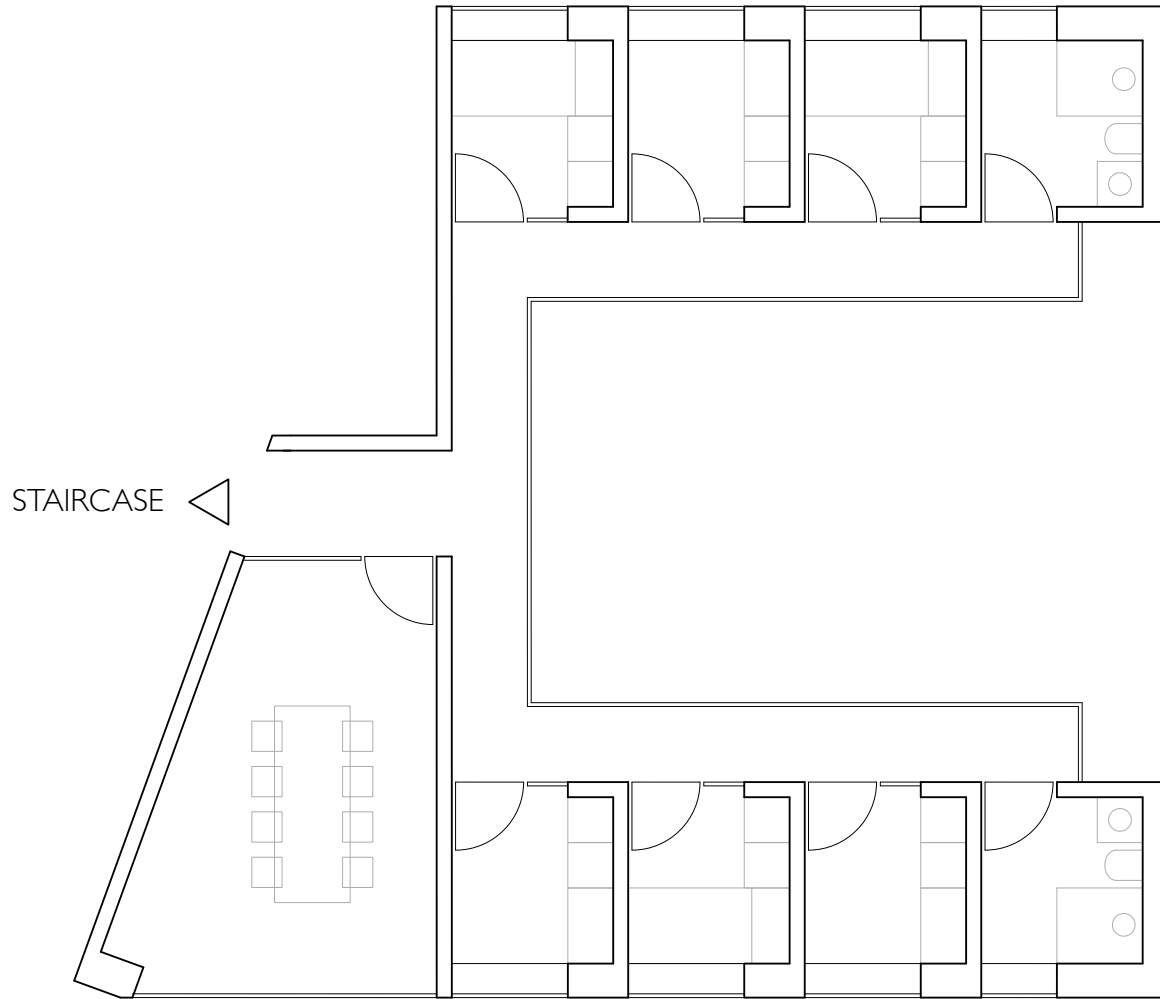

THE ROOM

Scale 1:50

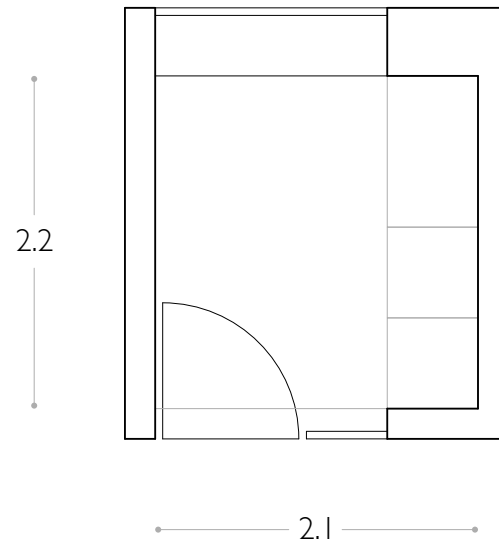

CLOSE
10 a.m.

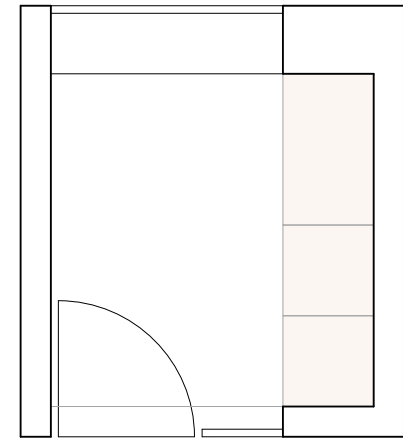
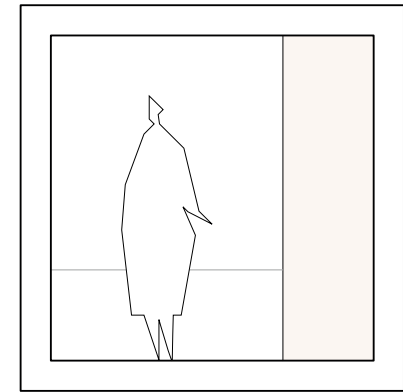
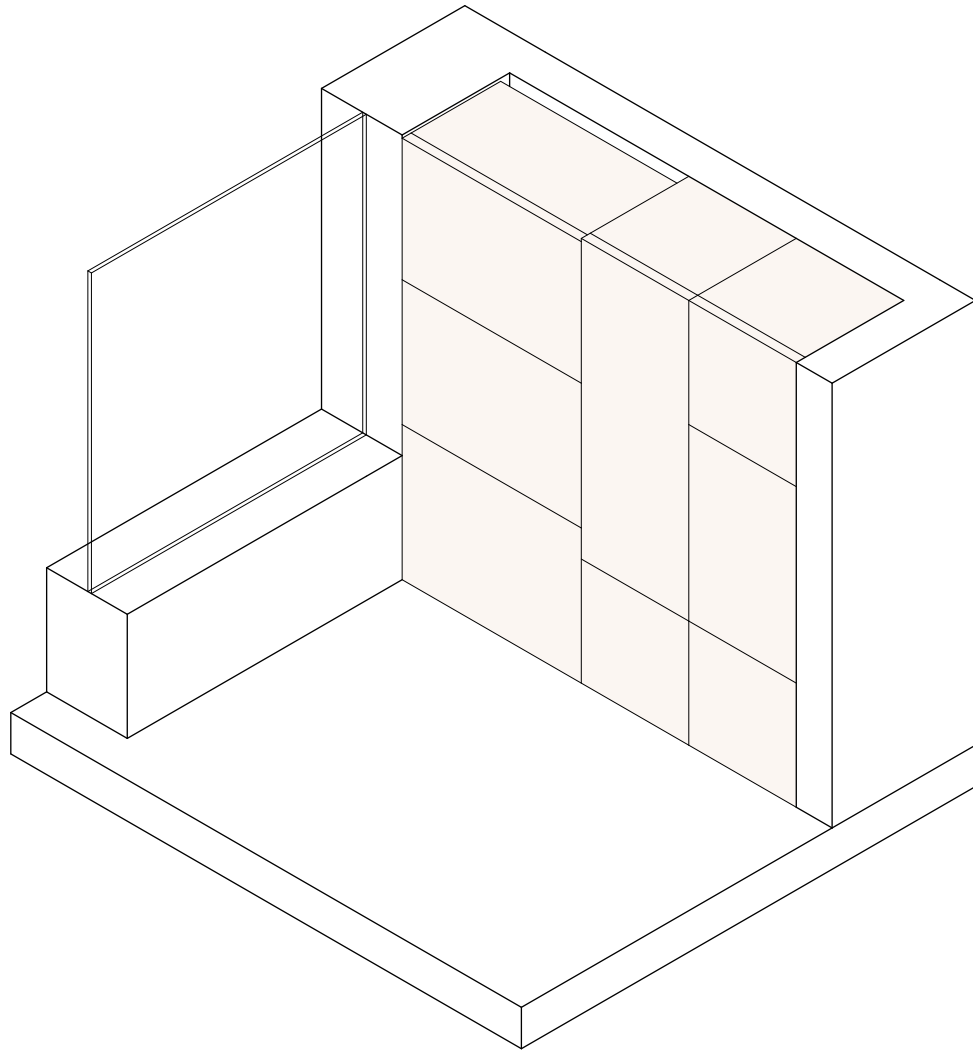

STUDY

4 p.m.

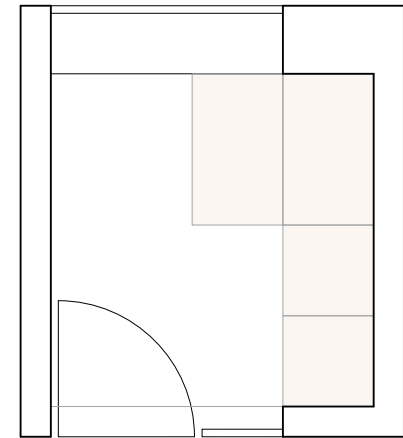
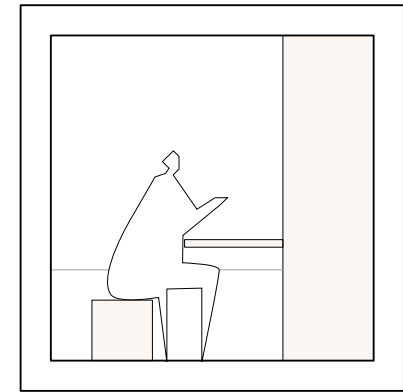
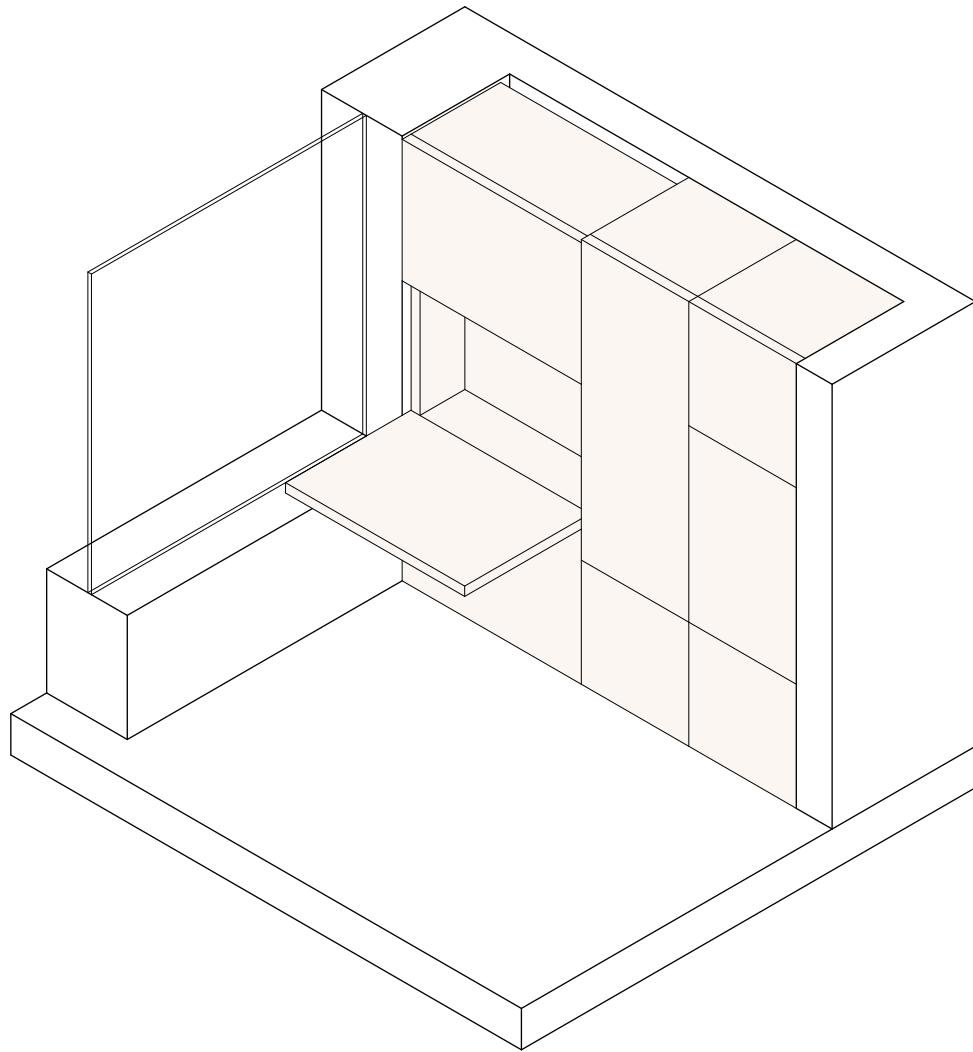

SLEEP

1 a.m.

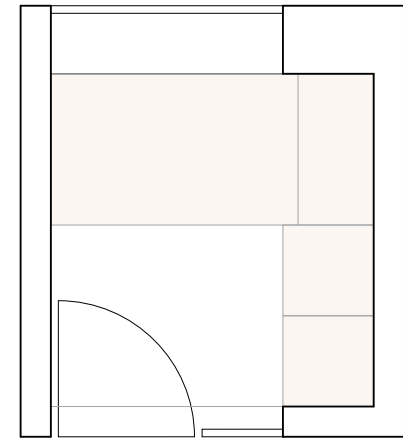
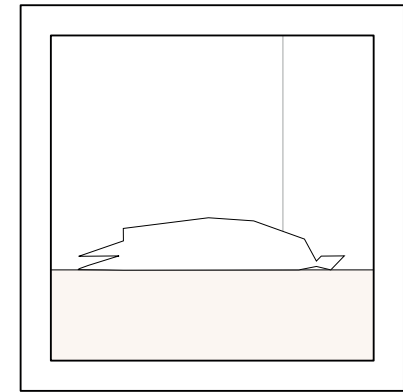
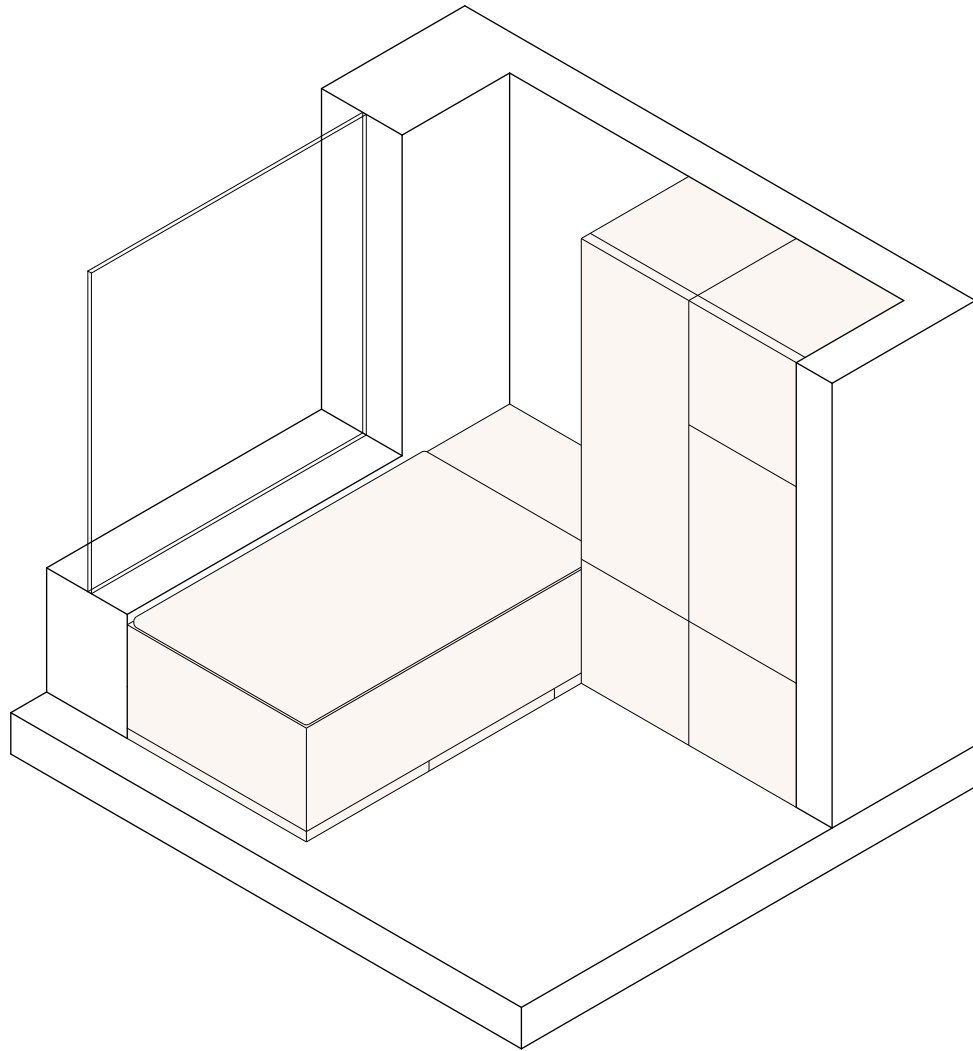

Marlene Gratzner

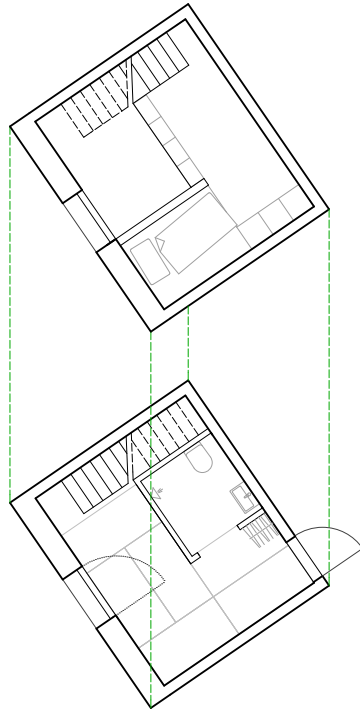

ROOM
M 1:100

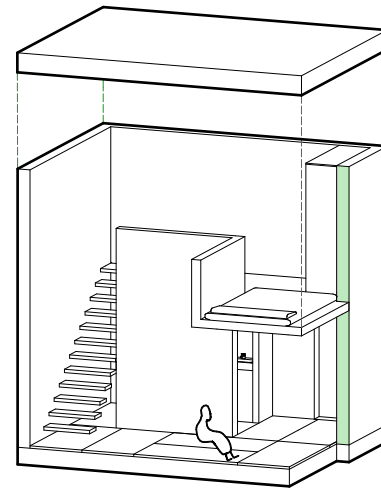

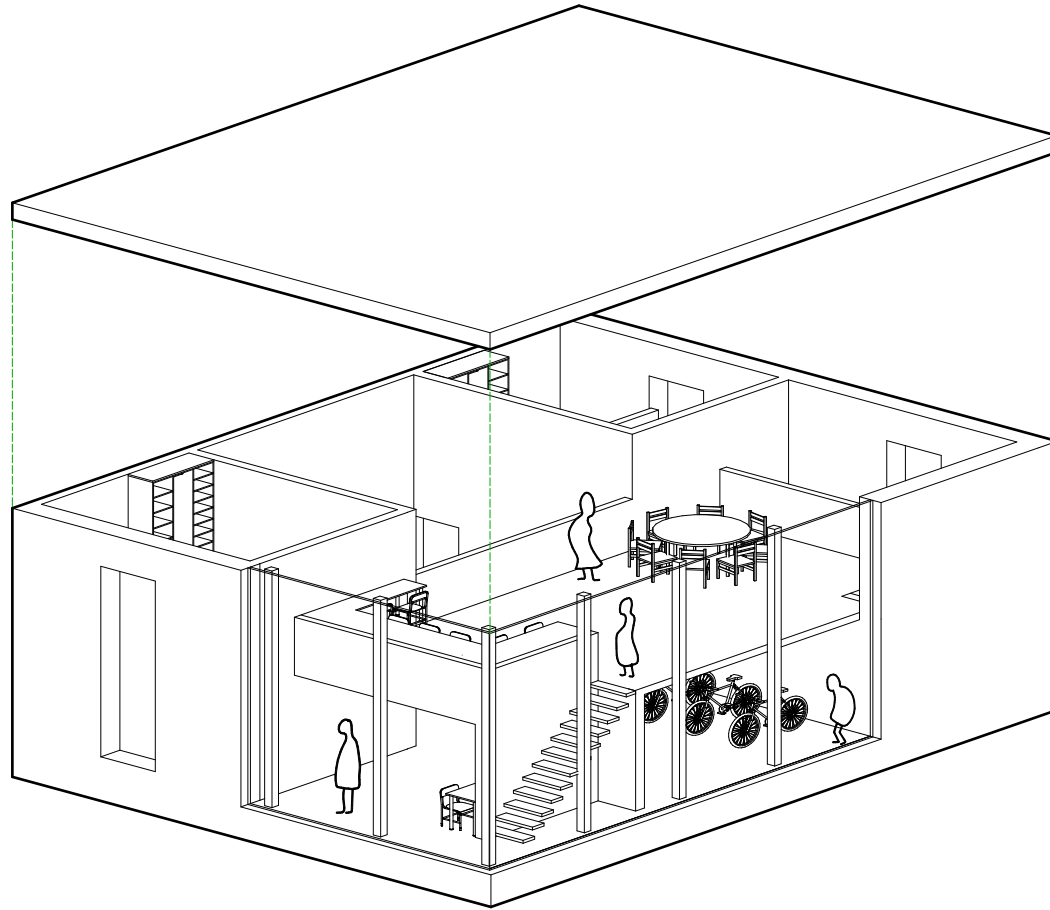

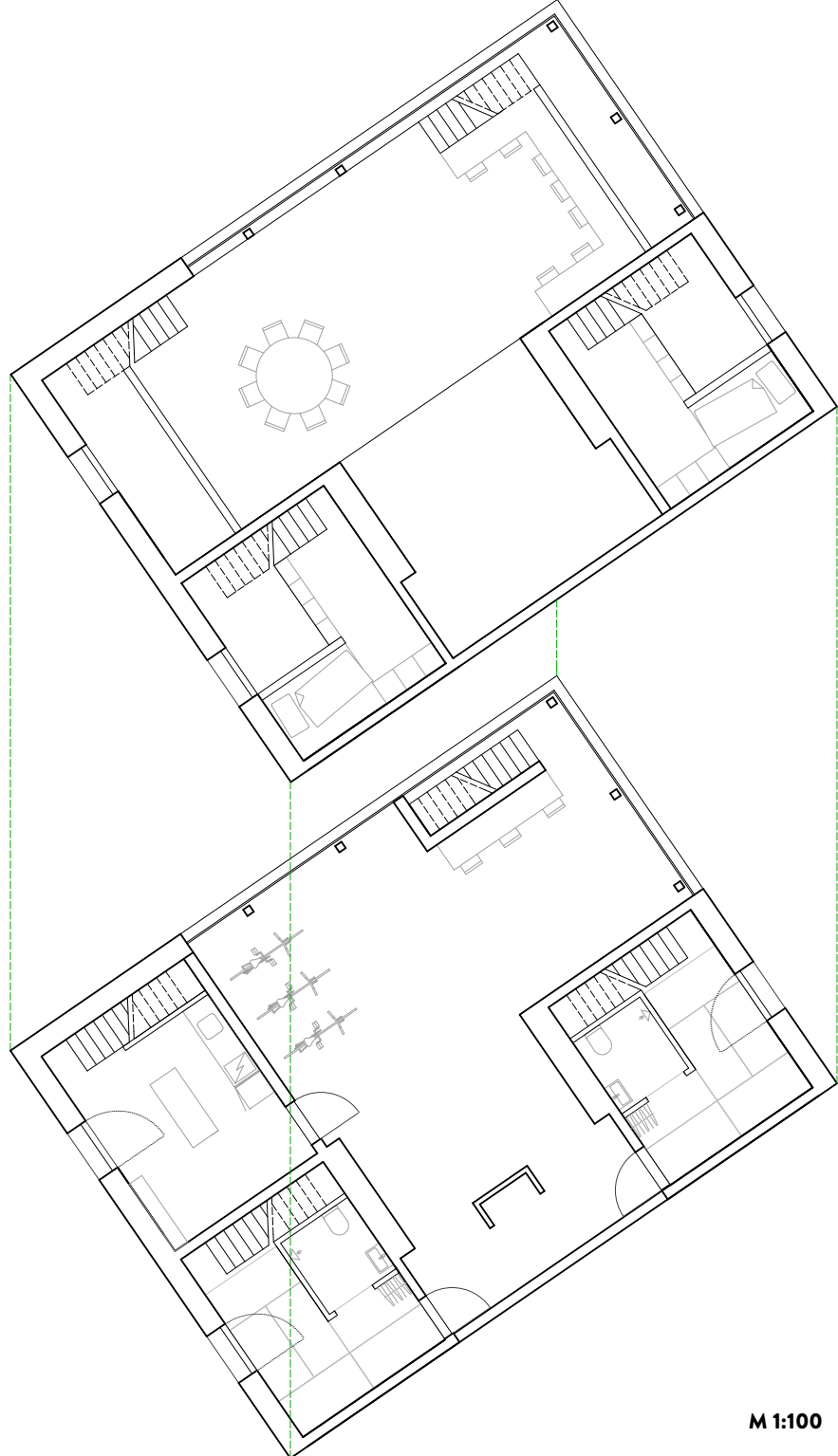

MARLENE GRATZER
STUDIO #4

M 1:100

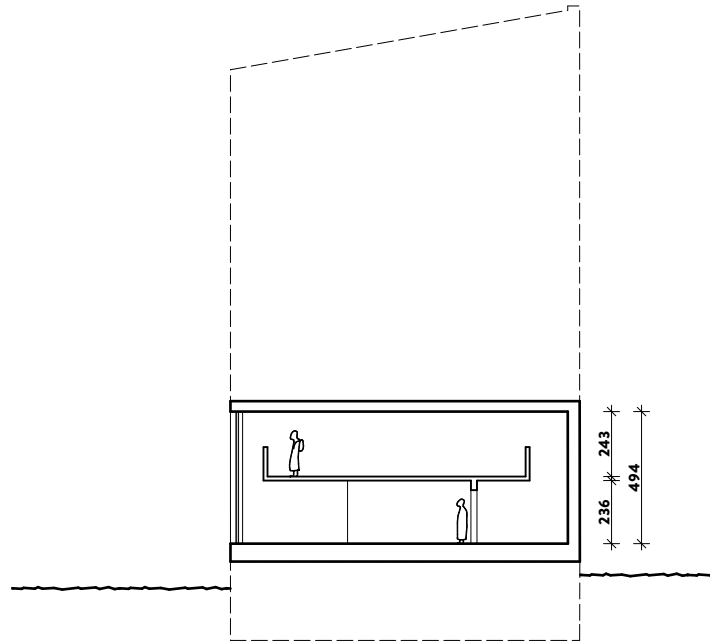

**SECTION
M 1:200**



EXERCISE FOR ENERGY

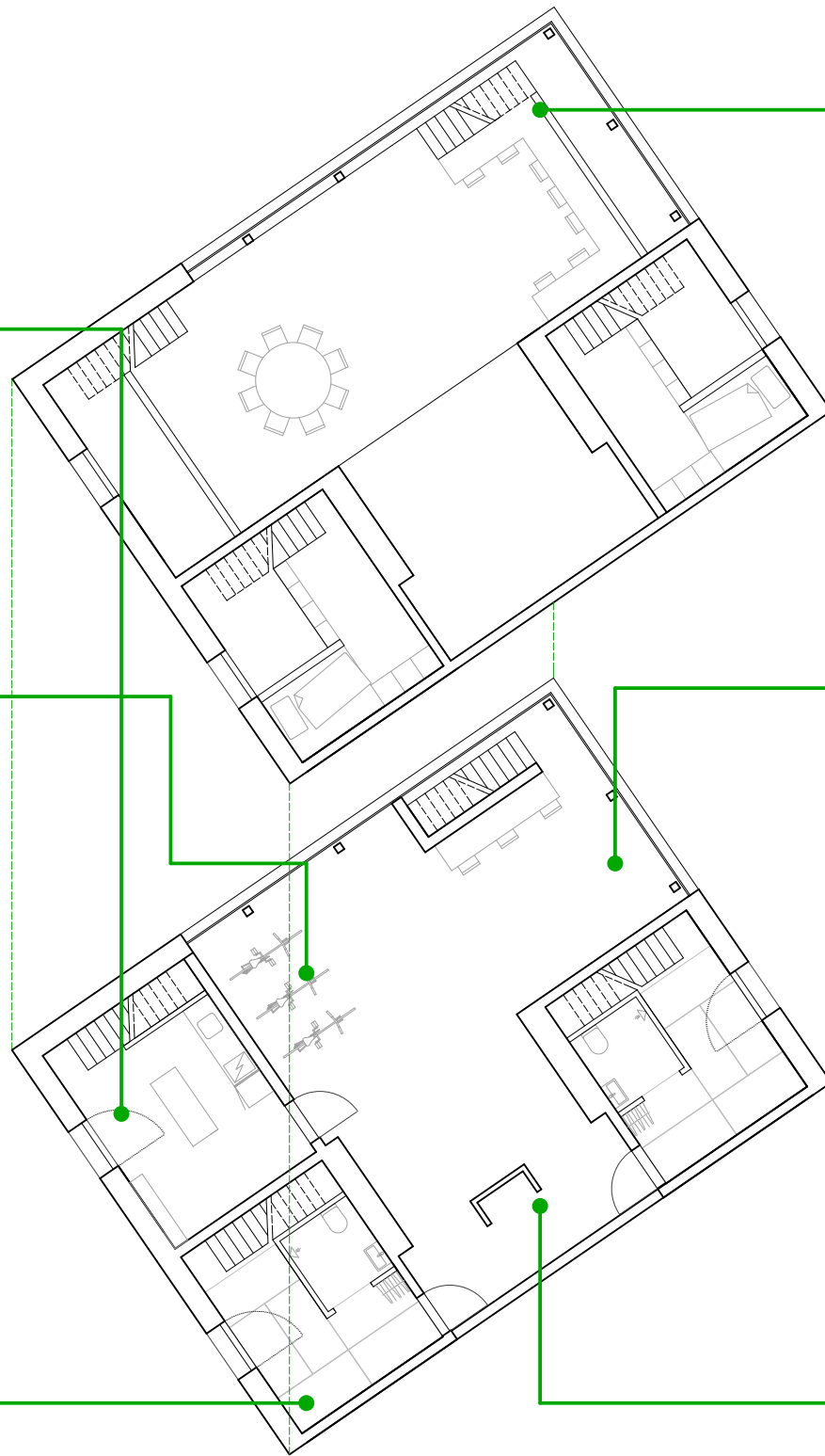

Arthur Salonen

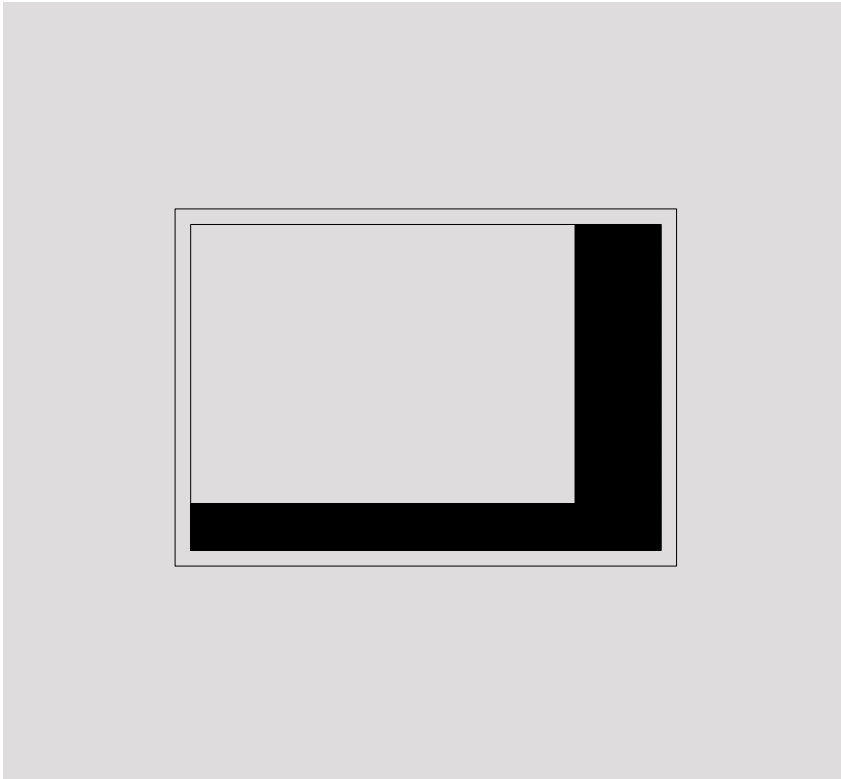

Conceptual Diagram

Light, Space & Ease Of Use.

Studenthousing on KTH Campus
Osquildas Väg

Arthur Salonen
VT 2016 Studio 4

Light, space & use

An average person spends 90% of his/her life indoors.

(Student) Housing is a question of social relevance; and in a small apartment, every sqm. counts.

I started the process in trying to find a innovative concept, but I found it very hard to make innovation for innovations sake, innovation should be born out of necessity, so I analysed what the main problem was.

A clear problem I identified is that the Swedish building regulations create proportionally too big toilets for small apt.

And also the size of the bed requires too much space, these only make the apt. feel smaller.

So its a question of space; how you organise it, & how you use it.

I lay the hypothesis that small and cramped apartments do not benefit the well-being of their dwellers.

The Design should not be the painting, it should only be a blank canvas offering a frame for life.

The idea is that the architect does

a good work for the people who live in it by providing a well articulated apartment.

Space represents freedom of possibilities.

Use

pleasure to use, pleasure to live in, like a glove that perfectly fits the hand

Light, Space

The union of space and light are orchestrated by the ceiling height of 4.2m accompanied by the big openings that makes the space shower in daylight, This helps to create a seamless interaction between

the inside and outside.

The mezzanine creates a private space for sleeping.

The corridor has been removed for optimising the floor area. Every apt. has their own entrance from the ground floor.

The bathroom is not drawn according to Swedish standards, but it can meet the regulations by an adjustable wall - so the size of the bathroom can be adjusted according to its needs.

I aimed for the typical, but it ended being something different.

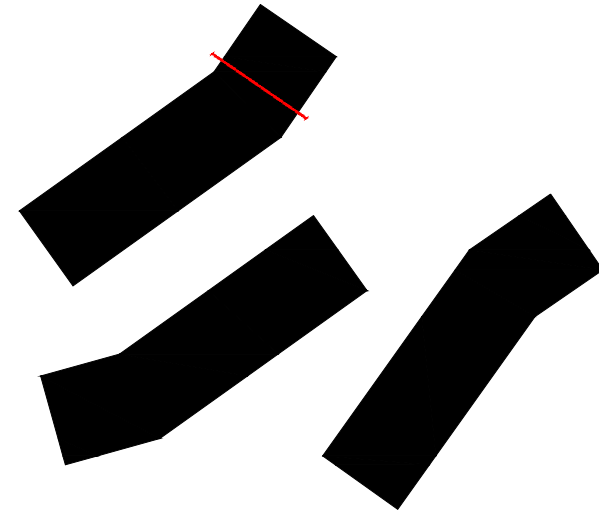

Siteplan 1:500

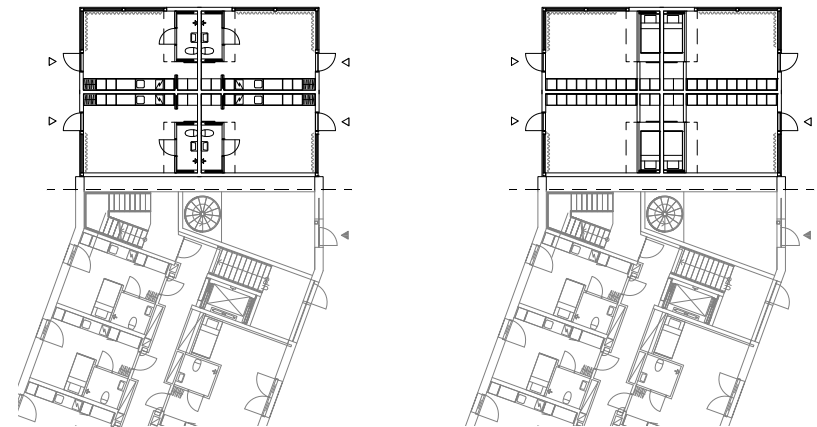

Floorplan 1:200

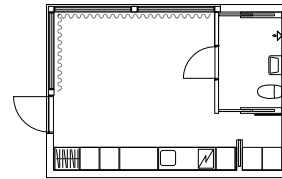
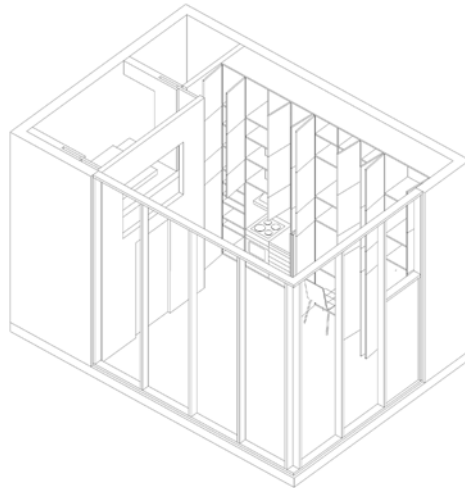
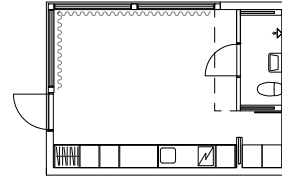
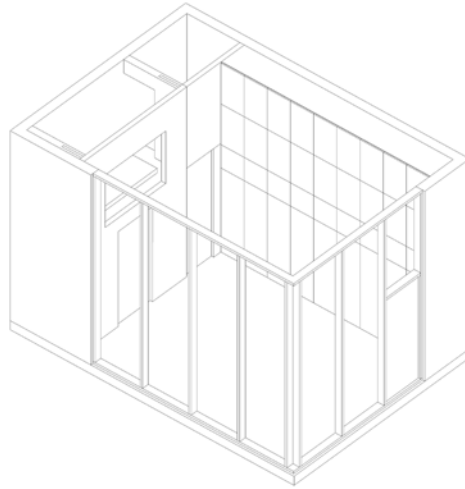

Fredrik Gärdhammar

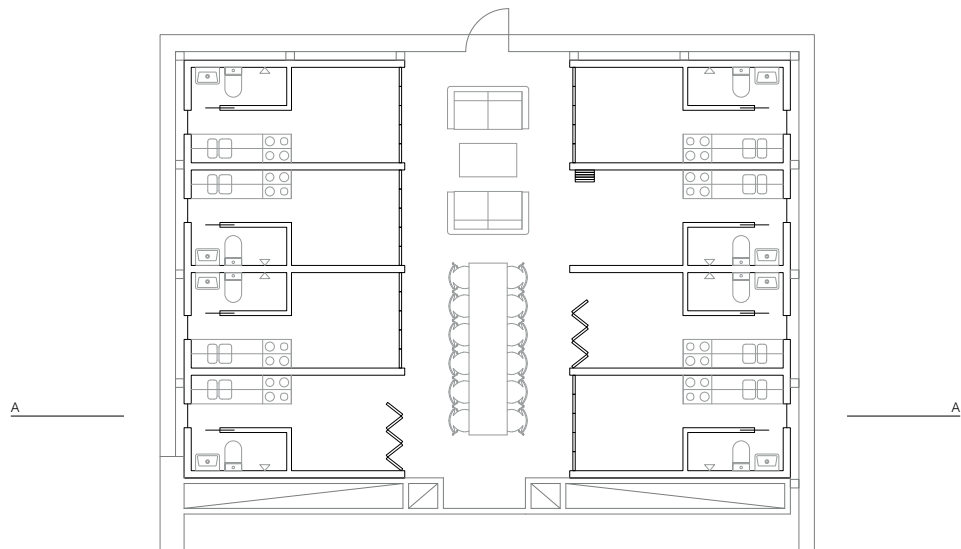

Plan 1:100

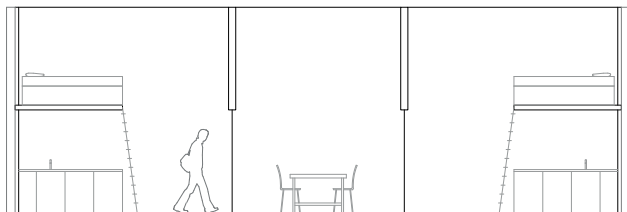
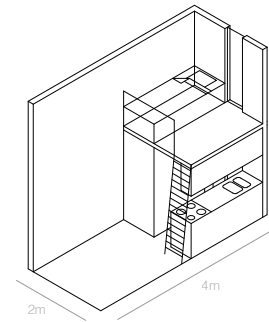

AA Sektion 1:100

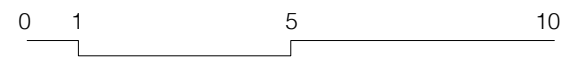

Jean Philippe Guignard

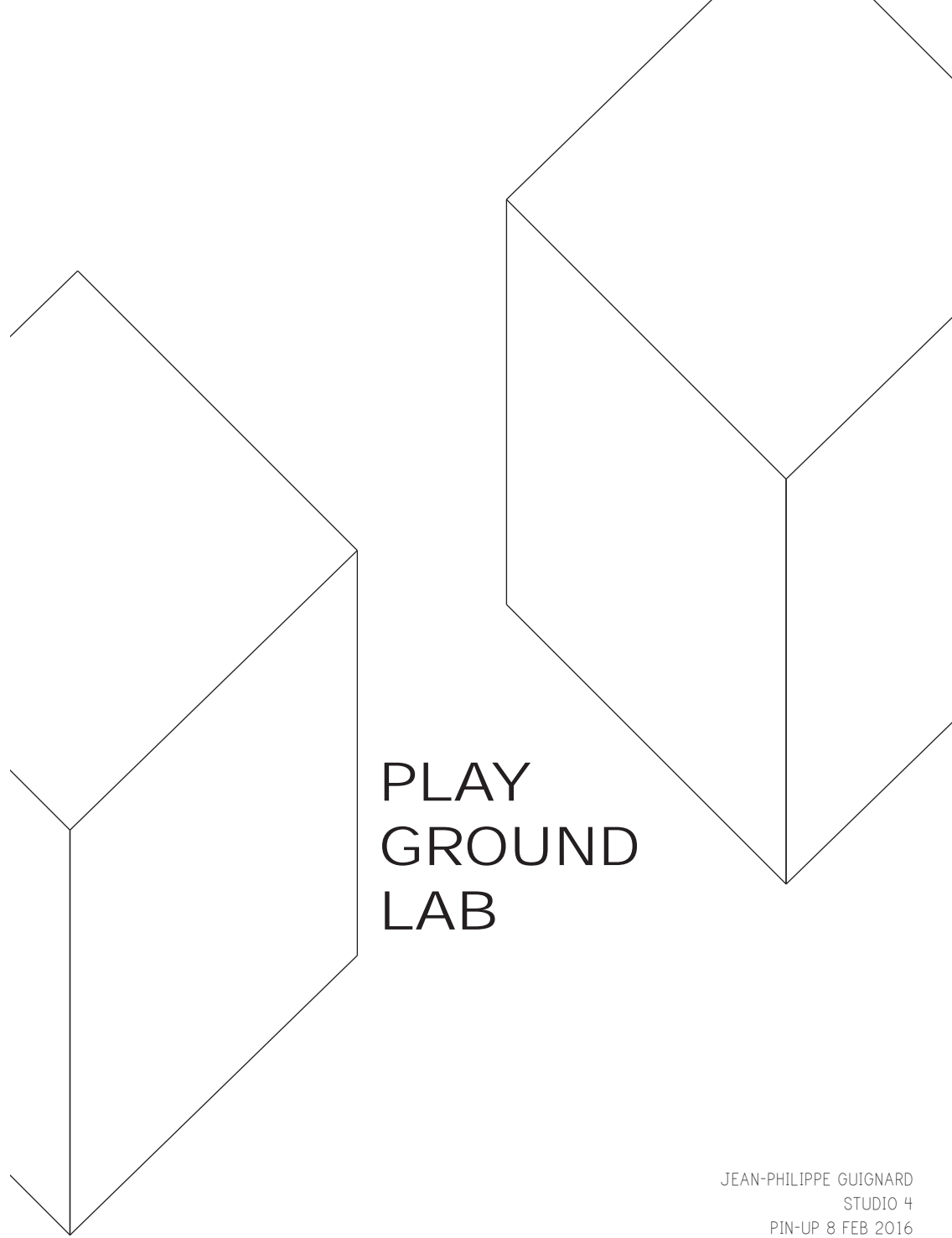

PLAY
GROUND
LAB

JEAN-PHILIPPE GUIGNARD
STUDIO 4
PIN-UP 8 FEB 2016

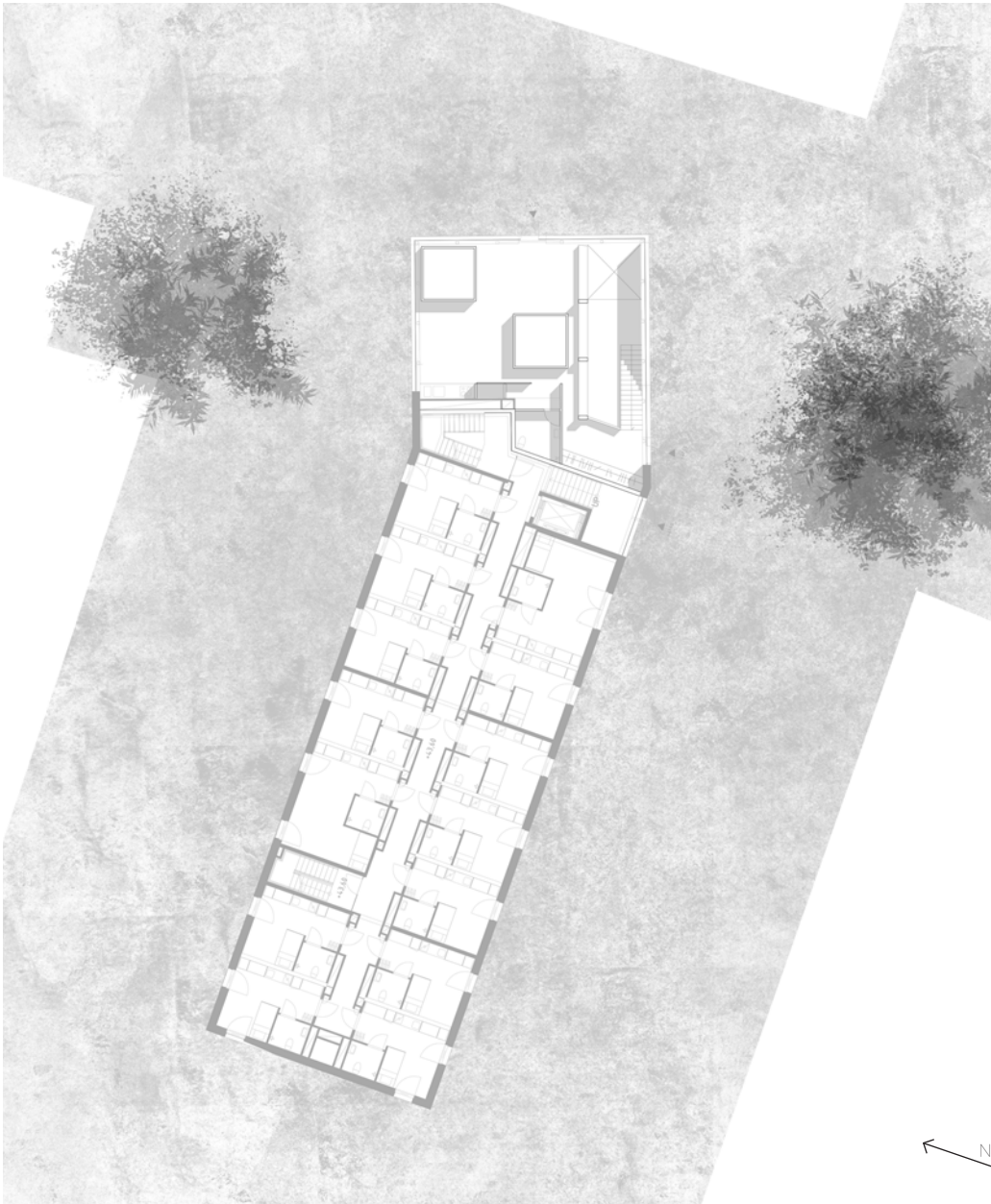

// GROUND FLOOR

SCALE 1/200

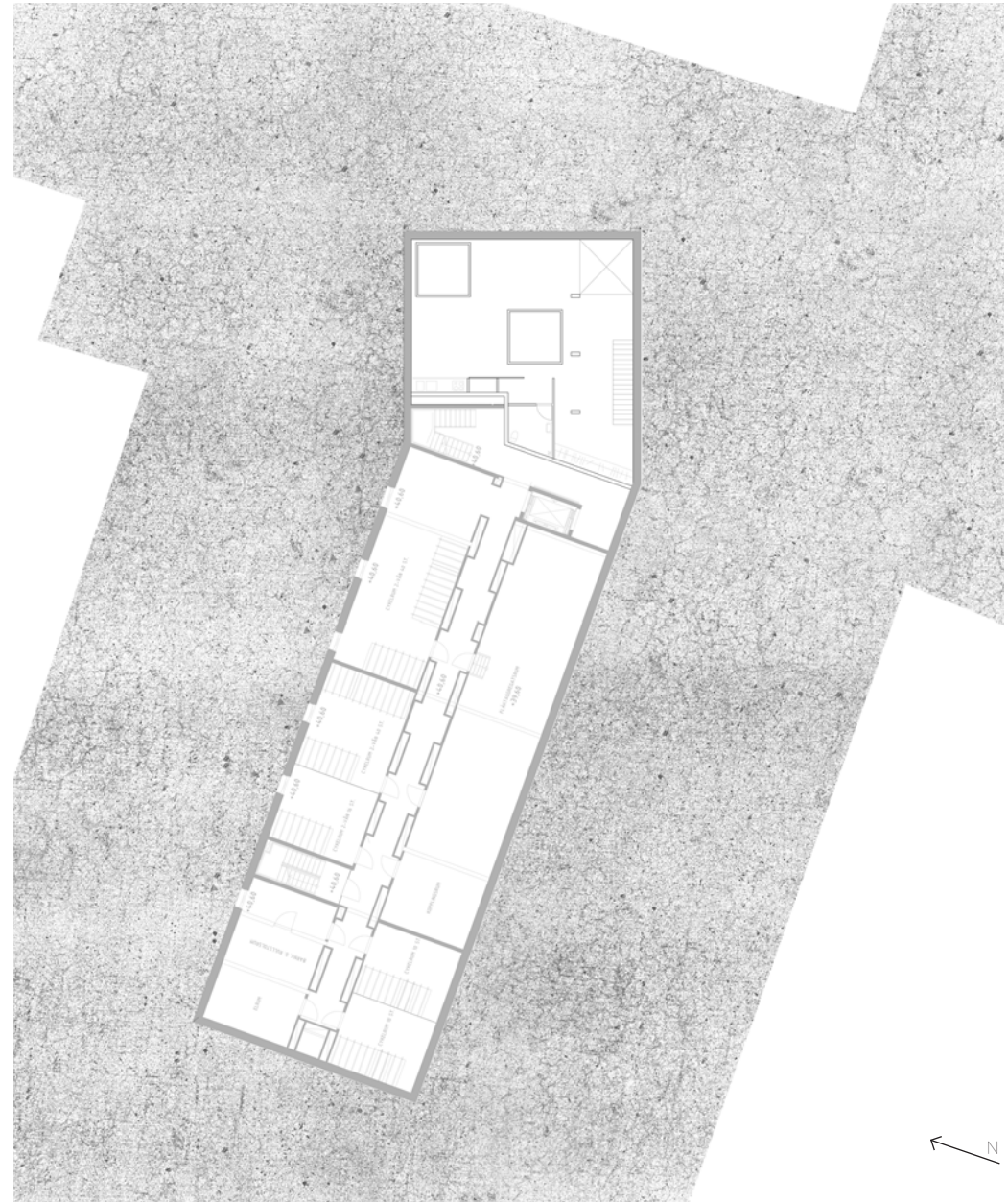

// UNDERGROUND FLOOR

SCALE 1/200

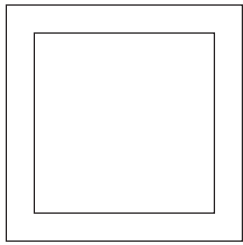

//RULE 1
USEFUL THICKNESS OF 50 CENTIMETERS.ALL AROUND

// RULE 2
MAXIMAL DIMENSION OF THE BOX:
3Mx3Mx3M
MAX AREA: 9 M2
VOLUME:27 M3

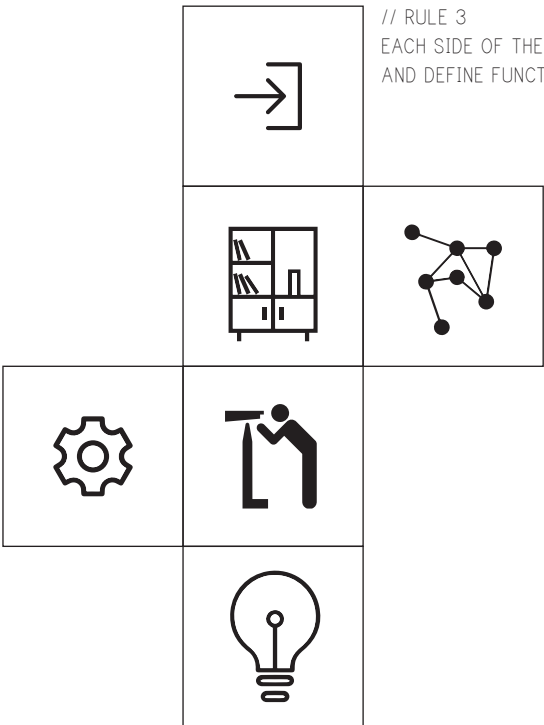
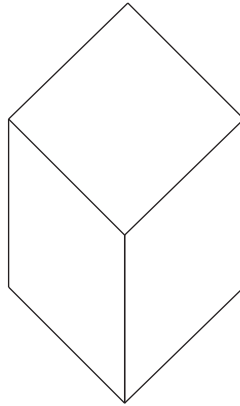

// RULE 3
EACH SIDE OF THE BOX HAVE A DIFFERENT AND DEFINE FUNCTION

- ENTRANCE
- EXTERNAL USE
- CONNEXION
- MOVEMENT
- VIEW
- LIGHT

GROUND FLOOR

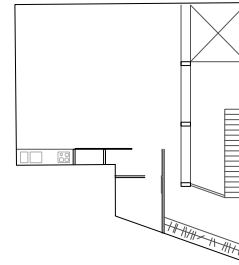

UNDERGROUND FLOOR

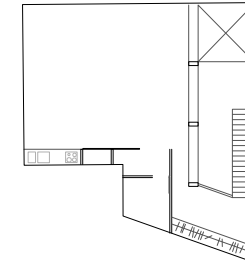

EXAMPLE OF DISPOSITION

//SCENARIO 1:
DURING THE DAY
All the boxes can be on the underground floor, the ground floor became a free space where 4 people can live. This partition is the same as a classical home (day/night)

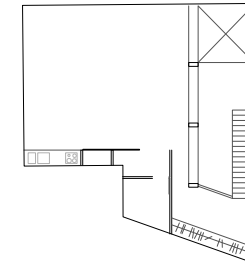
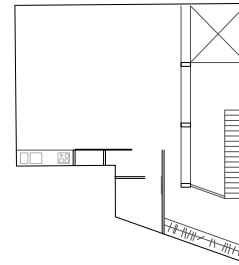

//SCENARIO 2:
AN EXHIBITION SPACE
The underground floor is totally free and host an exhibition about the work in the live in Lab. Visitors enter directly from the entrance and go directly downstairs. Public private separation.

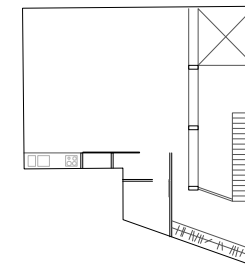
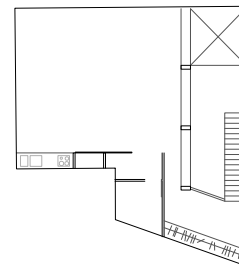

//SCENARIO 3:
A LATE DINER
Somebody is coming home late tonight and prepare a diner. All the others are sleeping and not disturbed by the noise upstairs. Here the separation between the two spaces is made by two different rythme of life

// GENERAL DESIGN RULES

// SCENARI

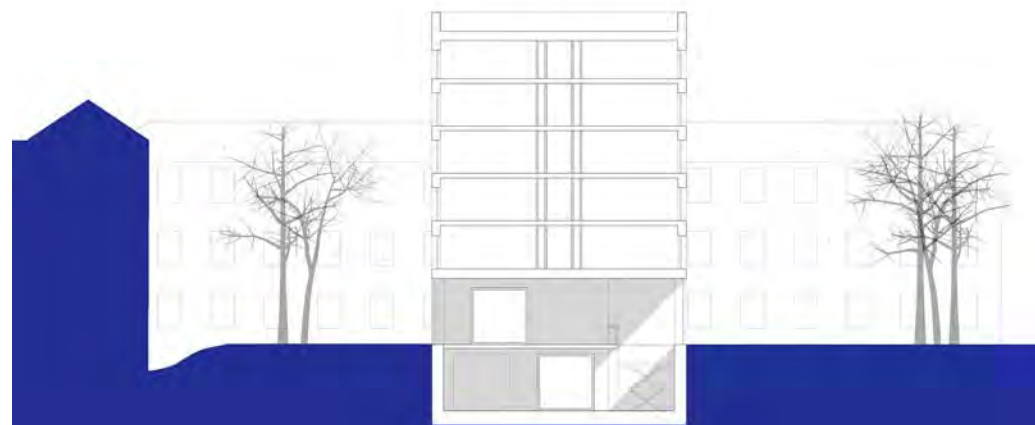

// SKETCHES & TRANSVERSAL SECTION

SCALE 1/200