

A futuristic spacecraft is shown in orbit above the Earth. The spacecraft has a prominent nose cone with black and white vertical stripes, a central white cylindrical section, and a blue section towards the rear. It features two long, thin solar panels extending from the sides. The Earth's surface is visible below, showing blue oceans and white clouds against a black background of space.

# Report for Human Spaceflight Course

Spring 2016

# Table of contents

<i>1. Introduction</i>	<i>3</i>
<i>2. Modules</i>	<i>4</i>
<i>a. Guest Module</i>	<i>4</i>
<i>b. The Infinite View Module</i>	<i>7</i>
<i>c. Crew Module</i>	<i>7</i>
<i>d. EVA Module and Expansion Node</i>	<i>12</i>
<i>e. Solar Panels</i>	<i>13</i>
<i>3. Other Aspects</i>	<i>14</i>
<i>a. Robotic Arm</i>	<i>14</i>
<i>b. Attitude Control</i>	<i>15</i>
<i>4. Mass Estimations</i>	<i>16</i>
<i>5. Conclusion</i>	<i>16</i>
<i>6. References</i>	<i>16</i>

# Vehicle Concept and Design for a Space Hotel

Kavithasan Patkunam, Thales Fragoso, Marta Bruxelles, Simon Rommelaere, Matthieu Noyon  
*KTH Royal Institute of Technology, 100 44 Stockholm, Sweden*

**The objective of this report is to provide a conceptual design for a Space hotel which can sustain itself in Space for about 20 years of lifetime. The Vehicle's exterior design, the concept and the interior design along with the customers safety and comfort will be discussed in detail.**

## I. Introduction

If you had the money, wouldn't you be fascinated to pack your bag and make a trip to Space? It would be amazing if it is possible to travel to a hotel in space and stay there. We have worked hard to produce a design for a Space Hotel which is inspired by the modular technology of the International Space Station. The Space hotel is divided into 5 different modules and they are the Guest Module (Centre/ Main Module), Crew Module, The Infinite View Module, Expansion and EVA module and the Solar Panel Module.

To give readers the pleasure of understanding the concept and to provide a feast for your eyes, We have worked hard to produce 3D images which were produced using CATIA V5 & Autodesk Maya. We have combined aesthetic design principles with Engineering design to produce this Marvellous Space Vehicle & have spent 70+ hours in rendering and iterating the design for maximum efficiency, reliability, Safety, comfort and Smart architecture.

The Engineers to design the future, present you the 'Sky Palace'.

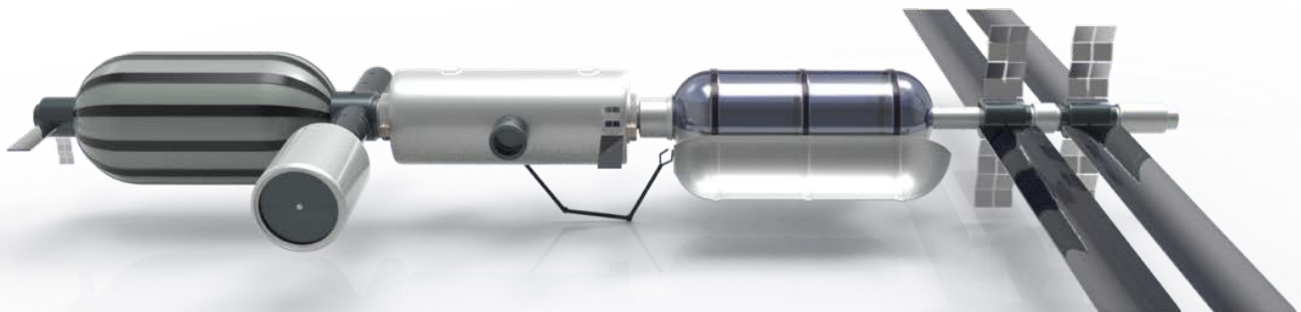

Fig.1 Sky Palace



## II. Modules

### A. Guest Module (Centre Module)

#### 1. Main reflection:

“The guest module, which is the centre part of the hotel, has to be as comfortable as a real hotel“

The reflection on how the guests will be welcomed began with this statement. The guests have to feel at ease in an environment that is basically uncomfortable.

First, in space like everywhere else, comfort means a spacious living place. But in space thanks to weightlessness, the living place is measured in volume instead of area. So we wanted a big enough volume for our guests.

As the Infinite View module, which will be described further in this report, is the living room and kitchen which will be shared by the guests, we needed a solution for their private apartment : the rooms. As sleeping in space is not an easy experience, we also wanted the guests to feel very safe in their rooms. This is the reason we decided to use the inflatable module for crew rooms and not for guest’s rooms. It could have been easy to find more space in the bigelow BA330, but with this technology we were afraid that the guests could be reluctant to sleep in it. Moreover, the inflatable module doesn’t have windows on its rooms, which would be a shame for the guest.

To have rooms as spacious as possible in the module, we then decided to use the biggest size allowed by the launcher<sup>[1]</sup> for the guest module. This means we have external dimensions of 11m long with 4,5m diameter (reduced on the edges) with the Falcon Heavy capacity. Moreover, the wall’s thickness varies between 30 and 50 cm as it is in the ISS.

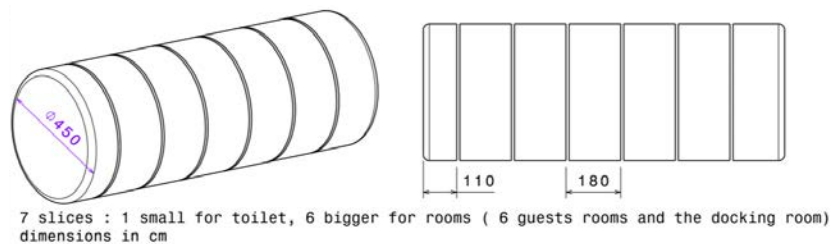

Fig.3 Guest/ Centre Module Layout

After lots of reflexions, the solution we found was to cut this module into several “slices”. Each slice is a room; this means that each room is expanded through the full diameter of the module. We also had to add a corridor, in order for the guests to pass by and go from their room to the other modules on the left and right sides. This corridor is placed on one side of the module, so that the rooms still take more than half of the module. The final design will be shown at the end of this section, with the details of the room itself.

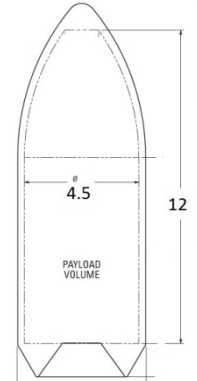

Fig.2 Launcher

The guest module is also the one on which the Dragon capsules will be docked. Two of them are docked on the hotel when the guests are inside in order to be able to evacuate every person inboard in case of emergency. One of the “slices” of the module is then a docking room, with the 2 docking sites facing on the other.

Finally one slice, smaller than the other and at the edge of the module, is a toilet room. We thought it was important to have a “guest toilet” in this module, plus another one in the crew module for the crew but that can also be used by the guests.

## 2. Design Solutions:

After this main reflexion on what the module will look like, we had different issues that needed to be solved in order to have a realistic solution.

The first issue we had was for the assembly of the hotel. The main module is the first one that will be sent into space and will be operating the assembly with the other modules and component thanks to the robotic arm. The solution of the robotic arm is discussed further in this report. This arm will be sent with the main module and will help to operate the dockings with the 2 other modules and will be used to add the components, for example deploying the solar arrays. The assembly will be unmanned and controled from the ground. For this assembly, the main module needs 2 things. The first is thrusters, in order to get to the incoming module or component and grab it with the arm. These thrusters are also used for attitude control of the overall hotel, when the wheels are saturated. There are a total of 12 thrusters, located on both edges of the module. The second thing needed is some solar panels: as the module arrives before the solar array, it needs to self-sustain its energy at the beginning. We decided to add 2 small solar panels on the sides of the module used during the assembly phase. Later, these solar panels are retracted and can be used for emergency situation in case of problems with the main solar arrays.

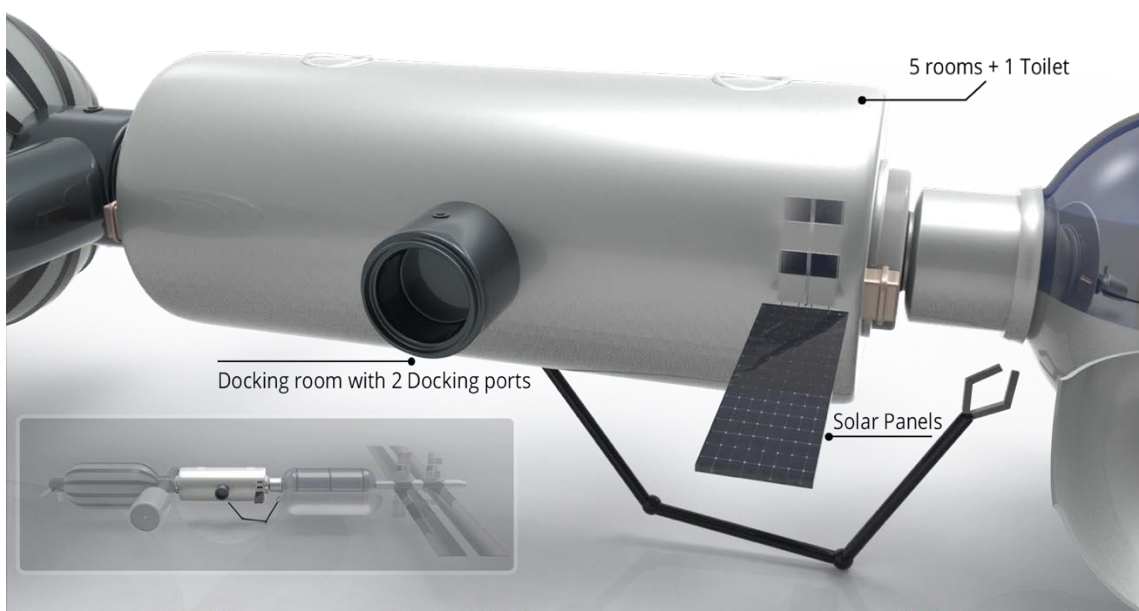

Fig.4 Design of Guest/Centre Module

As mentioned previously, the guest room is equipped with a big window to give to the guest an incredible view before going to bed. But in order to have the best view possible we had to choose what the window will be facing. For example, it was impossible to put the Dragons docked in the fields of vision of the windows. This is why we decided that the windows are facing the Earth horizon (the Infinite View module is already facing the Earth ground) and the 2 docking sites are on the Z axis, one facing the ground, the other facing the sky. Moreover, the windows are equipped with shutters that can be closed during sleeping time by guest as well as artificial light (as the entire hotel) to reproduced daily time light.

Finally we also had to find a place in the module for all technical material needed in the module, for instance the electric cables, the thermal control system or the pipes. These components cross the module from one edge to the other, so we decided to locate them in the corridor. As shown in the picture further, the lower corner of the corridor is not accessible; this is where the main part of the thermal control system and the cables and pipes are placed. Of courses, other cables or devices can also be added in the walls, both in the rooms and in the corridor, in order to make the module fully equipped.

About the docking room, we also had to choose where it is located among the 5 other guest's rooms. As it will be discuss later, an EVA airlock is located between the crew module and the guest module. We thought it was important to put the Dragon's dockings sites as far as possible from the EVA door, in order to avoid any collision between a guest that can loose his way during an EVA and the Dragons. But on the other side, the module is connected with the Infinite View module. As the view must be clear, the Dragons can't be in the field of vision and have to be as far as possible. This is the reason why the docking room is located in the middle of the module, with 3 rooms on the right and 2 on the left.

### 3. Interior design:

One can see on picture the final design of the guest module and the rooms. These rooms are as big as possible for the guest to feel at ease. Dividing the module in one part for rooms and the other for corridor allows us to have comfortable rooms and living space.



Fig.5 Design of Guest room

The bed, which is more of a sleeping bag, can be moved upward in order to close the room's door for privacy. This also let space under the bed for storage, for the guest's luggage for instance. As one can see, there are small lights at different locations in the room and the corridor as long as handles that can be grabbed when the guest wants to move.

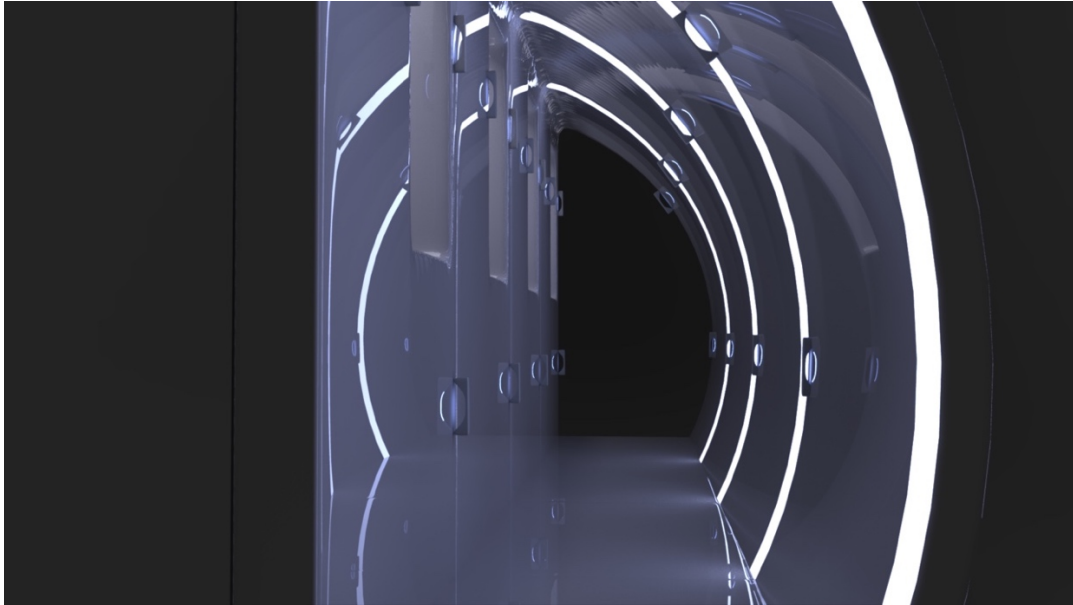

Fig.6 Design of Corridor

## **B. The Infinite View Module**

### *1. Concept:*

The main idea of this module is to present an environment in which the passenger/guests gets immersed with the experience that he/she is in space. The module features an incredible view which will please the guests and give them a feeling that their money is well spent. Also, this module serves as the primary storage facility of the Space Hotel. This module has a length of 6m and a diameter of 4.5m.

To achieve an incredible view, the top part of the module will be made up of Transparent Aluminium (ALON) Ceramic composite glass. We will use 4 layers of this material in total. 1 layer for Exterior protection against Micro Meteorites, 2 for pressurisation and 1 for redundancy. This transparent structure enables connecting the viewer to look into the Space and at the Earth with much comfort. The module will be divided into two parts, the top will be for the guest to look into the Space and Earth and the part will be for Storage. The Floor separating both the parts consists of a retractable door both, Storage cylinder openings for Food and Entertainment utilities supply and the floor is integrated with a display which can show images of space on the floor integrating both the True view of Space plus the Virtual view through the floor while experiencing weightlessness.

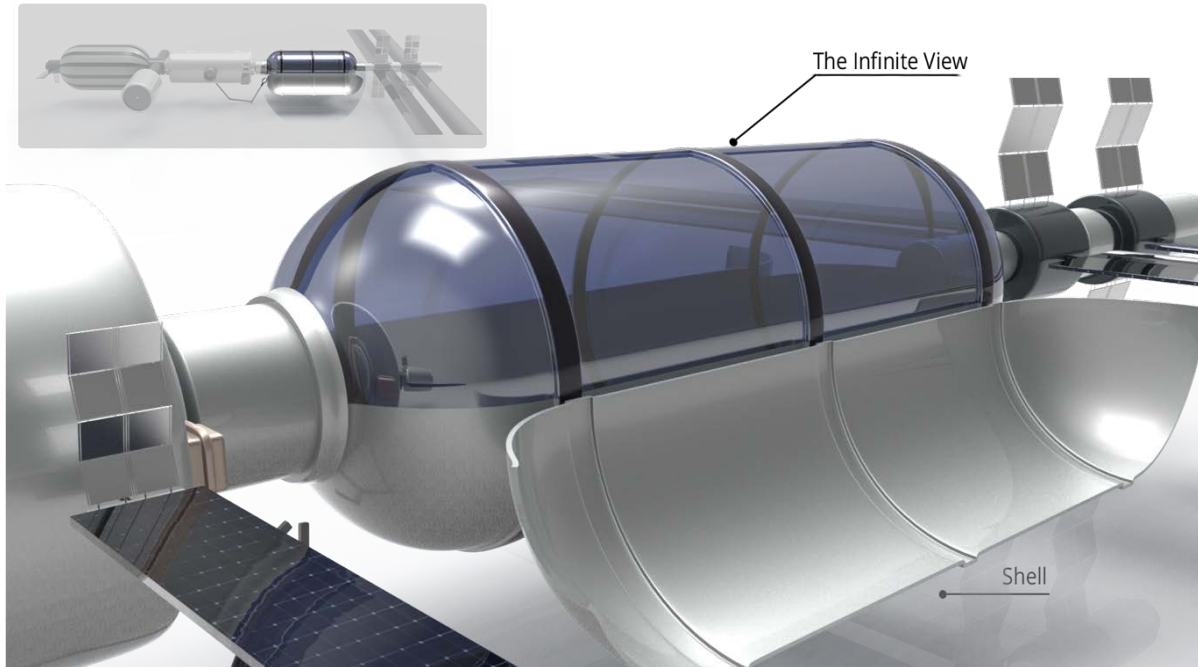

Fig.7 Design of The Infinite View Module

The lower part of the module will be made up of mostly aluminium since aluminium and its alloys have been tested and used in other space vehicle applications. The module will be followed by the Solar panels with possible expansion for the Solar panels as well (Discussed in the following sections). The robotic arm available on the lower surface of the Centre Module can grab to rails in the lower part of The Infinite View Module so that the range it can be utilised can be maximised. This helps to assemble the on coming solar panels to the Space vehicle from this module.

## 2. Design Solutions:

The main problems which could be faced because of having a transparent ALON structure is the Micro Meteorites which could hit the window. So we decided to use 2 pieces of structure called 'The Shell' to cover the transparent ALON Material. The Infinite View will remain closed during specific timings in a day. The transparent structure itself will be split into 8 parts as shown in the upcoming pictures. They are connected and supported with Structures running in between them. According to the current technology, making transparent structures using ALON which are big is not entirely possible. But we are considering that if investment and researches are made in this field, then it is very much possible. We don't want to sacrifice the customer's view by adding more structures and therefore insist on engineering the glasses according to our needs. Currently, the Cupola module of the ISS has a window made up of this material.

The Kitchen is built in this module. One of the problems we faced, was storing food and water in the module such that you the guest don't need to go down to the Storage section of the module to get it. So we designed Modular Cylinders which can be filled with food and water



and can be fitted from below (Storage place) such that opening a lid from the top section of the module will give access to the storage of the cylinders.

Another major problem could be a situation where the glass breaks. Although, the shells protect the Glass panels, they are not pressurised so if the transparent layer breaks then it will be of risk for Humans. So we designed the entrance between the Centre Module and The Infinite View module (TIVM) in such a way that there are 2 paths, One leading to the top section and the other leading to the Storage section of TIVM. The 2 sections are independently pressurized, so if the transparent section of the top section tend to break, the crew and the guest can move to the storage section and leave the module to the centre module.

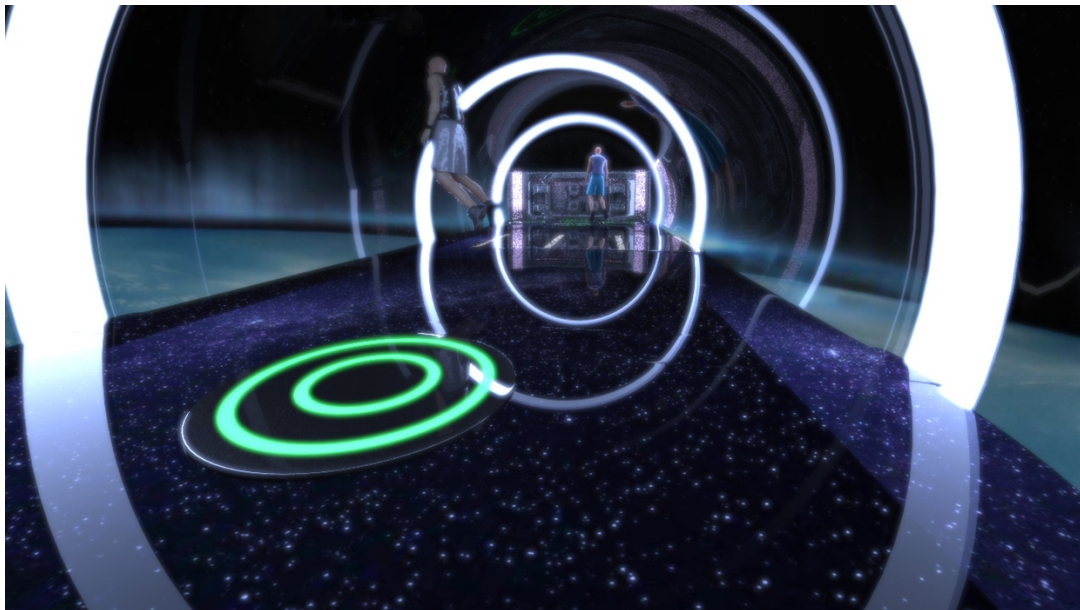

Fig.8 Visualisation of The Infinite View

For enabling movement of the on-board passengers and crew, handles are provided and placed in specific regions which are in reach (Not shown in the above picture). The handles are Back lit with LEDs, also the Storage compartments as shown in the above picture. The lights are placed with diffusing panels so that the light is dispersed around the complete interior. This also prevents from irritating the eyes of the people due to direct light from the source. The module is big enough for the passengers to float around and give them the pleasure to experience the Earth from a different perspective for the First time. There is a storage cylinder for the entertainment utilities (Shown in the picture above). In this, things like soft balls, small experiments, Frisbees and other entertaining contents which are considered to be safe are stored.

The Kitchen is made available for the customer only since the crew will have their own kitchen/place to prepare their food in the Crew module which will be dicussed further in the next section. This module will be the last pressurised module to assemble and hence there will not be any solar panels attached to this them. This module will be assembled with the help of the robotic arm that is present in the centre module / Guest module.



Fig.9 Visualisation of The Infinite View

The storage part of the module (as seen from the picture below), is carefully designed such that the volume available can be utilized to its maximum. The Storage bags and cylinders, can be brought with the passengers to the hotel. Then they are moved from the centre module where the docking ports are, to TIVM. The cylinders for food and entertainment utilities are placed in such a way that they align with the lids shown in the picture picture above. The bags with other placed around the perimeter of the module in the storage compartment.

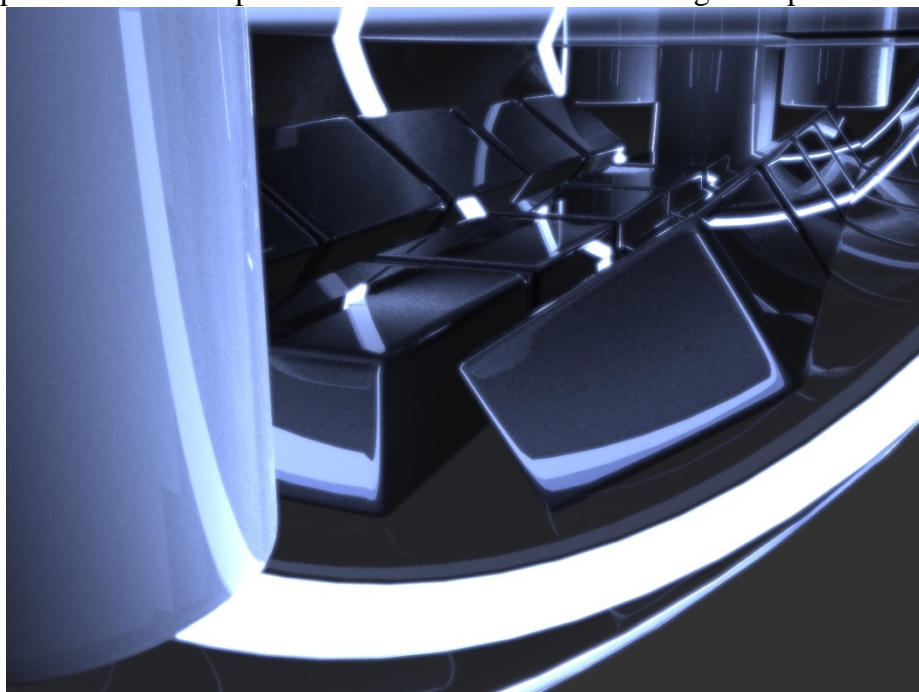

Fig.10 Storage of The Infinite View Module



## C. Crew Module

For the crew module it was decided the innovative BA 330 inflatable module designed by Bigelow Aerospace<sup>[4]</sup> would be used. This decision was based on the premise it will be launch able by 2017 which agrees with our limitation of launching no later than in 2022. This module is also expected to have a lifespan of 20 years which corresponds to the lifespan expected for most modules in our Space Hotel. BA 330 was chosen specifically because of its availability and facilities. It comprises accommodation for up to 6 crew members as well as gym facilities, spare parts storage and a control room.

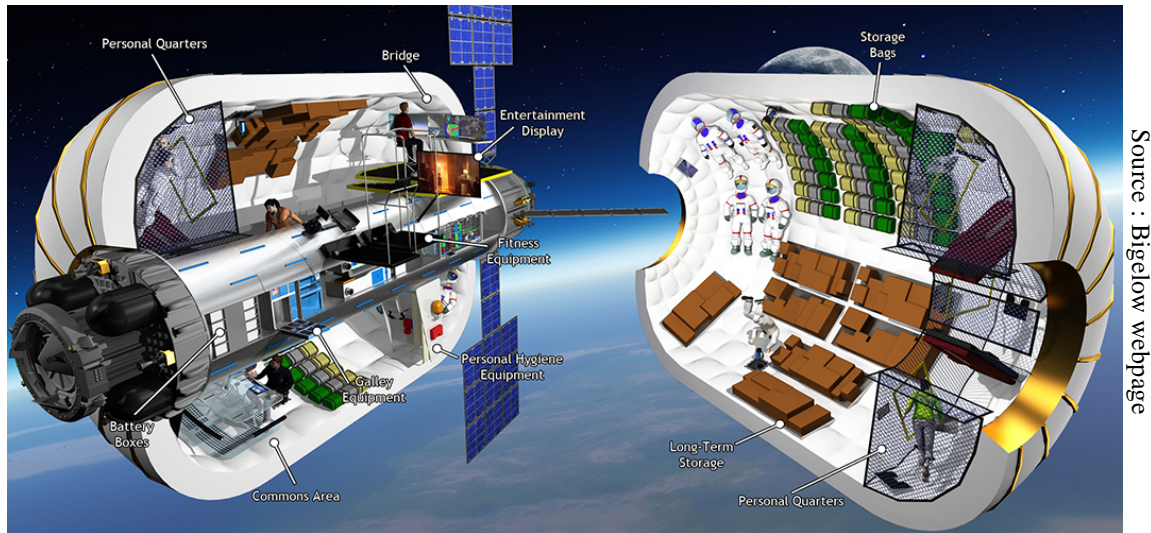

Fig.11 BA 330

This module is inflatable, which means it occupies a lesser area at launch, meaning lesser launches are required for assembling the Station and lesser overall costs. It is a relatively new technology however it is proven to be equivalent or better at providing radiation shielding than existing ISS modules.

BA 330 is also equipped with thrusters powerful enough for the module to be able to independently arrive to the station's location and dock itself. These thrusters are always operational, which means in addition to this initial use, this module's thrusters can also be used for altitude control, compensating for the Dragon's thruster's direction limitations.

Some changes would be made to adapt it to the concept at hand. It was decided there would only be a maximum of 4 crew members (before possible expansion of the hotel) hence the extra rooms could be changed to storage compartments for spare parts or even scientific-experience laboratories, for extra income or even extra activities for the customers.

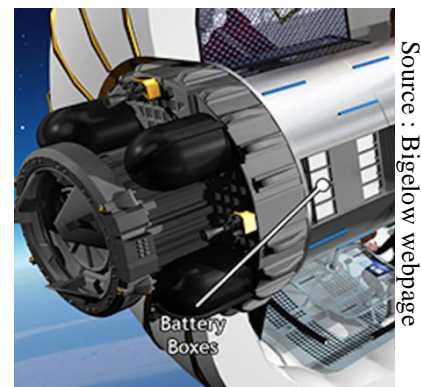

Fig.12 BA 330 Thrusters

## D. EVA Module and Expansion Node

### 1. Concept:

Countermeasures are important in every type of project, and when it comes to human habitat in space, it is of extreme necessity that the project is prepared for off nominal cases. With that in mind, the possibility of an Extra Vehicular Activity (EVA) is an indispensable feature for this project. EVAs will permit regular and emergency maintenance when the robotic arm alone is not able to do so. It will also provide another activity for our guests too.

### 2. Design Solutions:

The EVA module designed for this project was highly inspired on the Guest Joint Airlock module currently in use in the ISS<sup>[3]</sup>. The module is divided into two segments: a storage for the suits, and a crew segment from which astronauts can exit the hotel. The second segment also provides a special environment, where astronauts can be prepared to avoid decompression sickness. With the use of hard suits, this preparation time can be reduced.

The module was designed to have a cylinder form, with 5.5 meters of length and a diameter of 4 meters. The structure is mostly made of aluminium. This follows designs already tested in space. The module is connected to the rest of the hotel through a connection module.

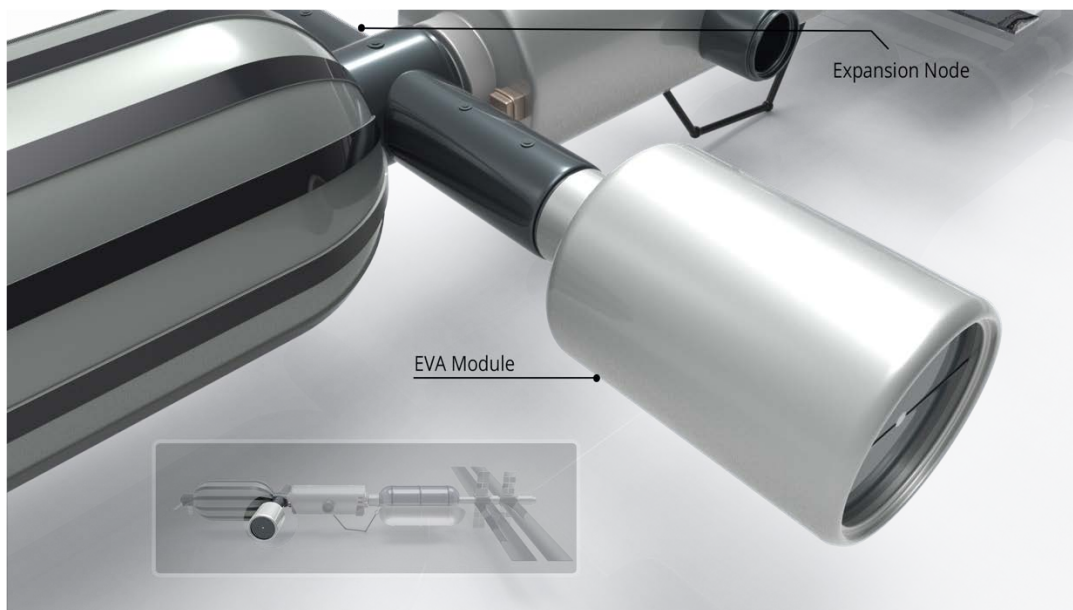

Fig.13 EVA Module & Expansion Node

The node module connects the EVA module with the guest and crew module. It also has another possible connection for future expansion, if necessary. It was based in the Unity module, present in ISS, which is also used as a connection module. It has a cylindrical shape with 5 meters' length and a diameter of 4 meters, and it is mostly manufactured in aluminium.

All the mass estimations were made comparing with existing modules, some approximations were made to give reasonable reliability for this part of the project.



## E. Solar Panels

### 1. Concept:

Electricity plays an important role in a human space mission. It is needed in several indispensable processes that maintain the habitat suitable for human life. The best option to generate this energy is probably through solar cells, since it is considered a safe approach to produce energy, especially if you compare to others available technologies, such as nuclear power plants. Solar light is readily available in space during a segment of the hotel's orbit, and the excess energy can be stored in batteries for the other segment.

### 2. Design Solutions:

The amount of power necessary was calculated through a comparison with the International Space Station. The hotel has approximately half of the size of the ISS, it was decided that a total amount of 40kW was enough to give a good margin of security. For generating this power, the hotel will use two solar arrays wings. The technology used will be the same as the ones currently in use at ISS; however a modification will be done in order to use triple junction cells.

The main solar panels will be located at the right end of the hotel. This decision was made in order to avoid problems during docking and guest's EVAs. With the solar panels in this position, we can make use of unpressurized modules to support them, since it will not connect the hotel with others modules.

The solar array wings can be folded for saving payload space during launch. When mounted in the hotel it will spread out to its full length. One solar array wing has a length of thirty five meters and a width of six meters. Altogether, the main solar panels have 420 square meters of solar cell's area.

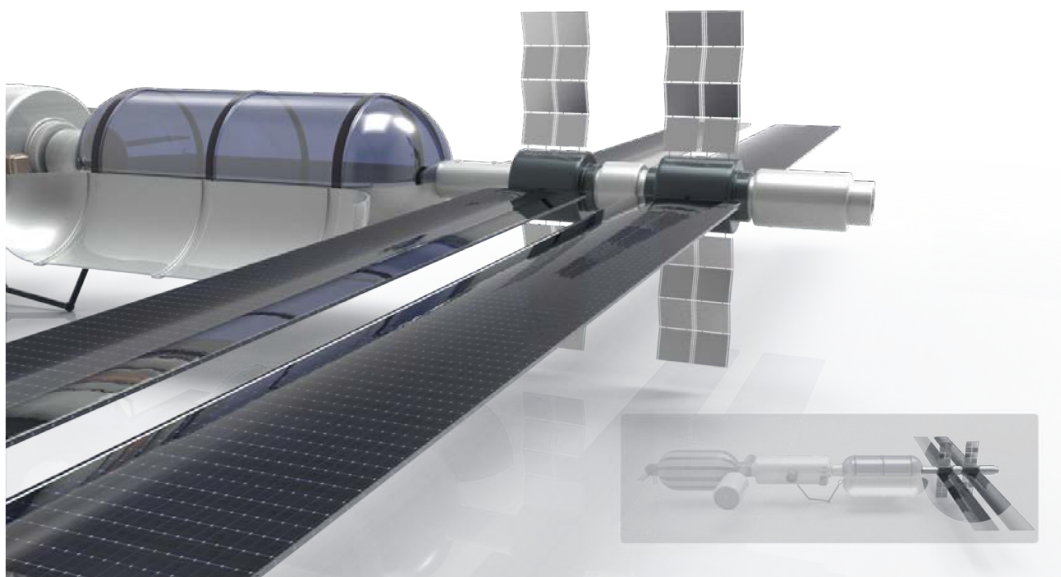

Fig.14 Solar panels Module

The crew and guest modules are also equipped with small solar panels, making them self-sufficient during the assembly of the hotel. After the assembly, these solar panels will be folded to avoid interference during the docking of others spaceships. These extra solar panels can be also using in case of emergency.

### III. Other Aspects

#### A. Robotic Arm

##### 1. Concept:

For the assembly of the station and subsequent maintenance it was decided a robotic arm, although expensive would be best suited.

##### 2. Design Solutions:

A version of the canadarm2 in use at the ISS was considered the most useful. This arm is capable of handling large payloads and has the ability to assembly a whole station. It has latches on either end, allowing it to be moved from one tip of the station to the other. This robotic arm can either be controlled by the crew or in a ground station.

This robotic arm can be used not only for assembly and direct maintenance but also for assistance of more delicate maintenance work, when an astronaut is required to do some external work on the station the robotic arm can help place the astronaut in the spot he needs to be at and help him stay still in that one place, thus ensuring the best work conditions for the astronaut.



Source : Nasa webpage

Fig.15 Canada Arm

For our concept some changes would be made to the model in use at the ISS. They would be made according to the extra room available in the launch of the guest module. These shall be launched together to enable automated assembly. Our robotic arm will have nine motorized joints, each part 1.5m long, summing up to a total length of 9m.

## B. Attitude Control:

### 1. Concept:

Attitude Control is needed on a spacecraft for various reasons. For our aircraft we wanted to ensure that the Infinite View open window part would always face the Earth. The position of the solar arrays and radiators in relation to the sun and the direction of the antennas all depend on the attitude control of the station.

### 2. Design Solutions:

There are many solutions for attitude control in spacecraft. One is spin-stabilization. This option is not viable because the customers could feel ill when looking out the Infinite View window.

Another option is to use small propulsion-system thrusters to nudge the station back and forth within a deadband of allowed attitude error. A third option could be to use momentum wheels. They provide a means to trade angular momentum back and forth between the spacecraft and the wheels.

For attitude control of our station we will use a CMG (Control Momentum Gyroscope), the previously mentioned momentum wheels. For the CMG system two wheels will be used, each one placed on one side of the guest module. There will also be two spares available in case of malfunctioning.

The thrusters of the guest module will also be used to compensate any limitation of the wheels functioning.

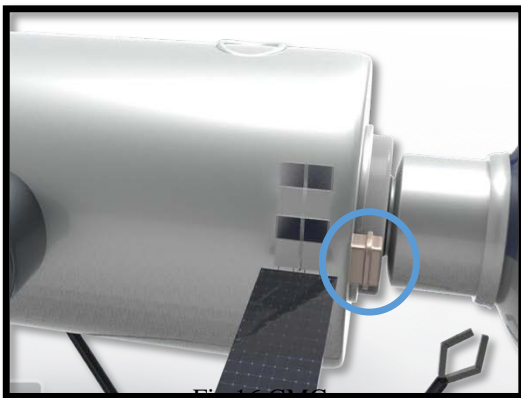

Fig.16 CMG

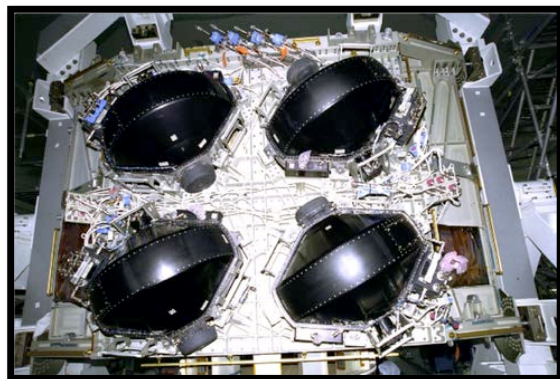

Fig.17 Momentum Wheel

Source : Nasa webpage

## IV. Mass Estimates

The mass estimates in the following table were made with certain approximations and comparing it with the existing modules in the ISS<sup>[3]</sup> and the other components that have been already designed and sent to space.

Bigelow B330 module	20000 kg
Guest module	25000 kg
EVA node module	25000 kg
TIV module	20000 kg
Solar panels module	14000 kg
Robotic arm	300 kg

Table 1: Mass Estimates

## V. Conclusion

The preliminary design of the space vehicle presented here, considers the Self Sustainability of the modules, Power, Smart storage sections, Passenger comfort, Elegant interiors and the Splendid viewing Experience. The design took several approximations into consideration such that the Transparent structure found in the Infinite View module will require more Engineering perspective and also the mass estimates was made comparing the other components which were sent to space. Further, we collaborated with Mission team to Size our modules, the Human aspects team for the understanding the requirements of EVA for the EVA module and the overall coordination team to structure the Cost of the Vehicle. We would like to thank everyone who have helped us with their support and advise.

## VI. References

- [1] <http://www.spacex.com/falcon9>
- [2] P. Collins. Space Hotels, Civil Engineering's New Frontier. [http://www.spacefuture.com/archive/space hotels civil engineerings new frontier.shtml](http://www.spacefuture.com/archive/space%20hotels%20civil%20engineerings%20new%20frontier.shtml)
- [3] NASA. International Space Station. [http://www.nasa.gov/mission page/station/main/index.html](http://www.nasa.gov/mission_page/station/main/index.html)
- [4] Bigelow Aerospace. B330 module. <http://bigelow-aerospace.com/b330/>





Mother Earth Re-Designed by Kavithasan Patkunam