



ROYAL INSTITUTE  
OF TECHNOLOGY

# Semiconductor Devices, Fall 2014

Gunnar Malm, Associate Professor  
Integrated Devices and Circuits, Kista Campus  
[gunta@kth.se](mailto:gunta@kth.se), 08-790 4332



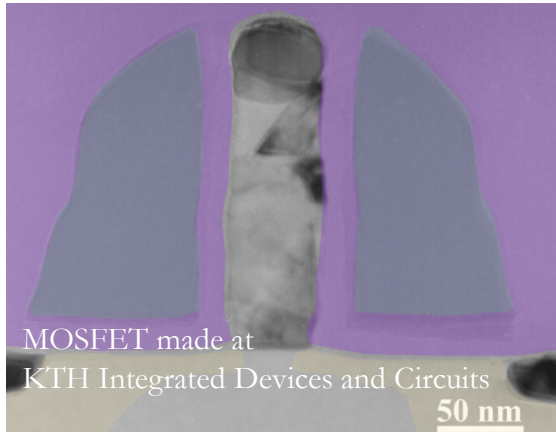
ROYAL INSTITUTE OF TECHNOLOGY



Semiconductor procesing at KTH Electrum Laboratory

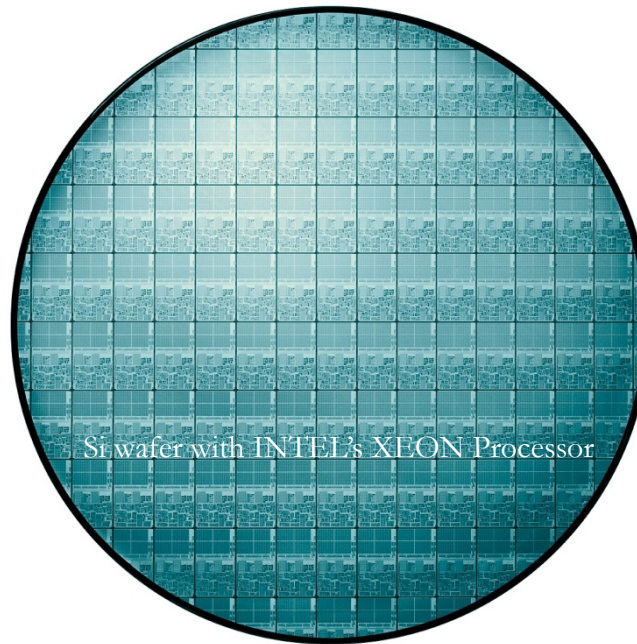


Stepper Lithography at KTH Electrum Laboratory

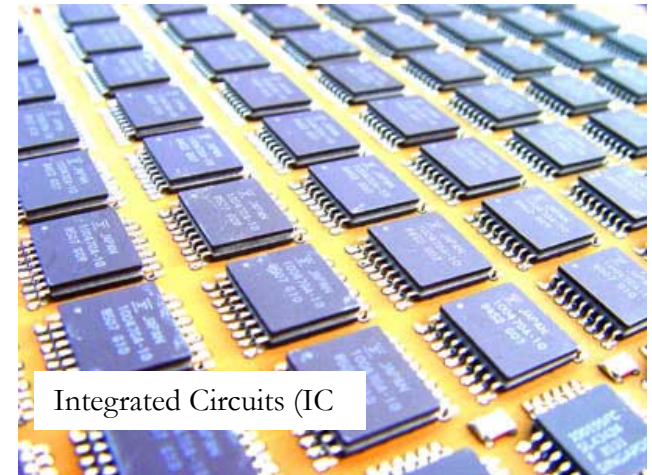


MOSFET made at KTH Integrated Devices and Circuits

50 nm



Si wafer with INTEL's XEON Processor



Integrated Circuits (IC)

# Today's lecture & introduction

- Course info (approx first hour)
  - Semiconductor material properties and **history**
  - Concepts
    - Conduction electrons in a SC crystal
-



ROYAL INSTITUTE  
OF TECHNOLOGY

## Course goals

The overall goal of the course is that you should be able to describe the function of the pn-diode, the bipolar and the MOS transistor and how these three devices are used in applications. You should be able to derive and calculate the currents inside these devices and be able to analyse the internal state of the charge distribution, the electric field and the current density.

In detail, after a successful completion of the course you will be able to:

1. qualitatively describe the electronic energy band structure of insulators, semiconductors and metals
  2. calculate the electron and hole concentration in the conduction and valence band using Fermi-Dirac statistics and the energy band model.
  3. describe the constituents of the current density in semiconductors and derive analytical expressions for the current density in the case of low-level injection, electron-hole recombination, externally applied voltage and external generation by light, using the drift-diffusion model.
  4. describe the function of the pn-diode, the bipolar and the long channel MOS transistor.
  5. analyse and calculate the internal electrostatics (electric charge, electric field and potential) of the pn-diode, the bipolar and the long channel MOS transistor.
  6. derive and calculate the current density in the pn-diode, the bipolar and the long channel MOS transistor using the drift-diffusion model.
  7. describe major process technologies, used to fabricate semiconductor devices and relate these to schematic cross-section drawings of devices.
  8. extract device properties from electrical measurements of devices.
  9. perform oral and written presentation of the subject Semiconductor Components.
-



ROYAL INSTITUTE  
OF TECHNOLOGY

## Lectures

There are *Reading Instructions* at the end of this course-PM. The lectures are based on the assumption that the students have read according to Reading Instruction *before the lecture*. During the lectures there will be sections that require *active participation* by the students.

## Student recitations

There are 6 student recitations in the course.

At the *first lecture 6 sheets containing 6 problems* (totally 36 problems) are distributed. The sheets are numbered as S1, S2, S3, S4, S5 and S6. Before each student recitations the student should try to solve the 6 problems on the sheet related to the student recitation in question. The *student* should also *prepare* to present the *solution on the board* for the class.

*The level of difficulty of the problems on the student recitation is the same as on the written exam.*

---



ROYAL INSTITUTE  
OF TECHNOLOGY

## Student recitations

There are 6 student recitations in the course.

At the *first lectures 6 sheets containing 6 problems* (totally 36 problems) are distributed. The sheets are numbered as S1, S2, S3, S4, S5 and S6. Before each student recitation the student should try to solve the 6 problems on the sheet related to the student recitation in question. The *student* should also *prepare* to present the *solution on the board* for the class.

*The level of difficulty of the problems on the student recitation corresponds to the written exam.*

In detail a student recitation is organized as follows:

1. At the beginning of the student recitation each student will put a cross on a list to indicate which of the 6 problems he/she is prepared to present to the class
2. One student is randomly picked to present each problem.
3. After the solution has been presented there is a discussion, in which all students are expected to participate. Students are expected to give feedback on the presented solution and possibly provide alternative solutions.
4. When the discussion is finished a new student presents a solution to the next problem
5. When all 6 problems have been presented and discussed the student recitation ends.

The number of crosses a student has on the list indicates how many problem the student has solved. The total number of problems is 36. To *be allowed* to attend *the written exam* the student has to acquire a *minimum of 20 crosses* after the 6 student recitations.

---

## Laboratory work, seminars and report

Course lab includes a laboratory exercise in groups of four students. The place of the lab is in the Electrum building, elevator C, level 4. Labs will be scheduled by signup in the Daisy portal. During two hours measurement *data are collected* under the guidance of a lab assistant. After the lab, *each student independently determines device parameters* from measurements. Each student receives an individual assignment and will write an individual lab report that presents the measurements, the extraction procedure and the results. Method, results and conclusions must be clearly outlined. Results should be commented on regarding accuracy and students are expected to reflect on the relationship between measurements and theory. Results should be reported with well-structured diagrams, graphs and tables. A good lab report should be clear, as well as linguistically well-written. The *first seminar deals* with *extraction procedure* and with *report writing*.

The *laboratory report* should be sent by *email* to the *course responsible* in PDF before the *first deadline* stated in the schedule at the end of this course-PM.

The laboratory report will be tested for *plagiarism* of the course responsible. All students will receive an email with *three laboratory reports*. These should be read and about half a page *constructive feedback* must be *prepared before the feedback seminar*. The written feedback should be brought in two copies (one to their peers and one to the course responsible) to the *feedback seminar* (date and time is given in the schedule at the end of this course-PM). At the feedback seminar each student will give (to their peers) and receive (from their peers) feedback on their reports. After the seminar students can *improve* their reports and the *final report* should be sent in to the course responsible before the *second deadline* stated in the schedule at the end of this course-PM.

---



ROYAL INSTITUTE  
OF TECHNOLOGY

## Individual meeting with teacher

During the course any student is always welcome to contact the course responsible for any type of question. Preferably this should be done by email. There are, however, *two scheduled times* for students to *individually meet* a teacher to discuss anything the student finds troublesome to understand in the course. During the lectures there will be a list to sign up for a time to meet a teacher.

---





ROYAL INSTITUTE  
OF TECHNOLOGY

## Examination

The course has three examinations that examine the course goals.

1. Laboratory report (1,5 credit Pass/Fail)
2. Student recitations
3. Written examination. (6 credit and A-F grades)

### Laboratory report

The Laboratory work is awarded 1,5 credit. The grade on the Laboratory work is Pass/Fail. To be awarded the grade pass the student needs to participate in the laboratory session, the feedback seminar and file an individual laboratory report before the deadline.

### Student recitations

To be allowed to attend the written exam the student has to acquire at least 20 crosses during the 6 student recitations.

### Written exam

The written exam consists of 6 problems which are similar to the problems dealt with on the student recitations. There are also two questions that deal with the theory of semiconductor components which require a texted answer. Each problem/question gives a maximum of 4 points. To get the grade E a total of 16 points is required. The allowed time on the written exam is 5 hours. The students are only allowed to bring “IH1611 Material Properties and formulas” and a calculator to the written exam. Date and time for the written exam is given in the schedule at the end of this course-PM.

---



ROYAL INSTITUTE  
OF TECHNOLOGY

# Teachers and additional information

## Course responsible

Associate Professor, Docent. Gunnar Malm, 08-790 4332, School of ICT, Integrated Devices and Circuits, Electrum C4 (Kista)

## Teachers and lab assistant

Mattias Ekström, [mekstr@kth.se](mailto:mekstr@kth.se) Student recitations 1-6.

Assistant XX, laboratory sessions, 2h per group of four students.

## Examiner

Associate Professor, Docent. Gunnar Malm, 08-790 4332, School of ICT, Integrated Devices and Circuits, Electrum C4 (Kista)

## Course prerequisites

Electromagnetic theory, electric circuit theory, introductory solid state physics, introductory quantum mechanics alternatively thermodynamics with statistical physics, basic chemistry.

## Course literature

*Modern Semiconductor Devices for Integrated Circuits*, Chenming Calvin Hu, 2010, Pearson Education, ISBN-10: 0-13-700668-3.

---

# What is a semiconductor?

Explore **key information** about the chemical elements through this periodic table

Group	1	2	3	4	5	6	7	8	9	10	11	12	13	14	15	16	17	18																								
Period																																										
1	1 H																	2 He																								
2	3 Li	4 Be											5 B	6 C	7 N	8 O	9 F	10 Ne																								
3	11 Na	12 Mg											13 Al	14 Si	15 P	16 S	17 Cl	18 Ar																								
4	19 K	20 Ca	21 Sc	22 Ti	23 V	24 Cr	25 Mn	26 Fe	27 Co	28 Ni	29 Cu	30 Zn	31 Ga	32 Ge	33 As	34 Se	35 Br	36 Kr																								
5	37 Rb	38 Sr											39 Y	40 Zr	41 Nb	42 Mo	43 Tc	44 Ru	45 Rh	46 Pd	47 Ag	48 Cd	49 In	50 Sn	51 Sb	52 Te	53 I	54 Xe														
6	55 Cs	56 Ba	*										57 La	58 Ce	59 Pr	60 Nd	61 Pm	62 Sm	63 Eu	64 Gd	65 Tb	66 Dy	67 Ho	68 Er	69 Tm	70 Yb	71 Lu	72 Hf	73 Ta	74 W	75 Re	76 Os	77 Ir	78 Pt	79 Au	80 Hg	81 Tl	82 Pb	83 Bi	84 Po	85 At	86 Rn
7	87 Fr	88 Ra	**										89 Ac	90 Th	91 Pa	92 U	93 Np	94 Pu	95 Am	96 Cm	97 Bk	98 Cf	99 Es	100 Fm	101 Md	102 No	103 Lr	104 Rf	105 Db	106 Sg	107 Bh	108 Hs	109 Mt	110 Ds	111 Rg	112 Cn	113 Uut	114 Uuq	115 Uup	116 Uuh	117 Uus	118 Uuo
			*	57 La	58 Ce	59 Pr	60 Nd	61 Pm	62 Sm	63 Eu	64 Gd	65 Tb	66 Dy	67 Ho	68 Er	69 Tm	70 Yb																									
			**	89 Ac	90 Th	91 Pa	92 U	93 Np	94 Pu	95 Am	96 Cm	97 Bk	98 Cf	99 Es	100 Fm	101 Md	102 No																									

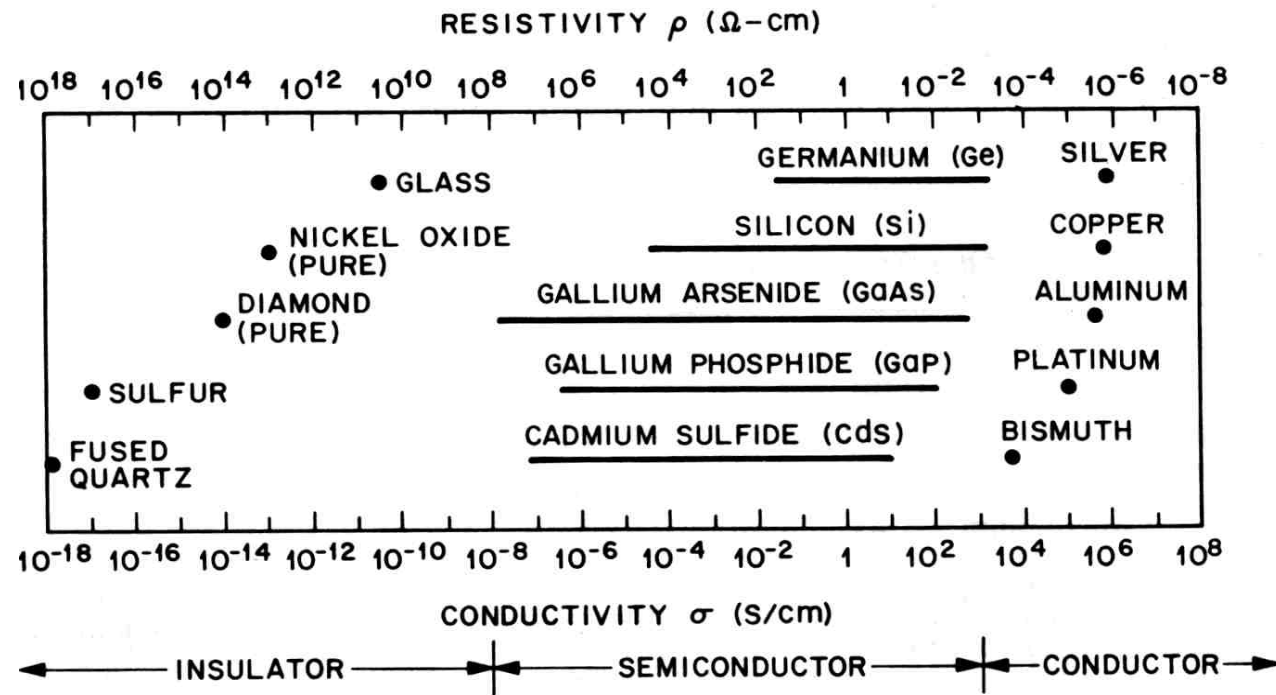
- Elements in the periodic system with the right electronic properties, determined by the group (valence number)
- Silicon(Si) by far the most common/ well-known
- Used in microelectronics in various types of devices and in all integrated circuits including memories

- Which of the following statements are correct?
  - A) The semiconductors were discovered before electronics
  - B) Analog electronics can be realized without semiconductors
  - C) Digital electronics can be realized without semiconductors
  - D) Radio development pushed the semiconductor technology

Are you sure about your answer?

- I am guessing
  - I am quite sure
  - I am correct
-

# Conductive properties of materials



**Fig. 1** Typical range of conductivities for insulators, semiconductors, and conductors.

A list of symbols is given in Appendix A.

- Which of the following statements are correct?



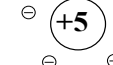
For a **semiconductor you can easily change the conductivity by the following means:**

- A) Changing the temperatures
- B) Changing the lightning ambient
- C) Adding impurities to the material
- D) Changing the pressure (acting on the sample)

Are you sure about your answer?

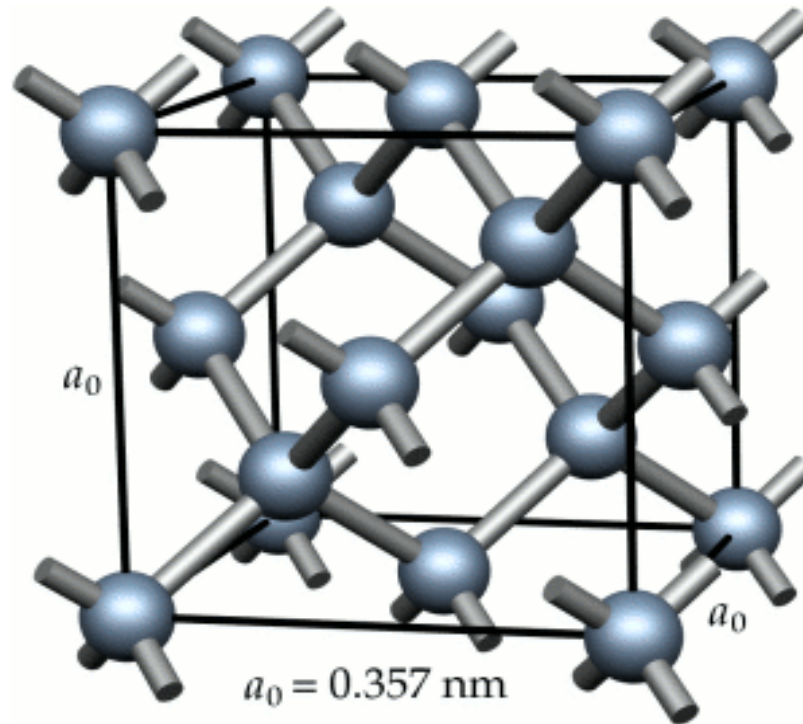
- I am guessing
  - I am quite sure
  - I am correct
-

## Columns III, IV och V

III		IV		V	
					
5	<b>B</b> <b>Boron</b> 10.82	6	<b>C</b> <b>Carbon</b> 12.01	7	<b>N</b> <b>Nitrogen</b> 14.008
13	<b>Al</b> <b>Aluminum</b> 26.97	14	<b>Si</b> <b>Silicon</b> 28.09	15	<b>P</b> <b>Phosphorus</b> 31.02
31	<b>Ga</b> <b>Gallium</b> 69.72	32	<b>Ge</b> <b>Germanium</b> 72.60	33	<b>As</b> <b>Arsenic</b> 74.91
49	<b>In</b> <b>Indium</b> 114.8	50	<b>Sn</b> <b>Tin</b> 118.7	51	<b>Sb</b> <b>Antimony</b> 121.8

- Elemental semiconductors in periodic table of elements column IV
- Compound SC using III och V, e.g. GaAs, InP
- Another interesting approach is two elements from column IV e.g. SiC, and SiGe

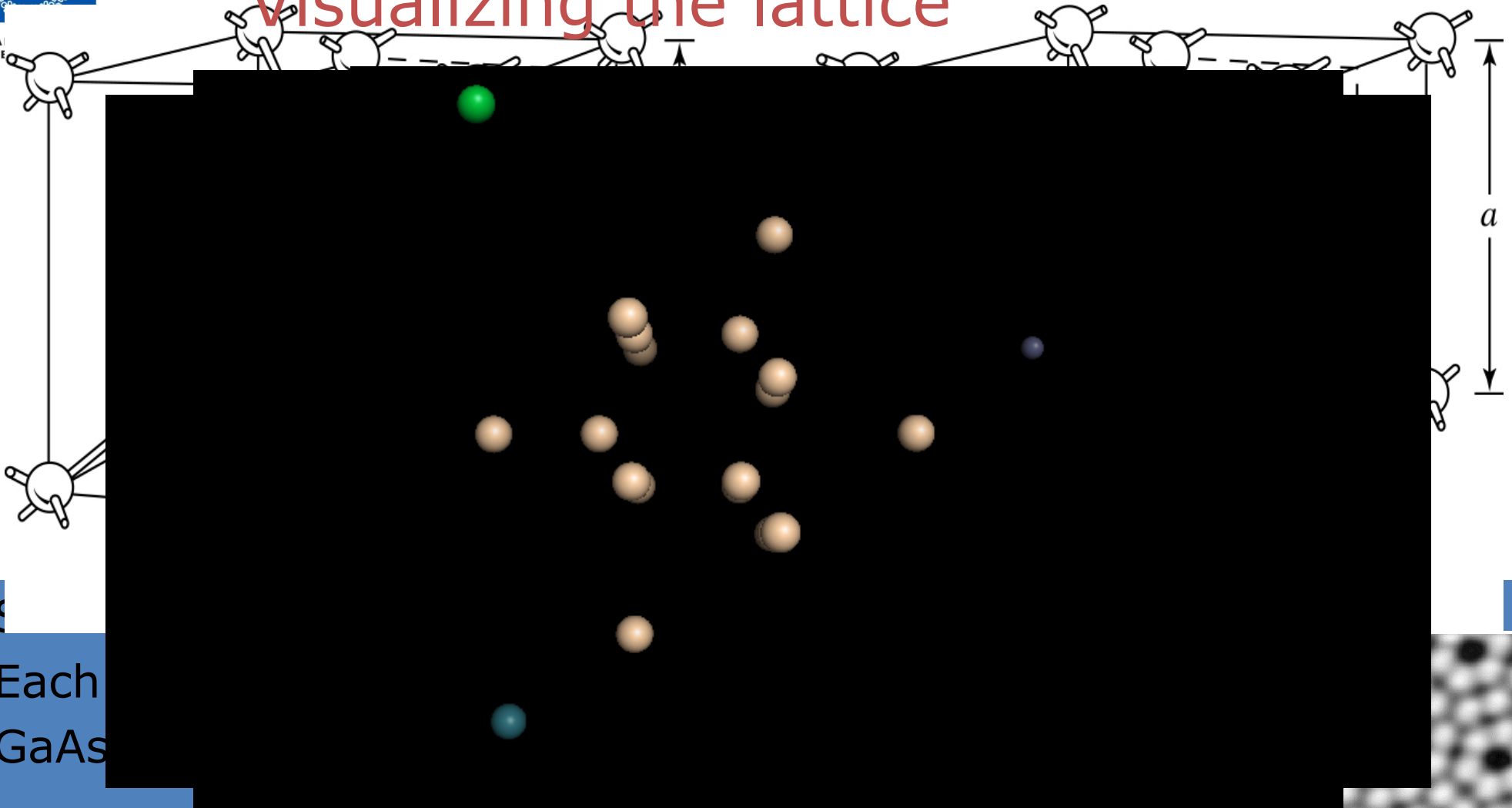
# Good semiconductors are crystals



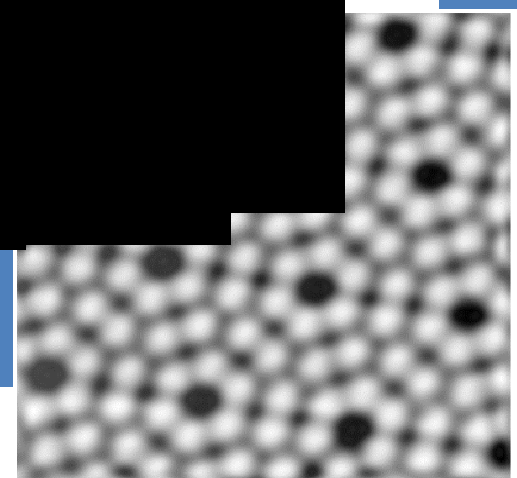
- Symmetry of silicon crystal lattice unit cell
- Organic and amorphous semiconductors have significantly lower conductivity!



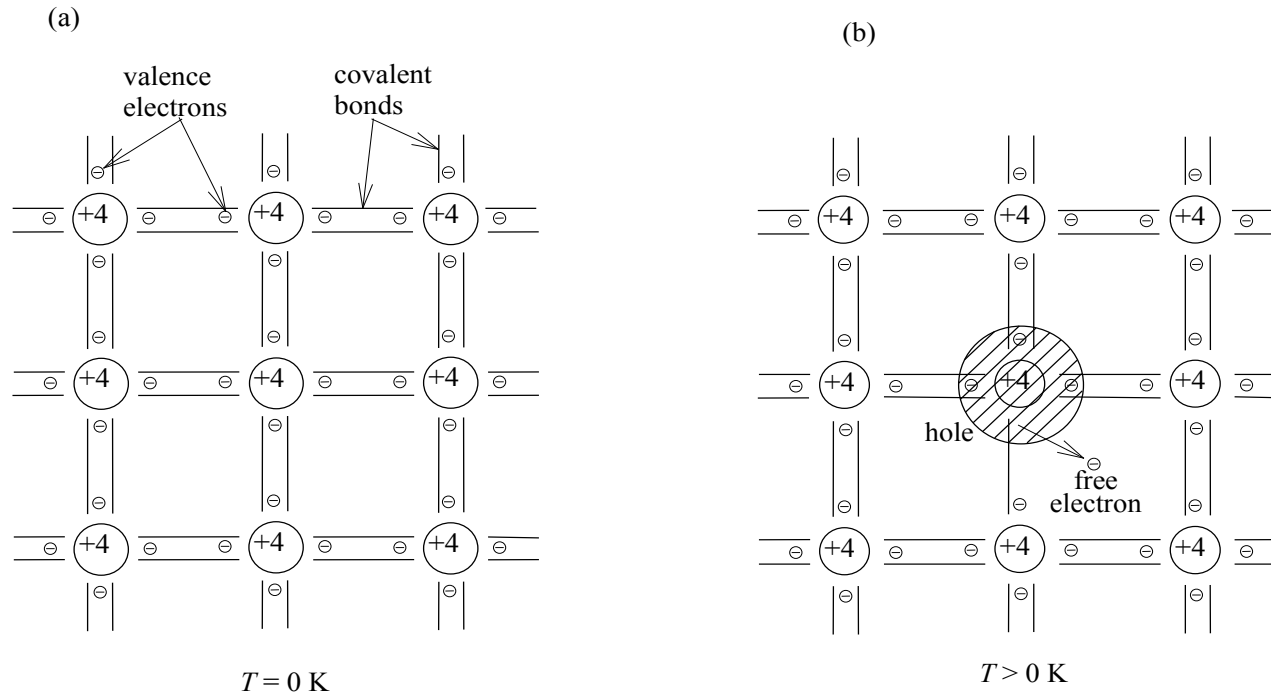
# Visualizing the lattice



- S
- Each
- GaAs

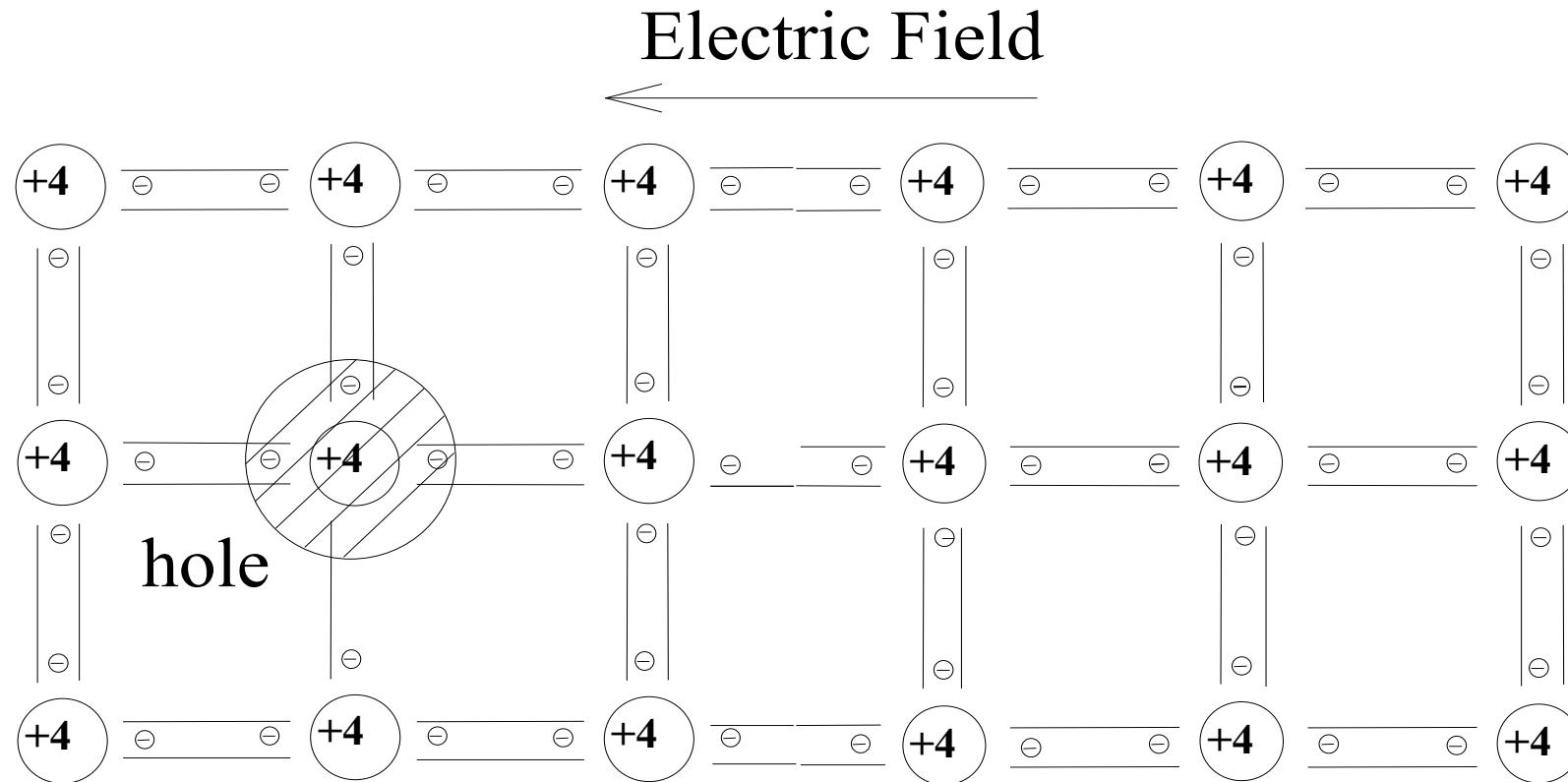


# Free Electrons (and holes)

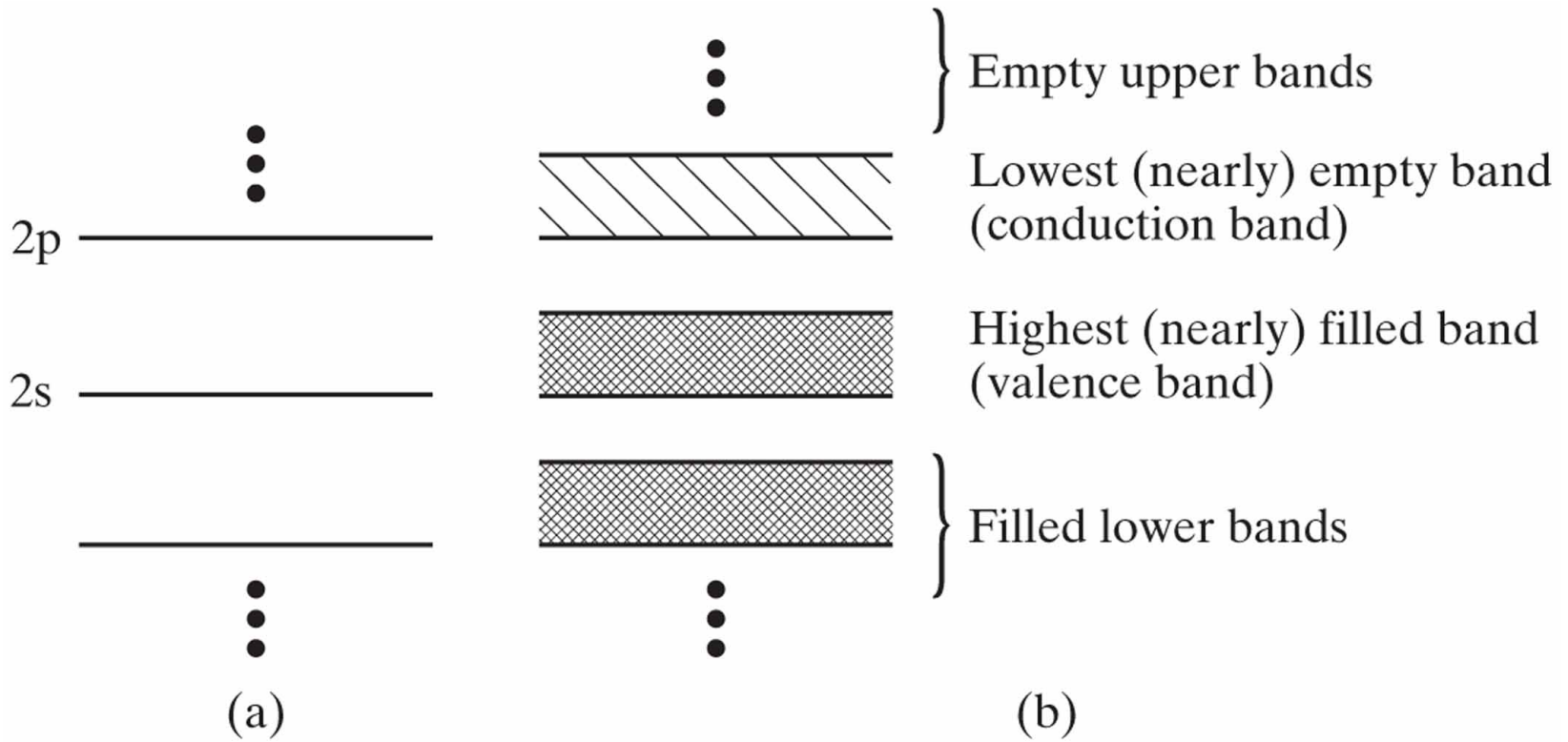


- Atoms in column IV have four valence electrons
- Thermal energy is sufficient to move electrons and leave holes behind

# Net current under applied field

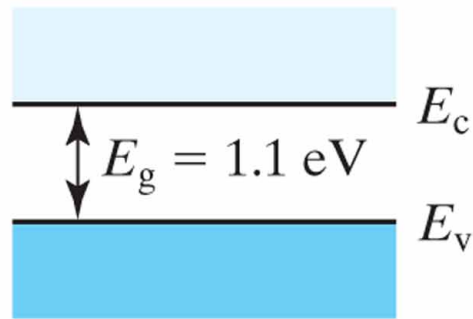


- Free electrons are able to move in electric fields and that results in a net current flow in the crystal
- Holes also move in the opposite direction

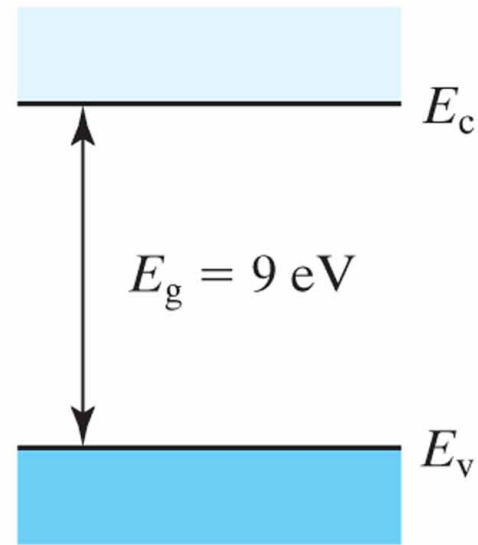


**TABLE 1-1 • Band-gap energies of selected semiconductors.**

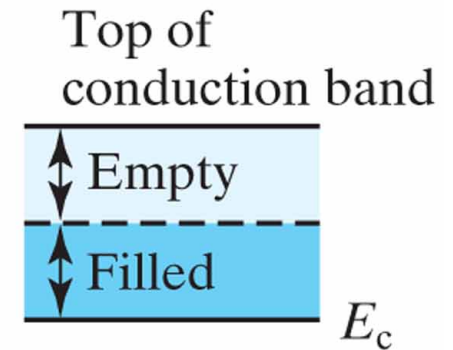
Semiconductor	InSb	Ge	Si	GaAs	GaP	ZnSe	Diamond
$E_g$ (eV)	0.18	0.67	1.12	1.42	2.25	2.7	6.0



(a) Si, semiconductor



(b)  $\text{SiO}_2$ , insulator



(c) Conductor

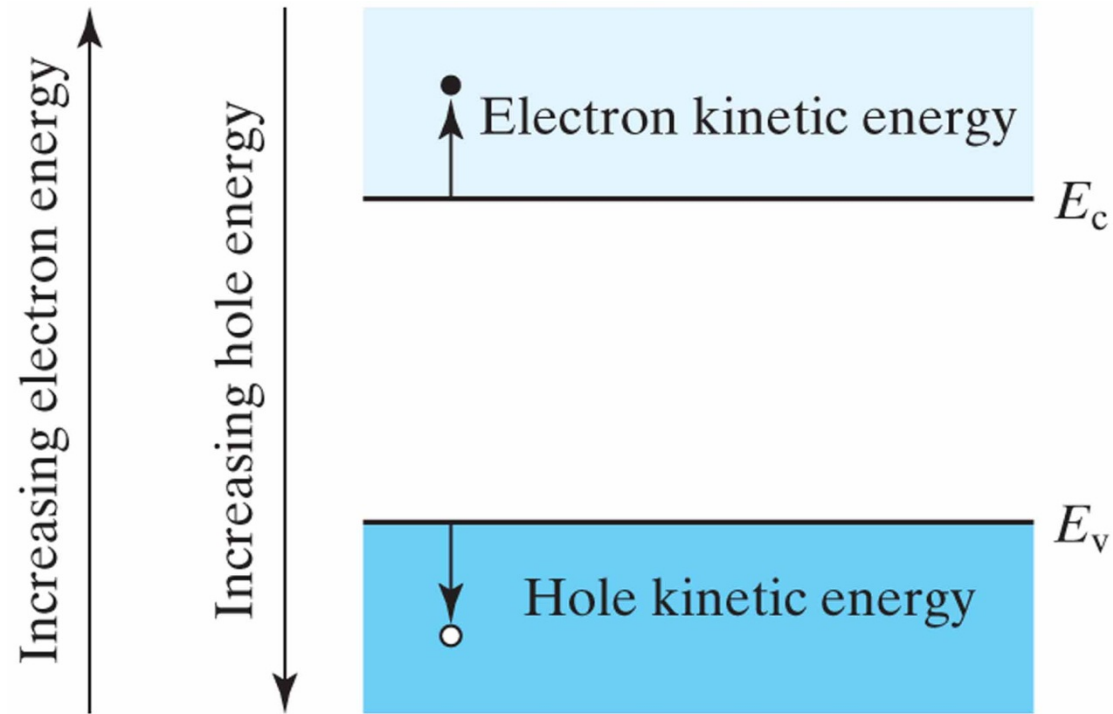
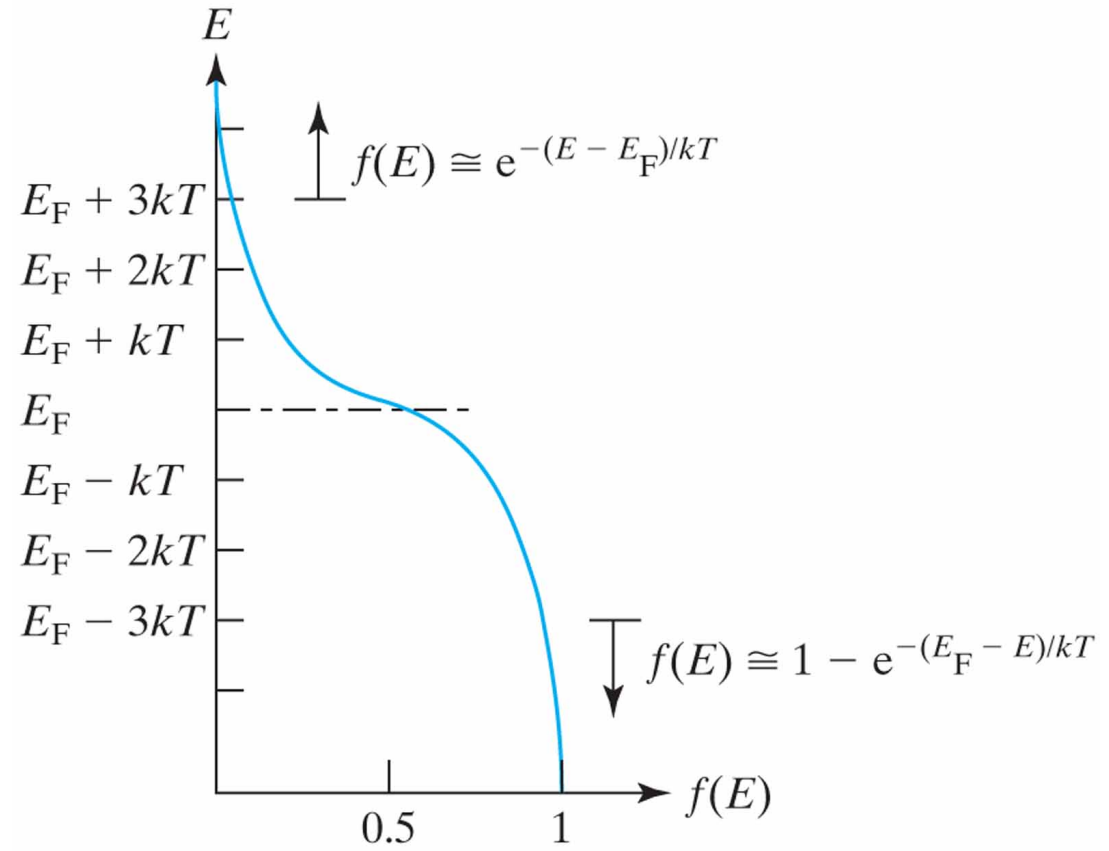
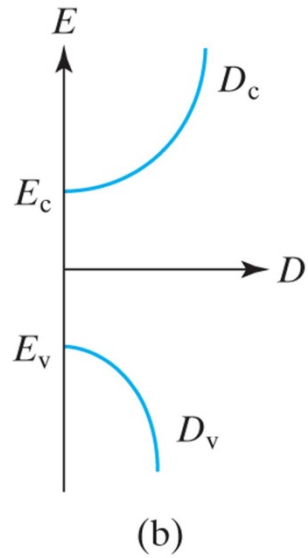
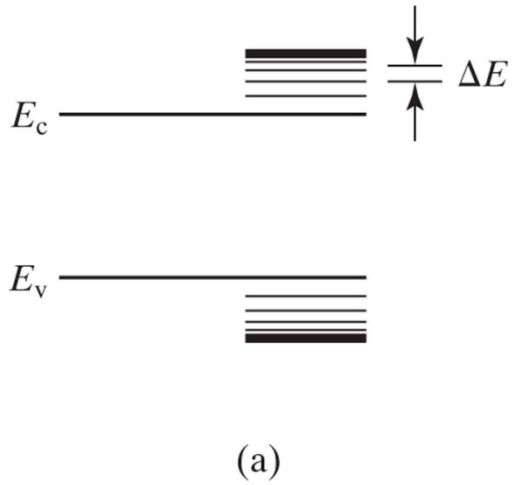


TABLE 1–3 • Electron and hole effective masses,  $m_n$  and  $m_p$ , normalized to the free electron mass.

	Si	Ge	GaAs	InAs	AlAs
$m_n/m_0$	0.26	0.12	0.068	0.023	2.0
$m_p/m_0$	0.39	0.30	0.50	0.30	0.3



# Next Lecture

- Reading 1.1-9 and 1.11, 2.1-2.2
  - Concepts:
    - Energy band model
    - Distribution functions and effective density of states
    - Intrinsic carriers and ionized dopant impurities
    - Charge neutrality
    - Drift current (applied field)
-