

**Offshore Technology**



**energynautics**  
solutions for a sustainable development

Thomas Ackermann, Ph.D.  
T.Ackermann@energynautics.com



**DIG SILENT**  
Expert User of DigSILENT PowerFactory for Power Systems Studies



**OFFSHORE POTENTIAL**



**energynautics**  
solutions for a sustainable development

2

**Technology Assumptions**



- **Water Depth: <50 m**
- **Area off limit: 50%**
- **WTG rated: 3 MW**
- **Inter-turbine spacing: 10 D**
- **Availability: 97%**
- **Cut-in: 3.5 m/s**
- **Nominal: 12.0 m/s**
- **Cut-out: 25 m/s**

3

**Area Off-limit:**



- **Natural conservation & recreation;**
- **Military use**
- **Dredging & mining concessions**
- **Dumping of dredging spoils**
- **Fishery**
- **Traffic**
- **Pipelines and cables**

4

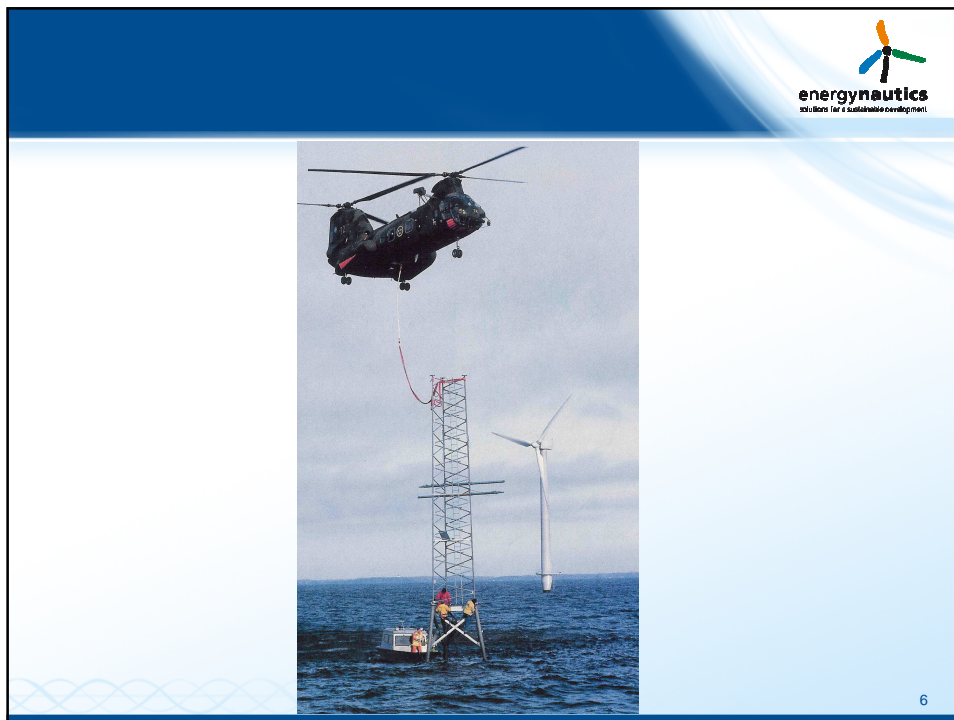
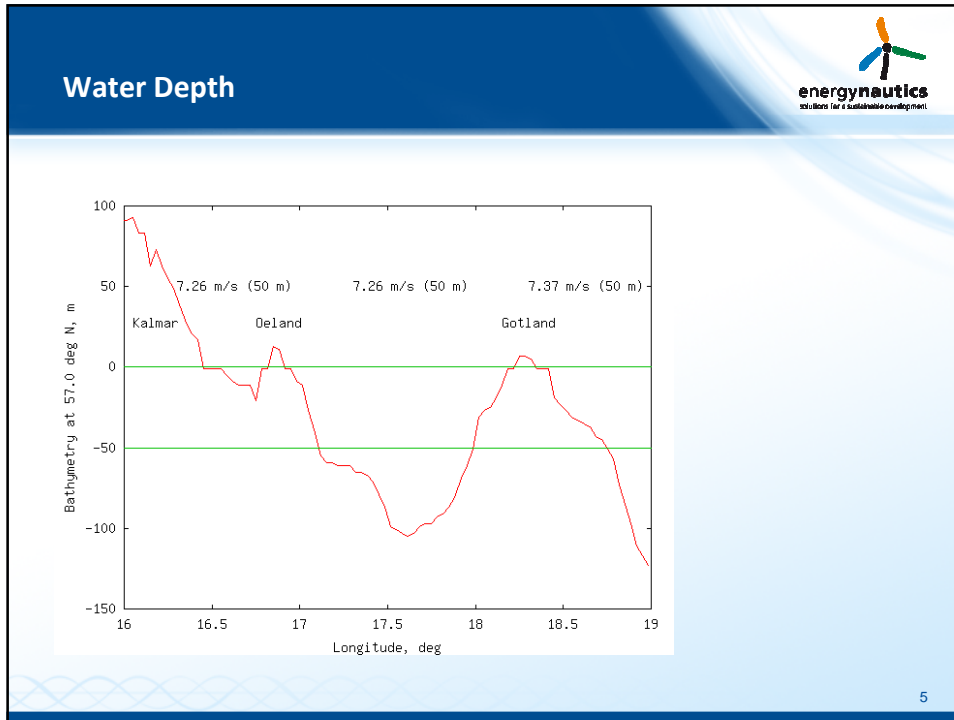

## Offshore Potential: Europe



	Germanischer Lloyd 1998	Present Study 2000
Annual potential	3.2 PWh	8.5 PWh
Area	EC only	Europe, Mahgreb
Wind speed at elevation	60 m	50 m
Maximum water depth	-40 m	-50 m
Maximum distance to shore	30 km	-
Exclusion zones	various	50%
Installation capacity	6 MW/km <sup>2</sup>	3.7 MW/km <sup>2</sup>

  

**Germanischer Lloyd: Voluntary Observer Fleet**

other option: Wasp with data from on-shore

7

## European Offshore Resource Map

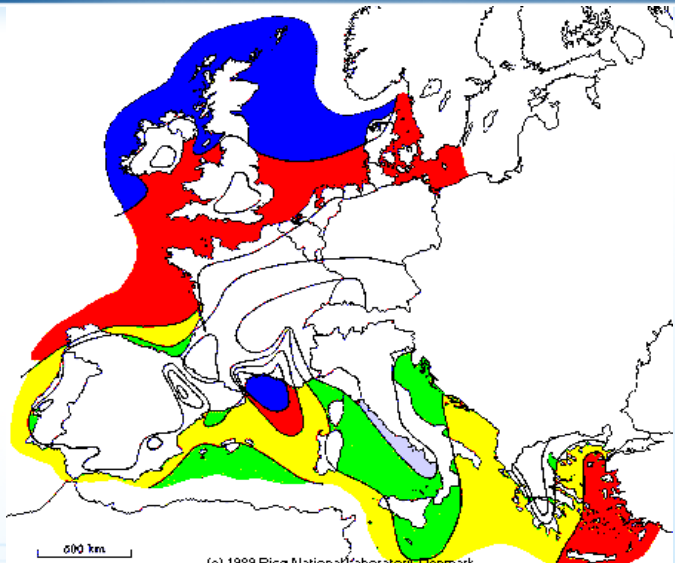

8

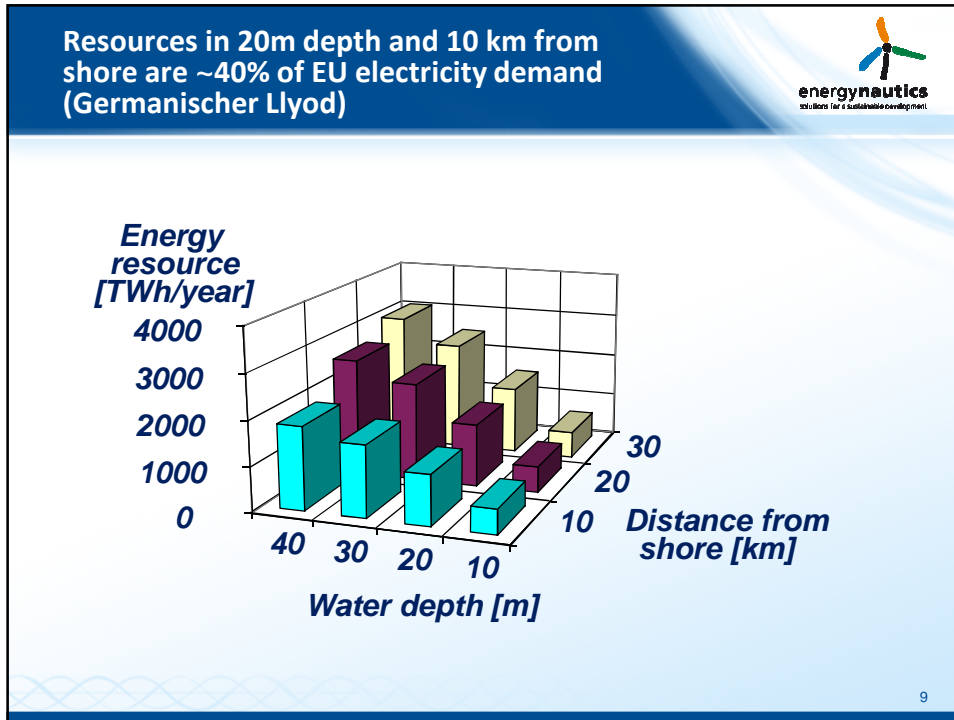

**Offshore Potential vs. Electricity Consumption**

	Max. Offshore Potential TWh/a	Annual Consumption TWh/a	Contribution
UK	986	321	307
Belgium	24	63.2	38
Netherlands	136	75.5	180
Germany	237	431.5	55
Denmark	550	32.2	1708

10

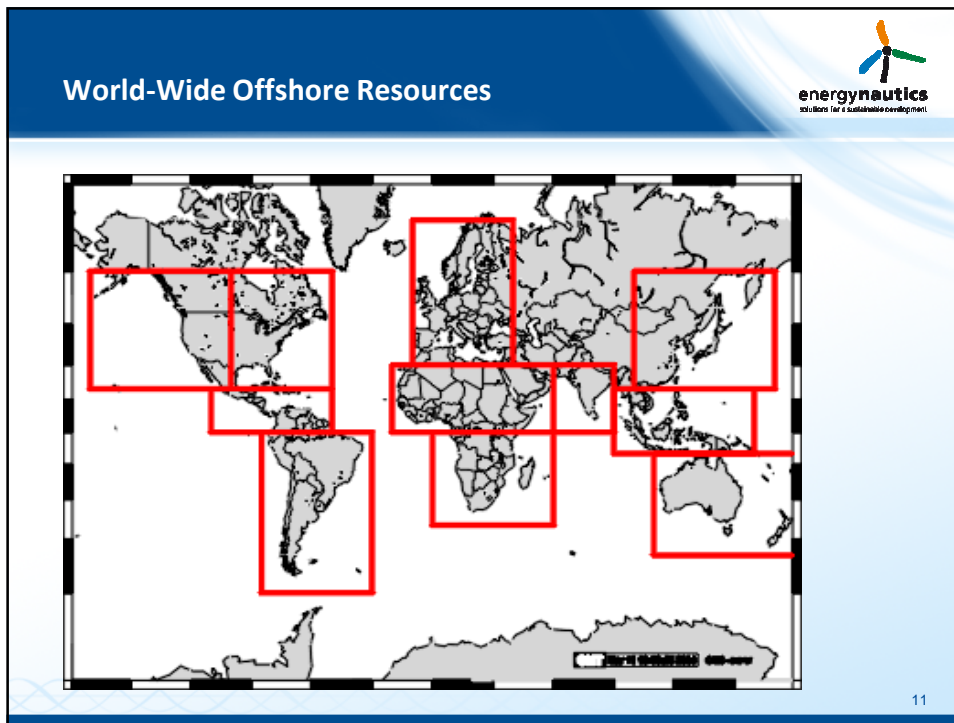

11

### World Offshore Potential

	Wind m/s	Area km <sup>2</sup>	Energy PWh/a	Intensity GWh/a km <sup>2</sup>
W North America	7.73	310	2.66	8.60
E North America	7.70	662	5.41	8.18
Central America	7.29	229	1.79	7.83
S America	8.54	484	5.66	11.17
Europe, Mahgreb	7.92	949	8.48	8.94
NW Africa, Arabia	4.67	354	0.79	2.23
S Africa	6.73	137	0.88	6.46
India	5.57	139	0.47	3.37
NE Asia	7.22	502	3.54	7.05
SE Asia	5.23	1112	3.20	2.87
Oceania	7.03	583	4.11	7.04
<b>Total</b>	<b>6.91</b>	<b>5461</b>	<b>36.99</b>	<b>6.74</b>

12



## Comparison

- **Current world-wide electricity production:**  
15 Peta Wh;
- **Offshore wind energy potential:**  
up-to 37 Peta Wh.

Peta =  $10^{15}$

13



## Offshore Advantages: Offshore Wind Conditions

- **Very low roughness length, but varying;**
- **Low turbulence intensity (depend on wave length);  
but wake effects within a wind farm are more pronounced;**
- **Low wind shear means lower hub height;**

14

## Disadvantages



- Extreme Waves;
- Maintenance;
- (Pack) Ice in the Water;
- High salt content in the air -> cooling, corrosion;
- Difficult environment to built;
- Tower resonance frequency influenced by waves;

15

## Costs Onshore

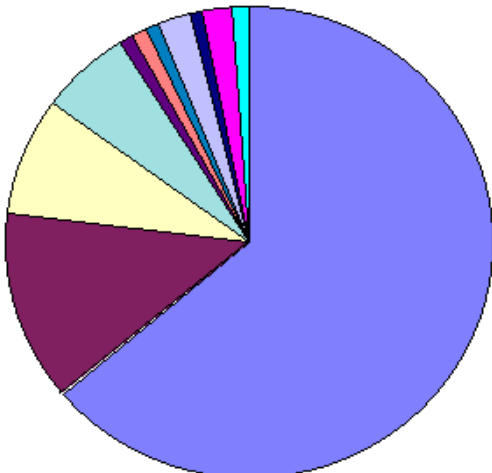
Wind turbines	(64% of total cost)
Civil works	(13%)
Electrical infrastructure	(8%)
Grid connection	(6%)
Project management	(1%)
Installation	(1%)
Insurance	(1%)
Legal costs	(2%)
Bank fees	(1%)
Interest during construction	(2%)
Development costs	(1%)

16

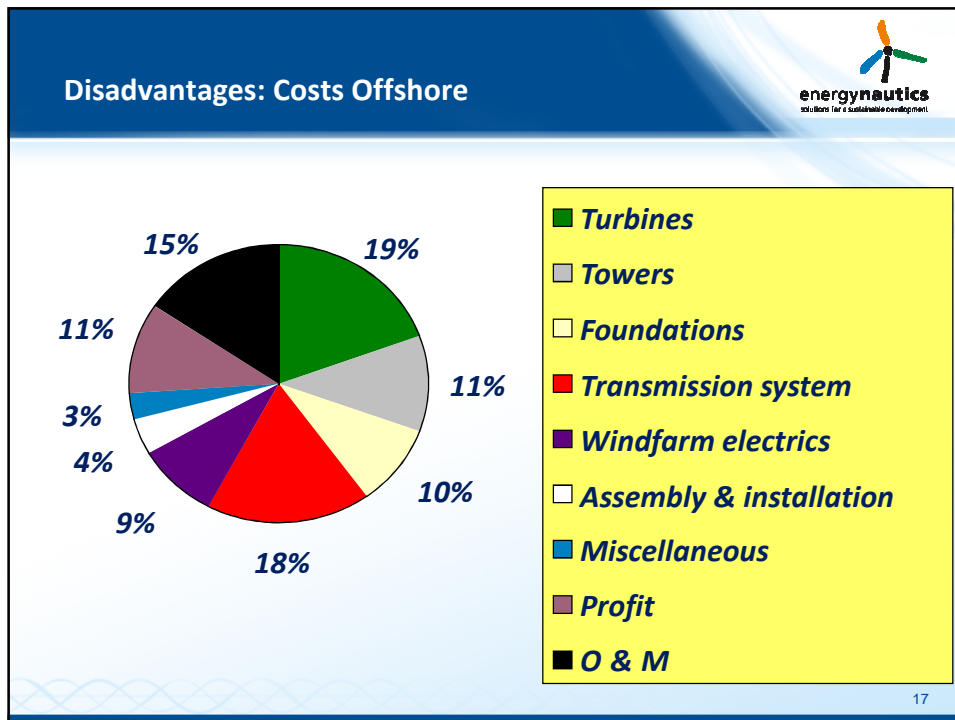

### Selected Existing and Planned Offshore Wind Farms (1/2)

Name, Country	Start	Turbines Rotor/kW	Total Capacity	Distance to PCC [km]	Collector Voltage	OSS <sup>1</sup>	Transmission Voltage
<u>Utgrunden, Sweden</u>	2000	7*Enron Wind 70/1500	10.5 MW	8	AC, 20 kV	No	AC, 20 kV
<u>Blyth, United Kingdom</u>	2000	2*Vestas 66/2.000	4 MW	2	AC, 11 kV	No	AC, 11 kV
<u>Middelgrunden, Denmark</u>	2001	20*Bonus 76/2.000	40 MW	4	AC, 30 kV	No	AC, 30 kV
<u>Yttre Stengrund, Sweden</u>	2001	5*NEG-Micon 72/2000	10 MW	6	AC, 20 kV	No	AC, 20 kV
<u>Horns Rev, Denmark</u>	2002	80*Vestas 80/2.000	160 MW	19+33 <sup>2</sup>	AC, 36 kV	Yes	AC, 150 kV
<u>Palludan Flak, Samsø, Denmark</u>	2003	10*82,4/2300 Bonus	23 MW	5	AC, 30 kV	No	AC, 30 kV
<u>Nysted, Lolland-Denmark</u>	2003	72*Bonus 82/2300	165.6 MW	10	AC, 33 kV	Yes	AC, 132 kV
<u>Arklow Bank, Irish Sea-Ireland</u>	2003	7*GEW 104/3600	25 MW	10	AC, 38 kV	No	AC, 38 kV
<u>North Hoyle, UK</u>	2003	30*Vestas 80/2000	60 MW	10	AC, 33kV	No	AC, 33 kV

### Selected Existing and Planned Offshore Wind Farms (2/2)



**energynautics**  
solutions for a sustainable development.

Name, Country	Start	Turbines Rotor/kW	Total Capacity	Distance to PCC [km]	Collector Voltage	OSS <sup>1</sup>	Transmission Voltage
Scroby Sands, Norfolk-UK	2004	30* Vestas 80/2000	60 MW	4	AC, 33 kV	No	AC, 33 kV
Kentish Flat, UK	2005	30* Vestas 90/3000	90 MW	9	AC, 33 kV	No	AC, 33 kV
Barrow, UK	2006	30* Vestas 90/3000	90 MW	27+3 <sup>3</sup>	AC, 33 kV	Yes	AC, 132 kV
Burbo Bank, UK	2007	25* Siemens 107/3600	90 MW	6,5	AC, 36 kV	No	AC, 36 kV
Lillgrund, Sweden	2007	48x Siemens 93/2300	110 MW	7+2 <sup>4</sup>	AC, 33 kV	Yes	AC, 138 kV
Q7, NL	2008	60* Vestas 80/2000	120 MW	23	AC, 22 kV	Yes	AC, 150 kV
Horns Rev II, Denmark	2009	91x Siemens 93/2300	215 MW	45+5 <sup>5</sup>	AC, 36 kV	Yes	AC, 170 kV
Test field Alpha Ventus, Germany	2009	6x5000 Repower, 6x5000 Multibrid	60 MW	66	AC, 30 kV	Yes	AC, 110 kV
Bard Offshore 1, Germany	est. 2013	80* Bard 122/5000	400 MW	128+75 <sup>6</sup>	AC, 33 kV	Yes	33 kV transformed to 154 kV AC, than ±150 kV DC for 203 km to PCC

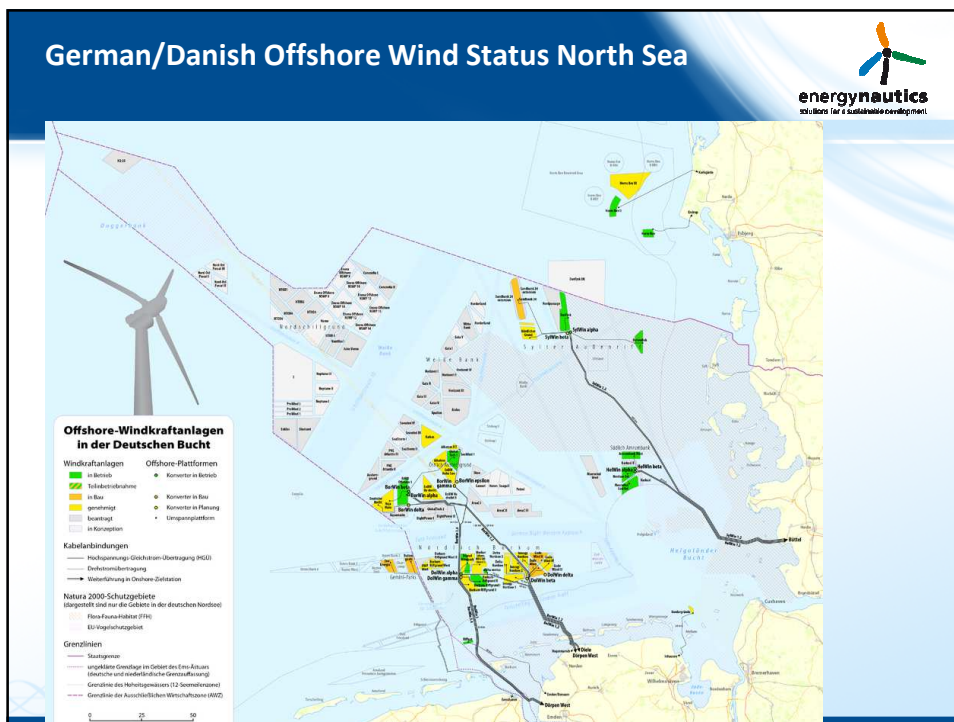

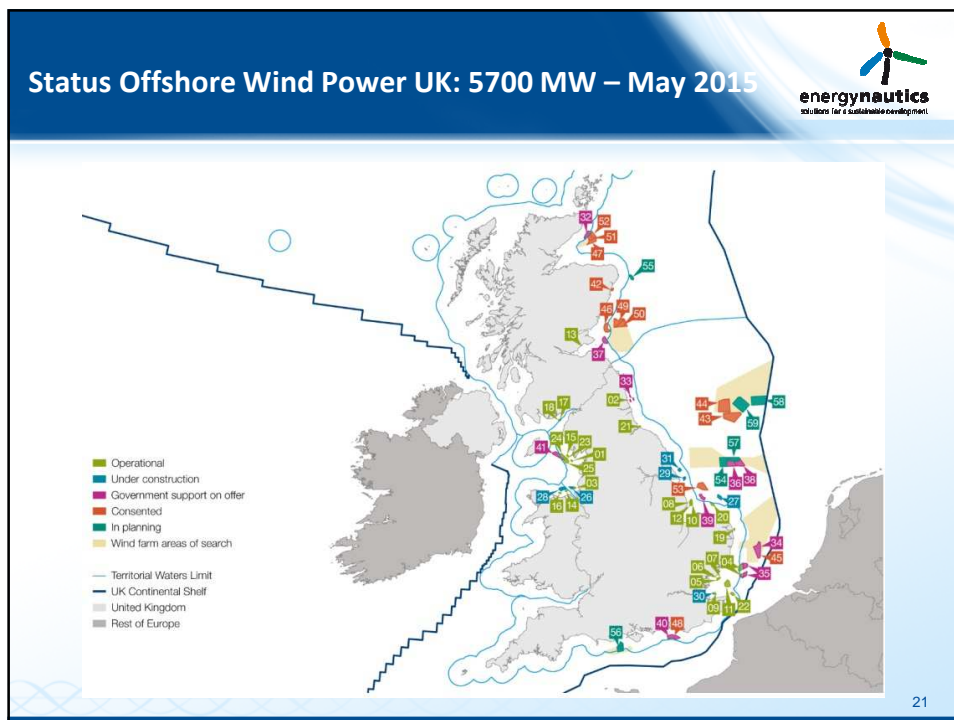

### Prognoses World-wide

- **Very optimistic: 4,000 MW per year from 2016/17;**
- **More sceptical: 2,000 MW per year from 2016/17;**
- **Critics: To expensive!**

22

**Offshore Wind Farm: Vindeby**



**energynautics**  
solutions for a sustainable development

23

**Vindeby**



**energynautics**  
solutions for a sustainable development

24

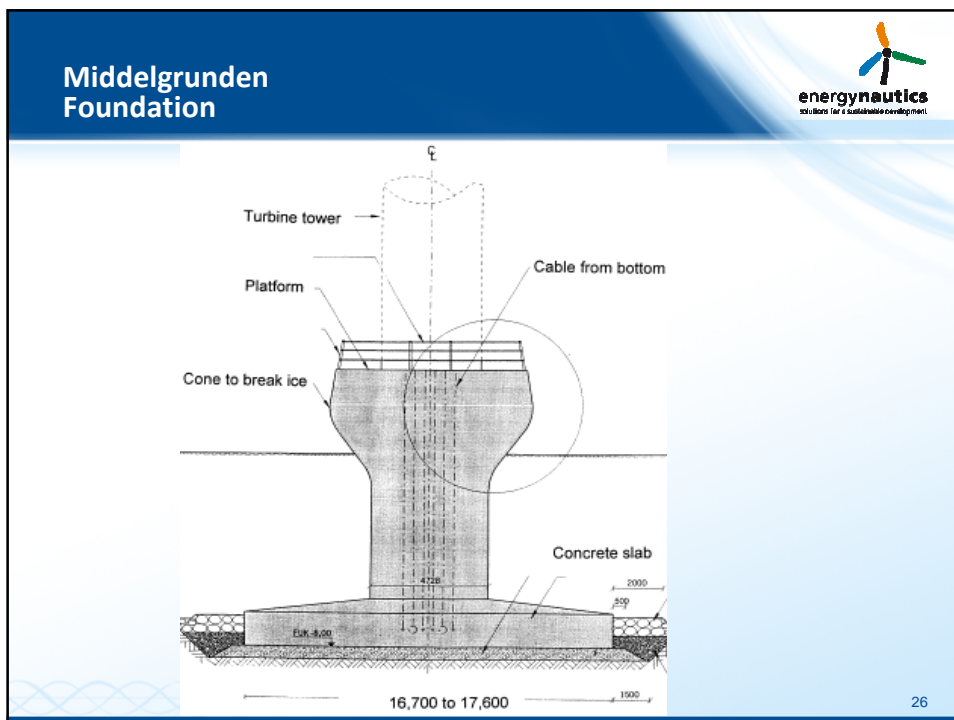
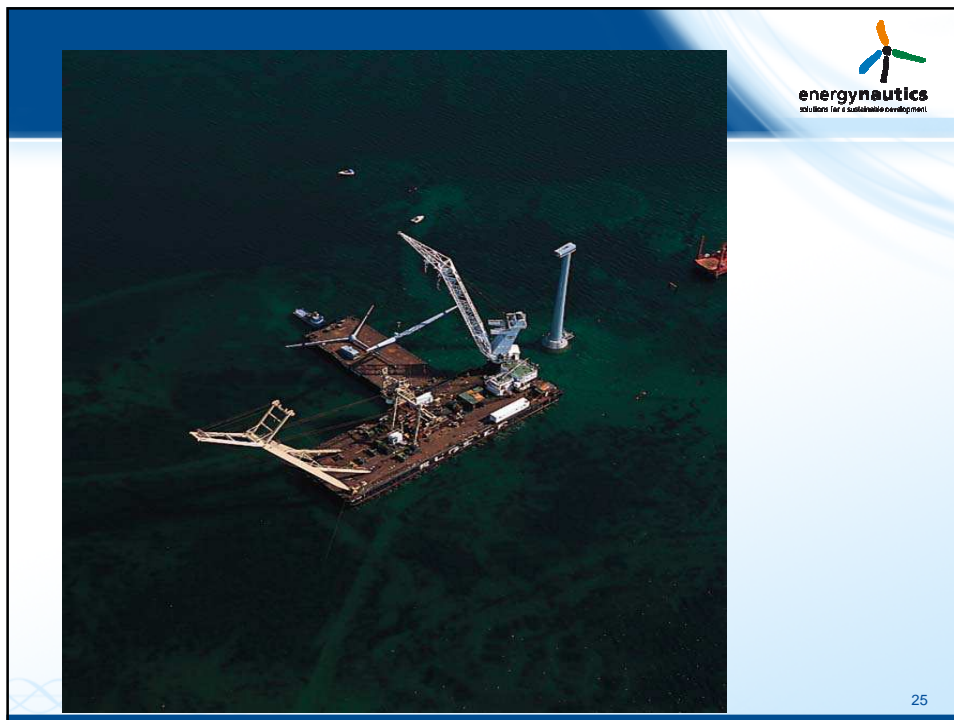

## Gravitation Foundation



energynautics  
solutions for a sustainable development

- As the name indicates, the gravity foundation relies on gravity to keep the turbine in an upright position;
- The caisson foundations are usually built in dry dock near the sites using armed concrete and are floated to the final destination before being filled with sand and gravel to achieve the necessary weight.

27

## Disadvantages of Concrete



energynautics  
solutions for a sustainable development

- The cost of the completed concrete foundation is approximately proportional with the water depth squared - the quadratic rule. (10 meter water depths, foundation ~ 1050 metric tones);
- Concrete foundation tend to become to heavy and expensive to install at water depths above 10 meters.

28

**Ice**



- Foundations which might experience solid ice should be formed conical to act as breakers for pack ice.

29

**Middelgrunden**



30

## Middelgrunden Data



energynautics  
solutions for a sustainable development

- 20 wind turbines (Bonus)
- Rated power 2 MW/400 kW each;
- Active stall power control;
- Hub height: 64 m;
- Rotor diameter: 76 m;
- Rotational speed 17/11 RPM
- Distance between neighbouring turbines: 183 m
- Water depth 5-10 m

31

## Middelgrunden Background



energynautics  
solutions for a sustainable development

- Expected annual electricity production:  
81 million kWh = electricity consumption  
of 20.000 Danish households;
- The wind farm is owned and operated by the  
Middelgrunden Wind Co-operative with 10,000  
members, and the energy distribution company  
Københavns Energi.

32



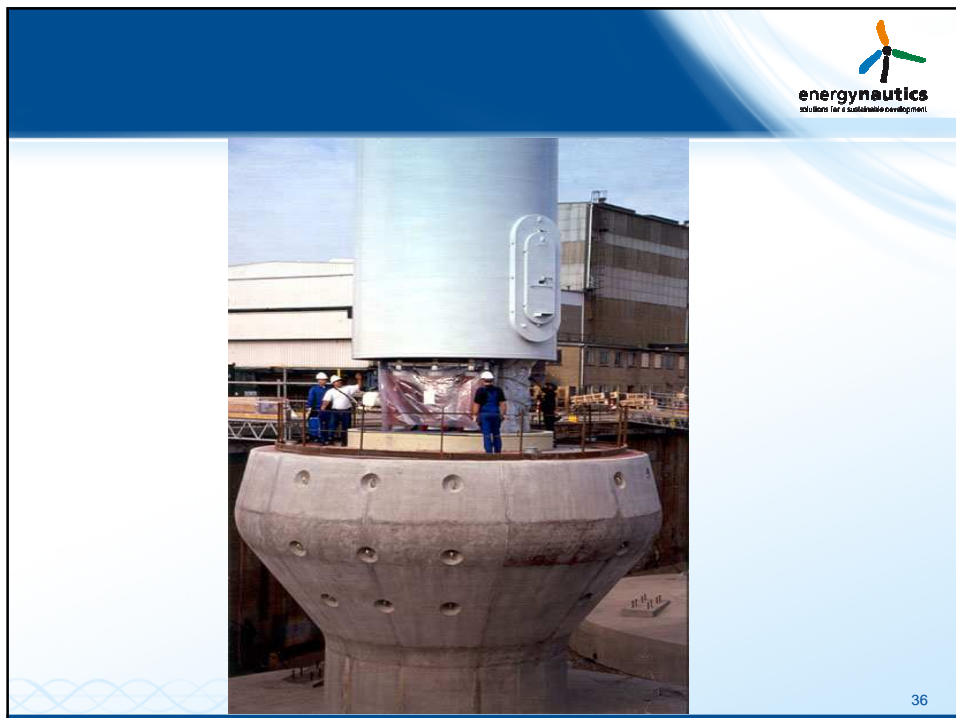
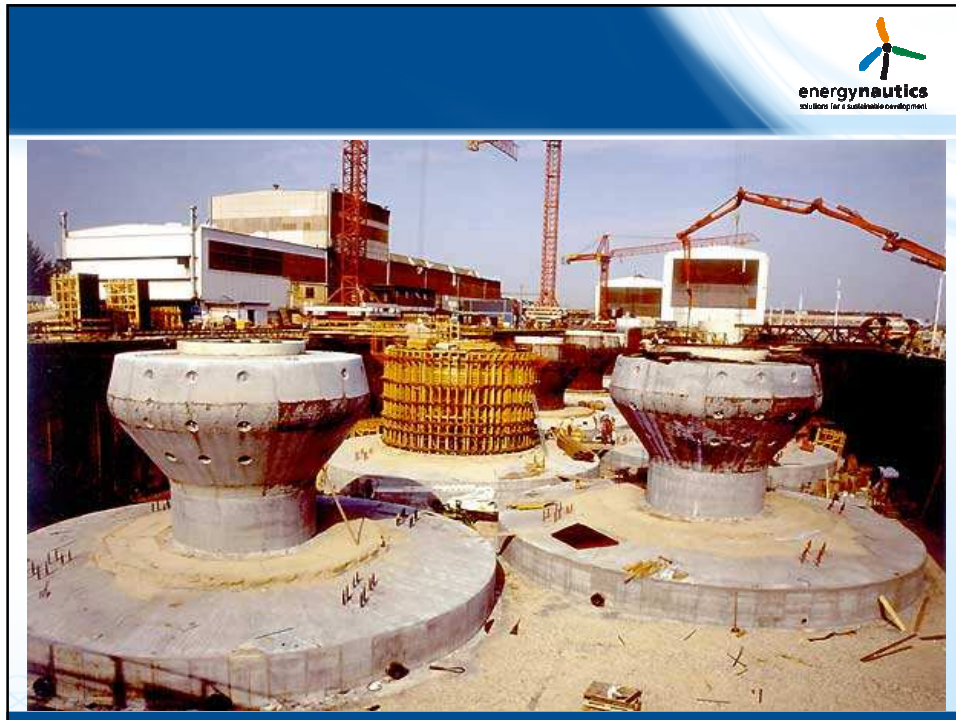

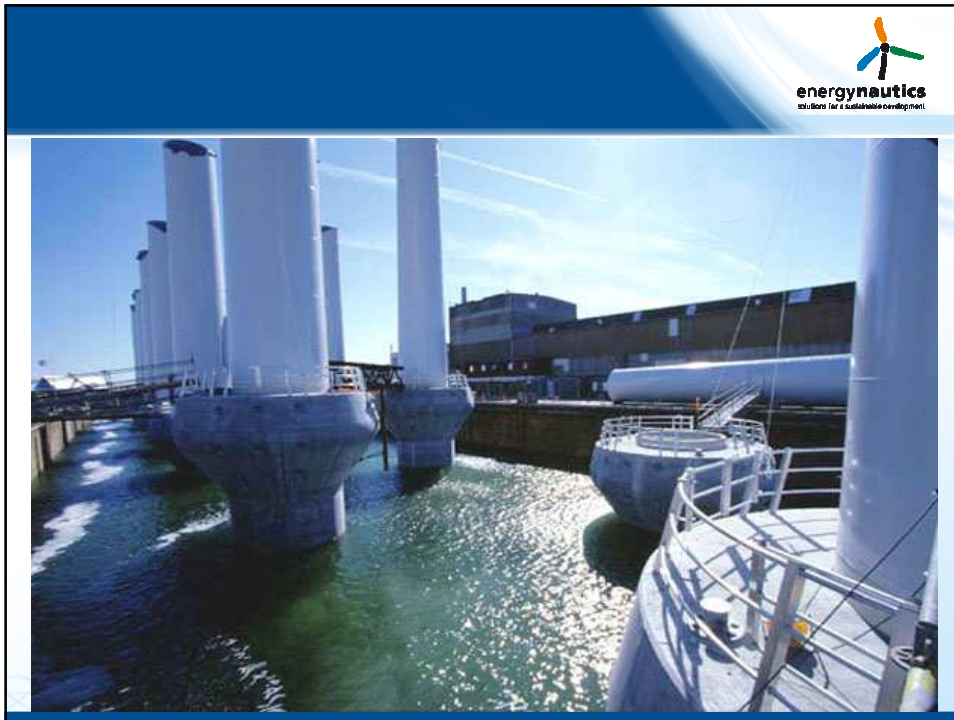





## Mono Pile

**Steel cheaper than concrete**

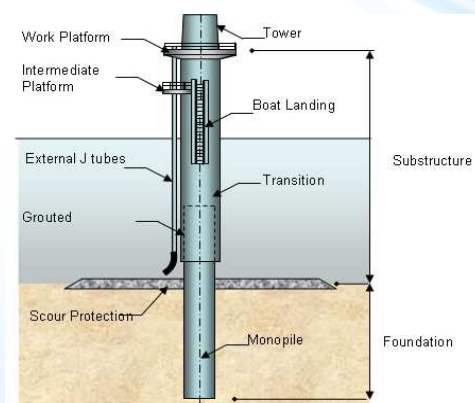
**The mono pile foundation consists of a steel pile with a diameter of between 3.5 and 4.5 metres. The pile is driven some 10 to 20 metres into the seabed depending on the type of underground.**



## Mono Pile



energynautics  
solutions for a sustainable development

- Steel cheaper than concrete;
- The mono pile foundation consists of a steel pile with a diameter of between 3.5 and 4.5 meters. The pile is driven some 10 to 20 meters into the seabed depending on the type of underground.

41

## Mono Pile II



energynautics  
solutions for a sustainable development

- An important advantage of the mono pile foundation is that no preparations of the seabed are necessary;
- But it requires heavy duty equipment.

42

## Bockstigen, Sweden



- The mono pile foundation technique at Gotland involved drilling a hole of 8 to 10 meters depth for each of the five turbines;
- Each steel pile is slotted into the solid rock;
- The whole operation took about 35 days under average Baltic weather conditions.

43

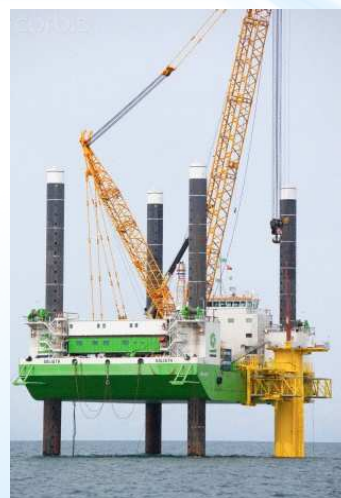
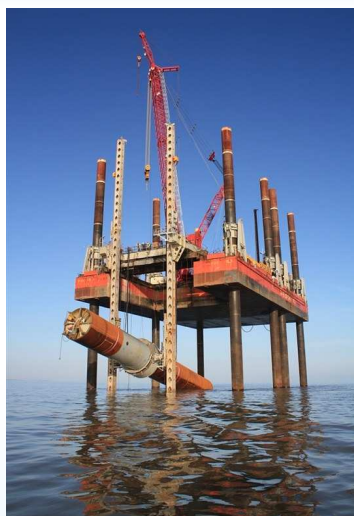



### Utgrunden/ Sweden: Mono Pile

- **Hammered into the ground;**
- **Weight of hammer 500 tons;**
- **1 hammer blow per sec;**
- **Time per foundation: 4 hours (~ 10 - 20 meters in the ground)**

46

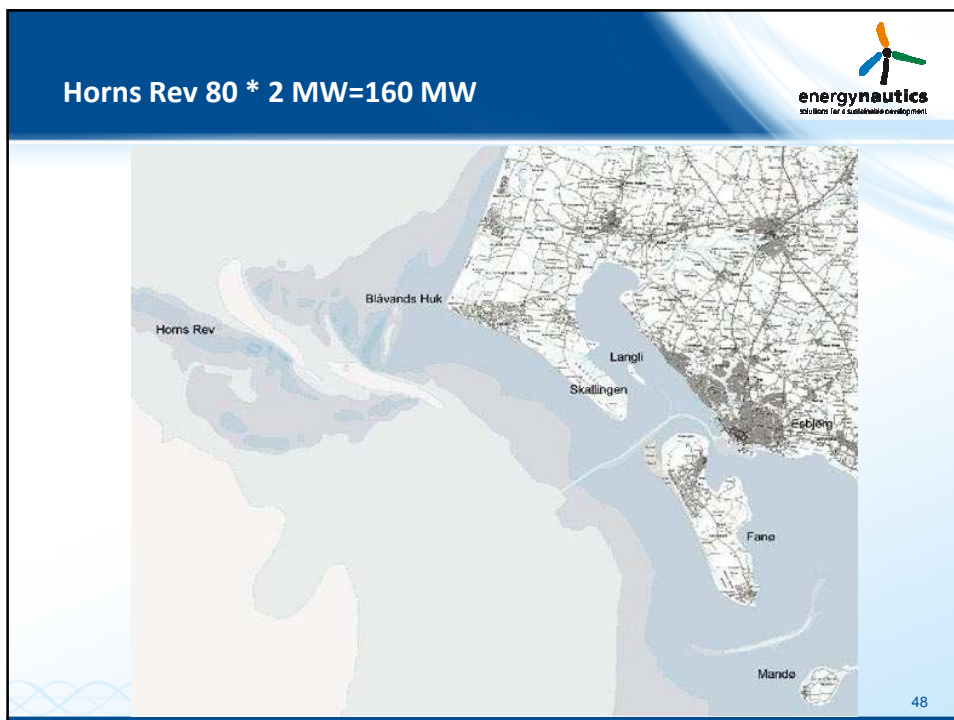

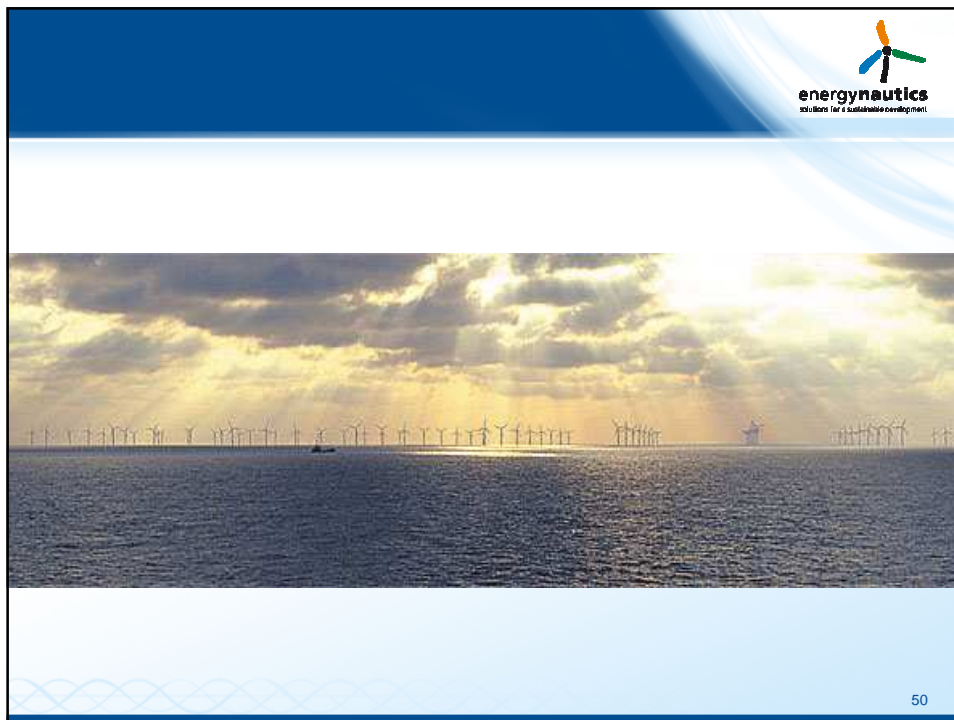
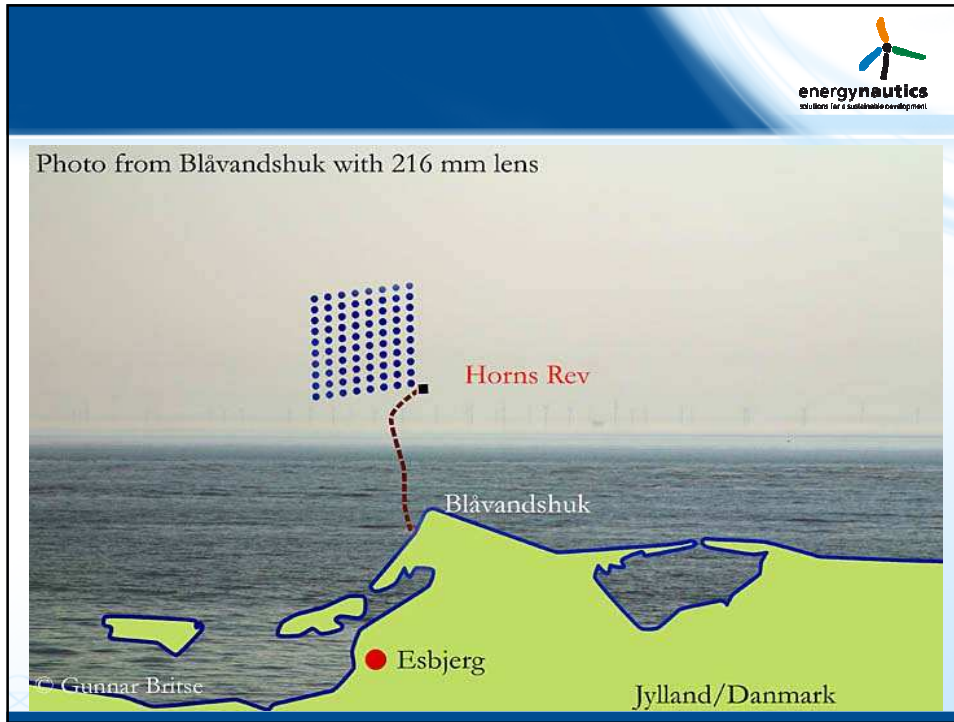



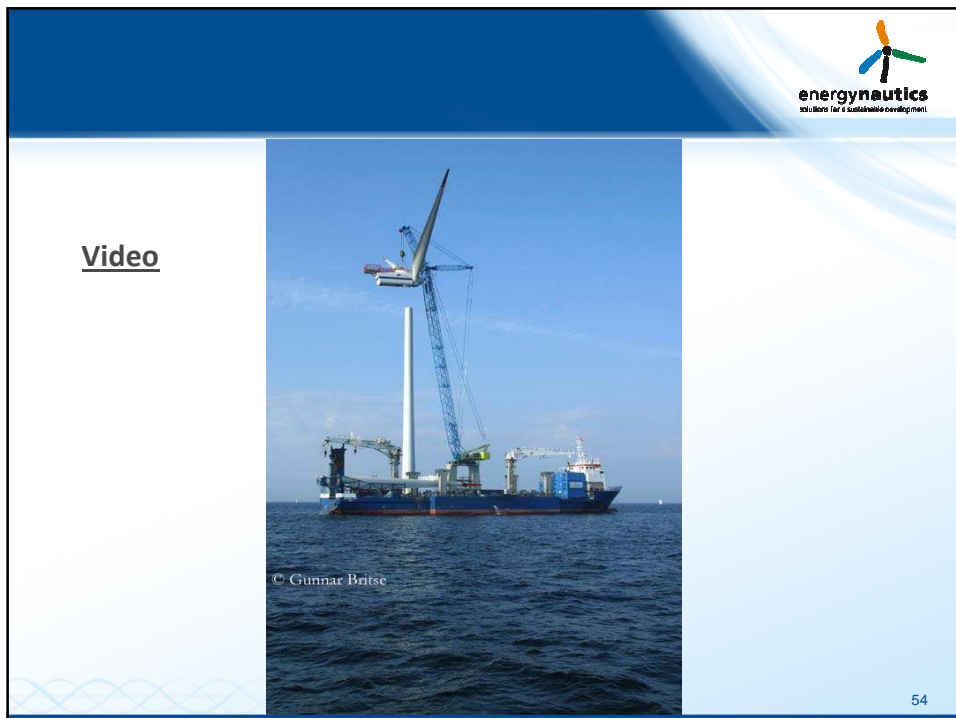

**Press Release May 2004  
Technical problems at Horns Rev**



For some time there have been technical problems with the wind turbines at Horns Rev. In autumn 2003, problems arose with the transformers of the wind turbines and later it has turned out that a large number of generators have production defects.

Operation of the wind farm is not satisfactory because of the problems. Vestas has acknowledged the problems and is making a great effort to make the wind turbines work satisfactorily.

The harsh conditions at the North Sea have impeded work and that is why Vestas considers whether it will be appropriate to dismantle all nacelles and bring them ashore to repair them under optimum conditions. The aim is to carry through that operation during this summer to bring all wind turbines in working order next autumn.

55

**The “DOWNVInD” Project**



“DOWNVInD” “Distant Offshore Windfarms with No Visual Impact in Deepwater”  
Europe's largest Renewable Energy Research and Technology Development Programme

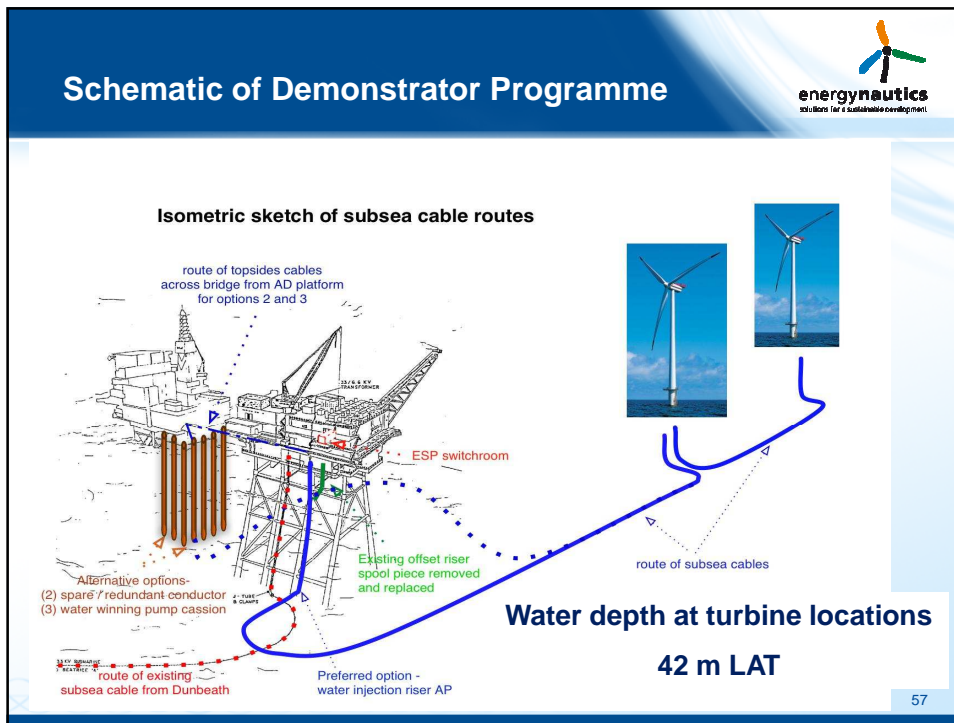



### Overview Wind Turbine Foundation

energynautics  
solutions for a sustainable development.

Foundation Type	Height (m)	Power (MW)
Monopile	0-30m	1-2 MW
Jacket/Tripod	25-50m	2-5 MW
Floating Structures (TLP, Semi-Sub, Spar)	>50m	5-10MW
Floating Structures (Spar)	>120m	5-10MW

### Tripod Foundation

energynautics  
solutions for a sustainable development.

62

## Tripod Foundation



- The tripod foundation draws on the experiences with light weight and cost efficient three-legged steel jackets for marginal offshore fields in the oil industry.
- The three piles are driven 10 to 20 meters into the seabed depending on soil conditions and ice loads.

63

## 5 MW BARD Nearshore Hooksiel



64





enerdynautics  
services for a sustainable development



Video

Next Steps ...



enerdynautics  
services for a sustainable development



## 2 Bladed Turbines for Offshore



An aerial photograph of a 2-bladed offshore wind turbine. The turbine is white with a green and yellow rotor hub. A red helicopter is perched on the hub. The turbine is situated in the middle of a vast, blue ocean under a clear sky.

## Tripod Foundation II



- The advantage of the three-legged model is that it is suitable for larger water depths (North sea). At the same time only a minimum of preparations are required at the site before installation.

70

## Floating Concepts



energynautics  
solutions for a sustainable development.

### Floating Wind Turbine Concepts

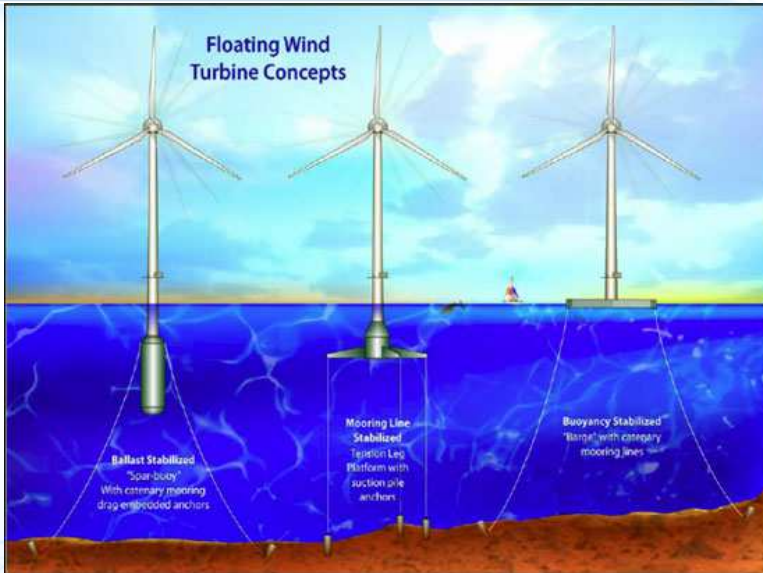

**Ballast Stabilized**  
"Spar-buoy"  
With catenary mooring  
drag-embedded anchors

**Mooring Line Stabilized**  
Tension Leg  
Platform with  
suction pile  
anchors

**Buoyancy Stabilized**  
"Barge" with catenary  
mooring lines

71

## First Demonstration Project Hywind - Norway



energynautics  
solutions for a sustainable development.

### Floating turbine

Norway's Statoil Hydro will tow out the world's first floating turbine for a two-year test period.

- Combines technology from Statoil's wind, oil and gas industries
- Around \$80 million (56.7 million euros) invested in the project
- Connected to mainland grids via cables across the seabed



**Hywind**



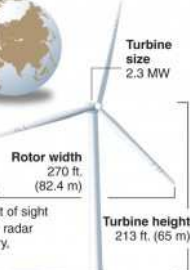

Norwegian Sea SWE. NORWAY FIN.



**Turbine size**  
2.3 MW

**Rotor width**  
270 ft. (82.4 m)

**Turbine height**  
213 ft. (65 m)

**Benefits**

- Keeps offshore wind farms out of sight
- Less interference with military radar operations, the shipping industry, fisheries, bird life and tourism

**Three mooring lines to be attached to seabed**

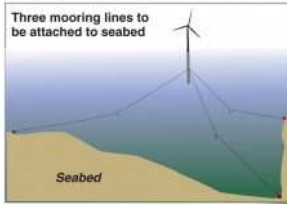

Sea depth 394-2,297 ft. (120-700 m)

Seabed

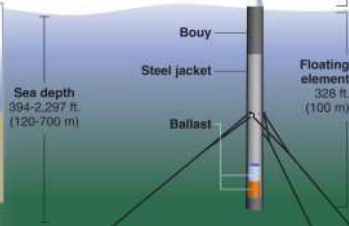

**Bouy**

**Steel jacket**

**Ballast**

**Floating element**  
328 ft. (100 m)

Source: Statoil Hydro. Graphic: Scott Bell, Eoil Polli. © 2009 MCT



## Turbine Technology



- Larger turbines
- Two bladed? (designed for a site)
- Higher tip speed ratio
- Reduced Maintenance
- Multibrid System ...

## Grid Connection



energynautics  
solutions for a sustainable development

- HVAC - seems to be the most costs effective solution for connection shorter than 20 km;
- HVDC (High Voltage Direct Current ) - a very interesting solution

75

## HVAC



energynautics  
solutions for a sustainable development

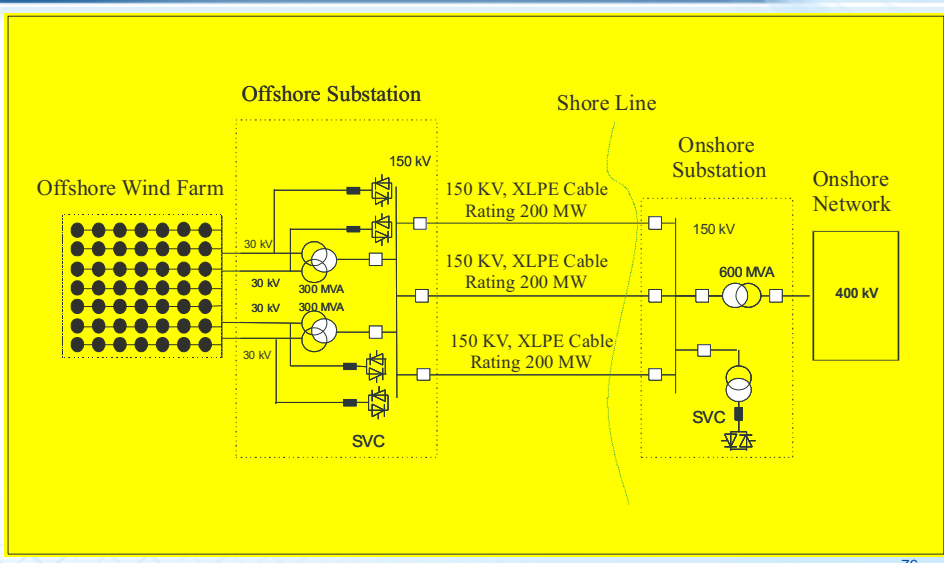

The diagram illustrates the HVAC system architecture. On the left, an Offshore Wind Farm is connected to an Offshore Substation. The substation features three 30 kV lines from the wind farm, each passing through a 300 MVA transformer to a 150 kV bus. An SVC (Static Var Compensator) is connected to this 150 kV bus. Three 150 kV, XLPE cables, each with a 200 MW rating, connect the offshore substation to an Onshore Substation. The Onshore Substation includes a 600 MVA transformer stepping down from 150 kV to a 400 kV bus, which is connected to the Onshore Network. An SVC is also connected to the 150 kV bus in the onshore substation.

76

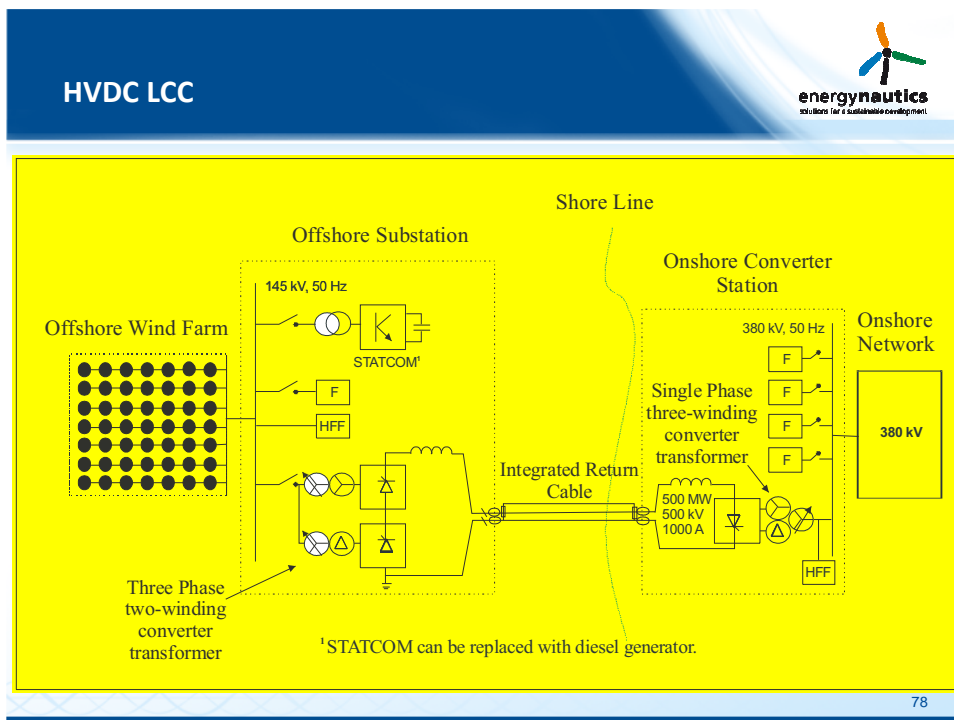
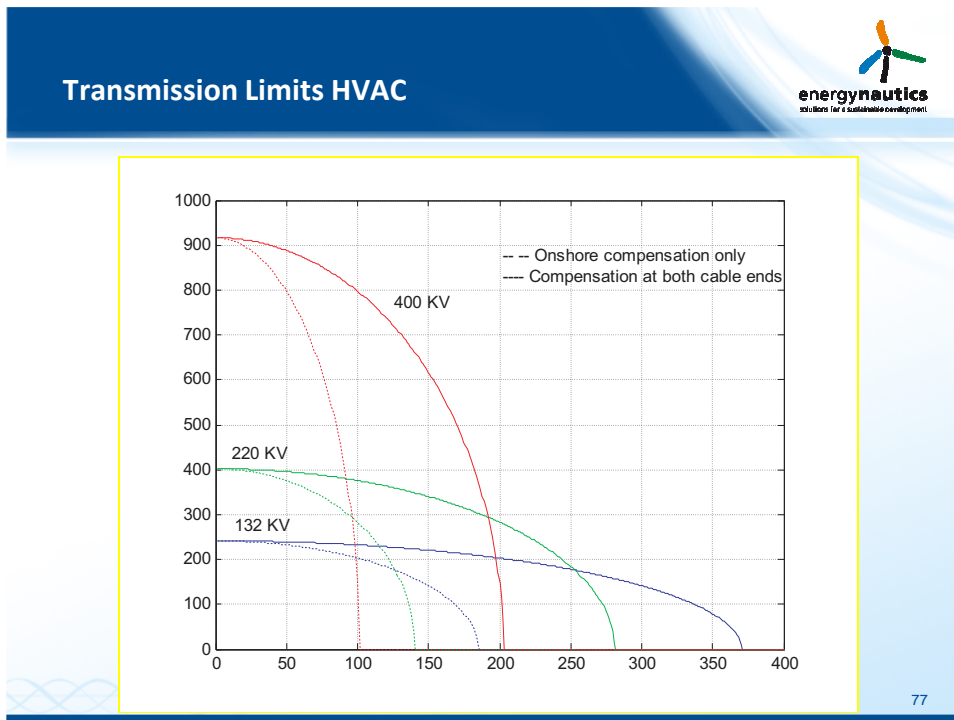

## HVDC VSC

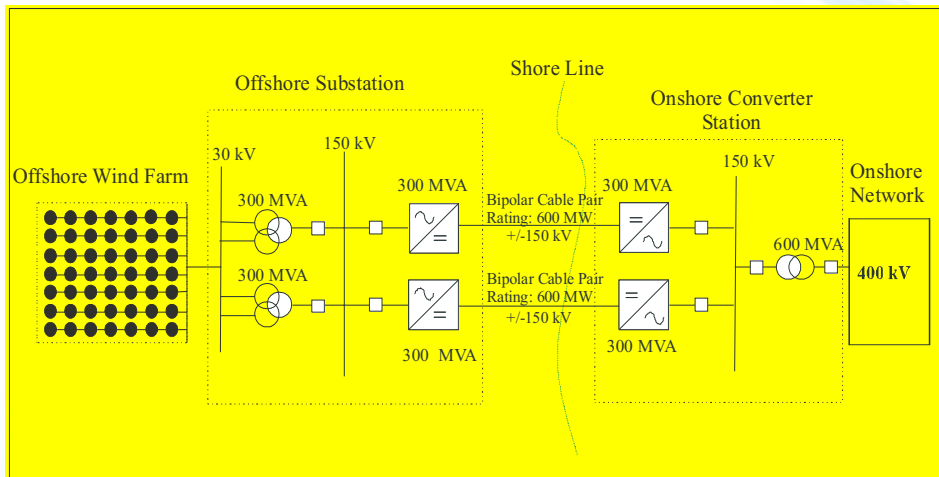

79

## Grid Connection II



- Inside large 120-150 MW wind parks it is likely that 30-33 kV connections will be used. In the middle of each park there will probably be a platform with a 30 to 150 kV transformer station.
- Connection to the mainland will be done using ~150 kV connections.

80

### energynautics solutions for a sustainable development

## Grid Connection III

- **Main problem: only one cable to the mainland, hence no backup;**
- **Only a few connection points for 200 - 1000 MW offshore wind parks, e.g. switched off nuclear power station.**

81

### energynautics solutions for a sustainable development

## 'Radial' clustered wind turbines connected to single hub

- **Simple control**
- **Relatively inexpensive**
- **Poorer reliability**
- **Switchgear more straightforward**

82

**'Single sided ring' clustered wind turbines connected to single hub**

**energynautics**  
solutions for a sustainable development

- Ring operated in open configuration
- More expense in cabling (run length plus loss of tapering)
- Greater security

83

**'Double sided ring' clustered wind turbines connected to single hub**

**energynautics**  
solutions for a sustainable development

- Ring operated in open configuration
- More expense in cabling (possibility of partially rating cables)
- Greater security
- Upper limit on cable ratings a possible constraint

84

### 'Star' clustered wind turbines connected to single hub

**energynautics**  
solutions for a sustainable development

- Reduced cables ratings (and expense)
- Good security
- Good voltage regulation
- Switchgear arrangement more complex and expensive

85

### 'Multiple hub' arrangement with radial clustered wind turbines

**energynautics**  
solutions for a sustainable development

- Lower losses through higher voltage collection
- More expensive ENV cables?
- Multiple hubs provides greater security but more cost

86



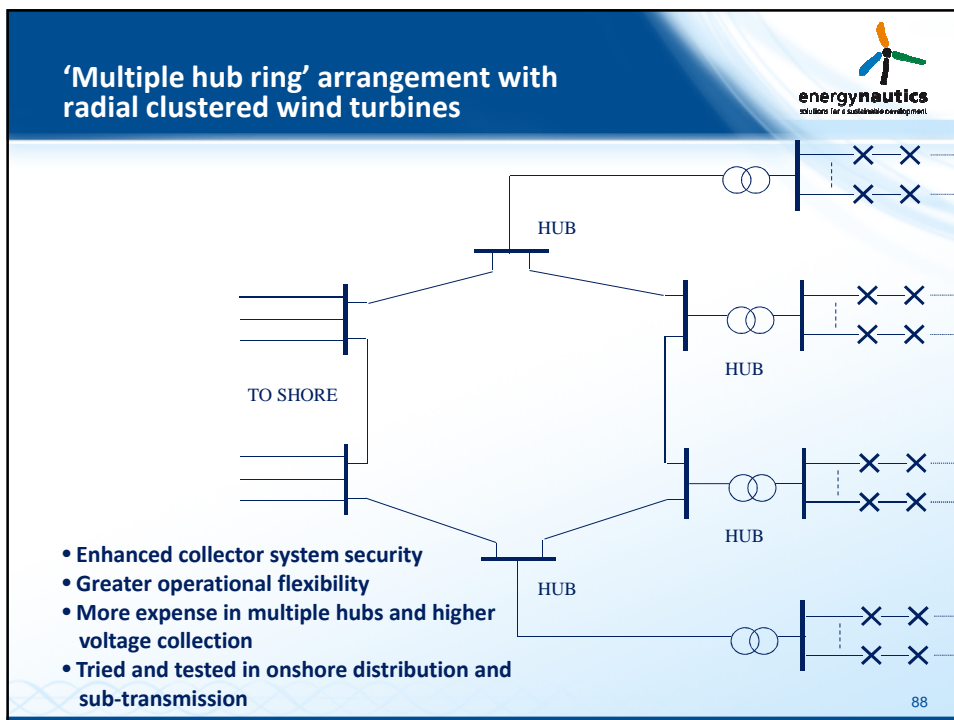

87

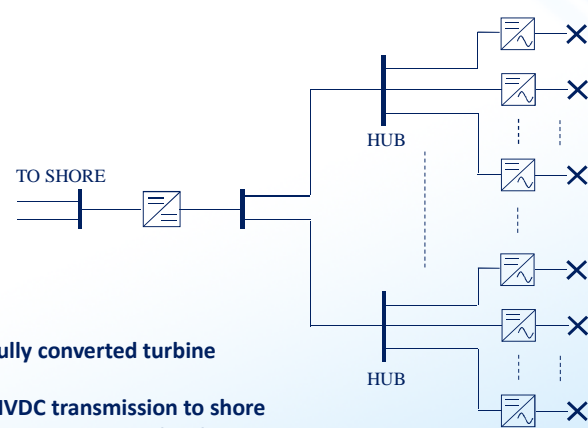

88

### DC collector system arrangement with radial clustered wind turbines





- Fits with future fully converted turbine generators
- Less expense in HVDC transmission to shore
- Costs within collector system unclear?
- More costly DC switchgear

89

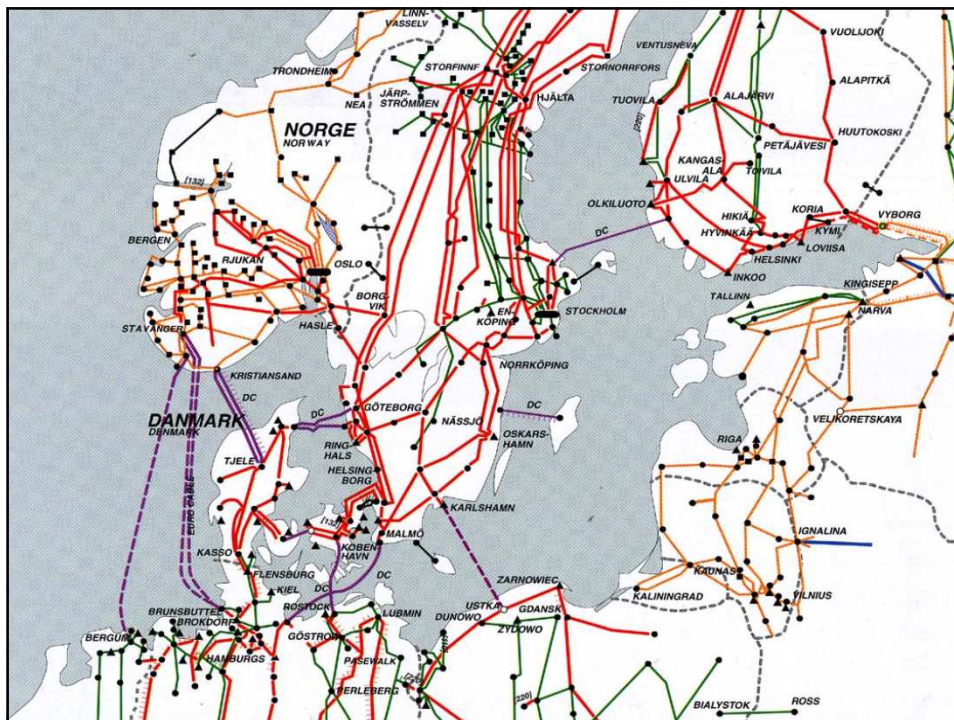



## Within the wind farm: cable installation

- **cable failure could take several months to repair:**
  - existing data: 0.32 failures/100 km/year
  - 50% of failures caused by anchors and fishing gear
- **no need for burial within the wind farm lay from barge:**
  - cheaper installation
  - quicker repair

91



## Offshore electrical systems compared to onshore

- larger arrays, larger machines;
- longer fault repair times;
- less frequent scheduled maintenance;
- further to network connection points;
- more aggressive environment;
- less space available for equipment;
- more freedom for cable routes

92

## Maintenance



energynautics  
solutions for a sustainable development

- **Very reliable equipment needed, as maintenance possibilities might depend on weather conditions (waves must be less than 3 meters);**
- **Yearly maintenance cycles or even better might be required;**
- **Helicopter landing platforms discussed.**

93

## Environmental Impact



energynautics  
solutions for a sustainable development

- **Birds: A three year offshore bird life study made at the Danish offshore wind farm Tunø Knob concluded that birds are not effected;**
- **Fish/ Mussels etc. similar conclusion, further studies are underway;**
- **Fishermen are afraid that fish escape ...**

94

