



Skriftlig Tentamen

IE1204 Digital Design

2023-2024 **Med Lösningar**

Examiner/Examinator: Carl-Mikael Zetterling

Responsible teacher/Ansvarig lärare: Carl-Mikael Zetterling, 08-790 4344

Swedish/Svenska:

Tentamenstexten ska lämnas in när lösningarna lämnas in.

Inga tillåtna hjälpmedel utom linjal.

Examen består av två delar:

Del 1 har 16 uppgifter med max 1 poäng per uppgift som ska besvaras på ”Answer Form”.

Del 2 har 4 uppgifter med max 4 poäng per uppgift som ska besvaras på separat papper.

Lämna in båda delar samtidigt. Disponera tiden själv mellan delarna.

Uppgifterna är inte ordnade efter svårighetsgrad.

Om slutsumman av tentan har halvpöäng avrundas det uppåt.

Totalt max 32 poäng på tentamen.

För godkänt krävs

(minst 8 poäng på del 1) OCH (minst 16 poäng totalt)

Fx om något villkor ej är uppfyllt med en poängs marginal.

Det betyder att

För E krävs minst 16 poäng totalt och minst 8 på del 1.

För Fx krävs 16 poäng totalt och minst 7 på del 1

eller 15 poäng totalt och minst 8 på del 1.

Betygskalan för tentamen förutsatt att studenten har minst 8 poäng från del 1.

0-15	16-18	19-21	22-24	25-27	28-31	32
F	E	D	C	B	A	A+

Resultat meddelas inom tre veckor.

Written Exam

IE1204 Digital Design

2023-2024 **With Solutions**

Examiner/Examinator: Carl-Mikael Zetterling

Responsible teacher/Ansvarig lärare: Carl-Mikael Zetterling, 08-790 4344

English:

The exam text should be handed in after the exam.

No aids allowed except ruler.

The exam consists of two parts:

Part 1 has 16 exercises for max 1 point per exercise to be answered on the “Answer Form”.

Part 2 has 4 exercises for max 4 points per exercise, to be answered on a separate paper.

Hand in both parts at the same time. Plan the time yourself between the parts.

The exercises are not in order of difficulty.

If the total sum of the exam has half points this will be rounded up.

Total max of 32 points on the exam.

To pass the exam requires

(at least 8 points from part 1) AND (at least 16 points in total)

Fx if any condition is not fulfilled by one point’s margin.

This means

For E, a minimum of 16 points in total and at least 8 in part 1 is required.

For Fx, 16 points are required in total and at least 7 on part 1

or 15 points in total and at least 8 in part 1.

Grades are given as follows provided the student has at least 8 points from part 1.

0-15	16-18	19-21	22-24	25-27	28-31	32
F	E	D	C	B	A	A+

The result will be announced within three weeks.

Del 1/Part 1, 1 point per exercise, fill in on “Answer Form”

1 Number Conversion

Swedish: Konvertera de positiva talen och utför beräkningen.
Svara med ett decimalt tal.

English: Convert the unsigned numbers and perform the calculation.
Answer with a decimal number.

$$Y = 100111_2 + 23_8 + 23_{10} + 23_{16} \\ = 39 + 19 + 23 + 35 = 116$$

2 Addition

Swedish: A och B är hexadecimala 8 bitars två-komplement kodade tal.
Beräkna A + B och svara med ett 8 bitars två-komplement hexadecimalt kodat tal.
Tänk på att du kan kontrollera dina beräkningar med decimala tal.

English: A and B are hexadecimal 8-bit binary (two's complement) numbers.
Calculate A + B and answer with an 8-bit binary (two's complement) hexadecimal number.
You can check your calculations using decimal numbers.

$$\begin{array}{r} A = 0x52 = 52_{16} \quad 01010010 \\ B = 0xA2 = A2_{16} \quad + \underline{10100010} \\ A + B \quad \quad \quad = 11110100 = 0xF4 \end{array}$$

or calculate directly from $0x52 + 0xA2$

3 Subtraction

Swedish: A och B är hexadecimala 8 bitars två-komplement kodade tal.
Beräkna A - B och svara med ett 8 bitars två-komplement hexadecimalt kodat tal.
Tänk på att du kan kontrollera dina beräkningar med decimala tal.

English: A and B are hexadecimal 8-bit binary (two's complement) numbers.
Calculate A - B and answer with an 8-bit binary (two's complement) hexadecimal number.
You can check your calculations using decimal numbers.

$$\begin{array}{r} A = 0x3A = 3A_{16} \quad \quad \quad 00111010 \\ B = 0x27 = 27_{16} \quad \quad = 00100111 \\ - B = \quad \quad \quad \quad \quad + \underline{11011001} \\ A - B \quad \quad \quad \quad \quad = 00010011 = 0x13 \end{array}$$

or calculate directly from $0x3A - 0x27$

4 Analysis of CMOS circuits

Swedish: Ta fram enklast möjliga booleska uttryck för CMOS-kretsen.

English: Derive the simplest possible Boolean expression for the CMOS circuit.

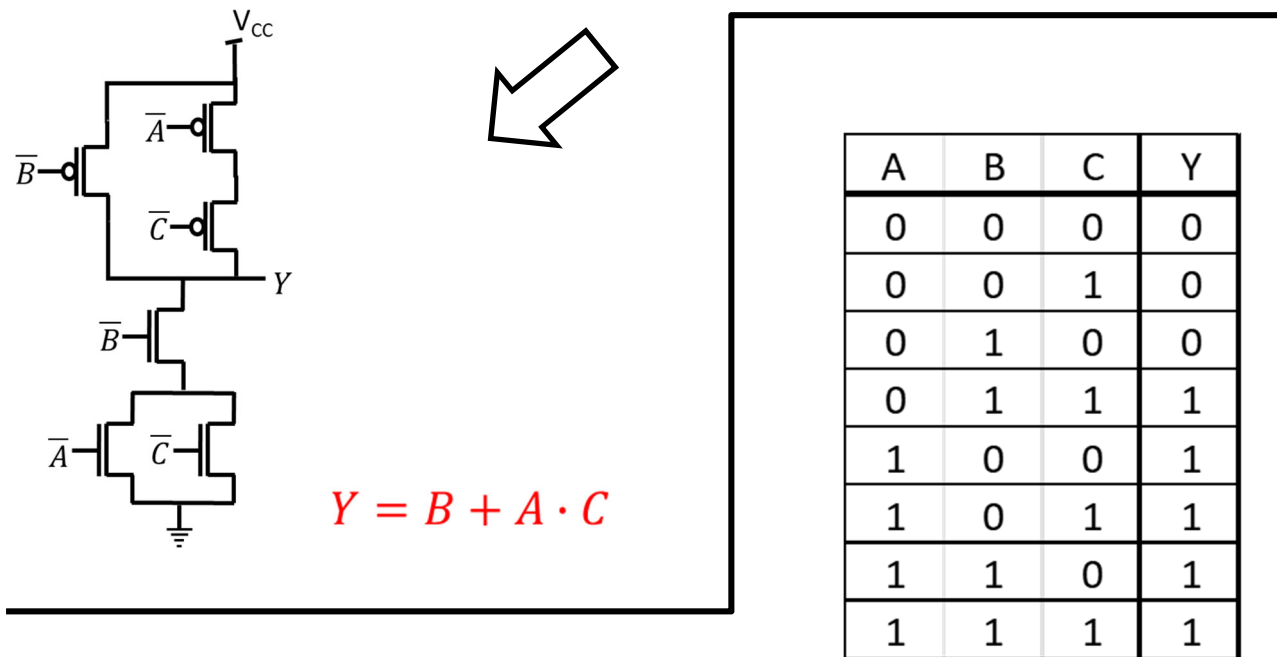

5 Design of CMOS circuits

Swedish: Bestäm vilken av CMOS-kretsarna som passar med sanningstabellen.

English: Determine which one of the CMOS circuits that matches the truth table.

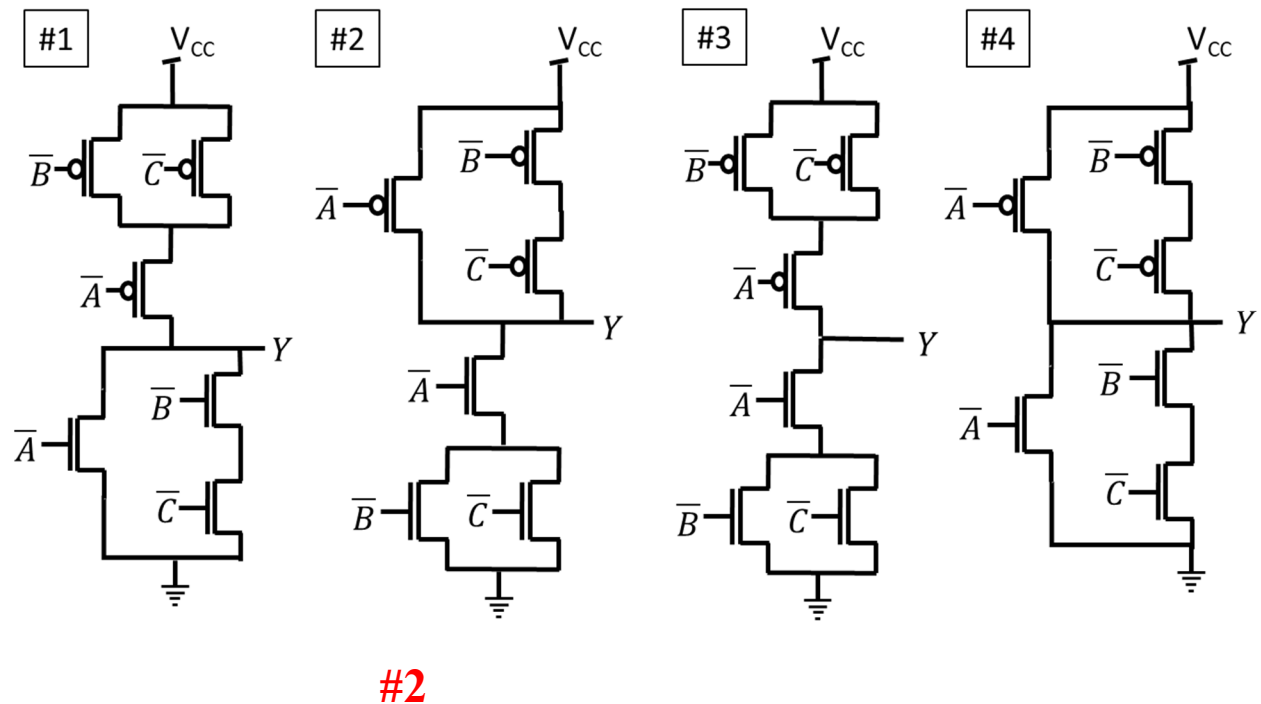

6 Analysis: MUX to K-map

Swedish: Fyll i K-Map från MUX-kopplingen.

Ta fram enklast möjliga booleska uttryck för Y från K-map. Välj PoS eller SoP.

English: Fill in the K-Map from the MUX circuit.

Derive simplest possible Boolean expression from the K-map. Select PoS or SoP.

Y	CD 00	CD 01	CD 11	CD 10
AB 00	1	1	1	1
AB 01	0	0	1	0
AB 11	0	1	0	0
AB 10	1	1	1	1

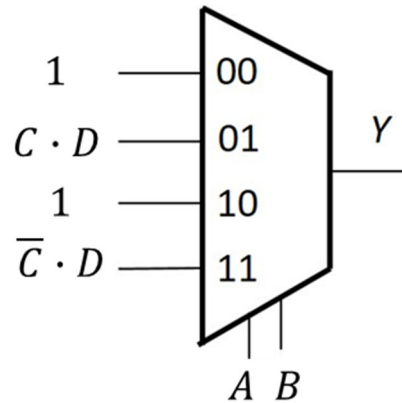

$$\bar{B} + \bar{A}CD + A\bar{C}D = (\bar{B} + D)(A + \bar{B} + C)(\bar{A} + \bar{B} + \bar{C})$$

7 Design: K-Map to MUX

Swedish: Använd en 4:1 MUX och valfria grindar eller 0 och 1 och gör en krets för K-map med CD som select-signaler.

English: Use a 4:1 MUX and any logic gates or 0 or 1 to draw a circuit for the K-map with CD as select signals.

Y	CD 00	CD 01	CD 11	CD 10
AB 00	1	1	0	1
AB 01	0	0	1	0
AB 11	1	1	0	0
AB 10	1	0	1	0

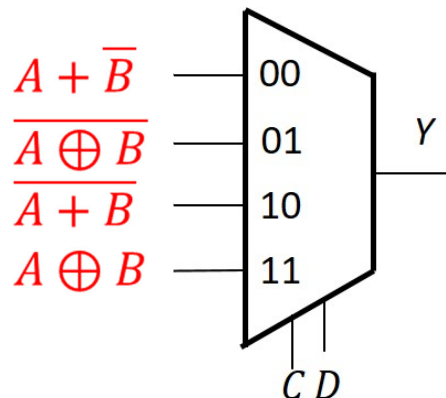

0.5 point deducted if third and fourth expressions are interchanged.

8 Timing diagram (Analysis)

Swedish: Rita tidsdiagram för kretsen i "Answer Form".

English: Draw the timing diagram for the circuit in the "Answer Form".

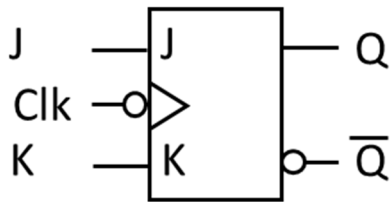

NOTE: negative edge

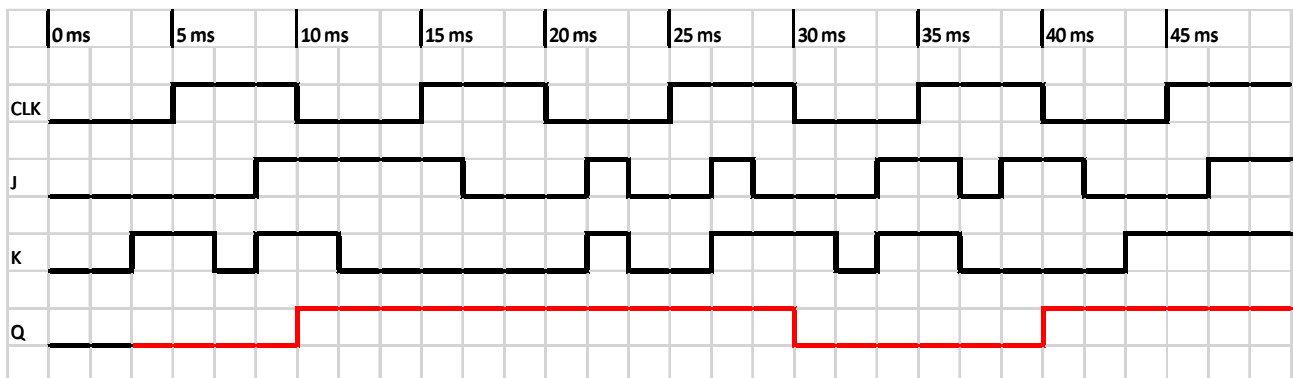

9 Timing diagram (Design)

Swedish: Vilken vippa eller latch ger tidsdiagrammet nedan?

English: Which flip-flop or latch has the timing diagram below?

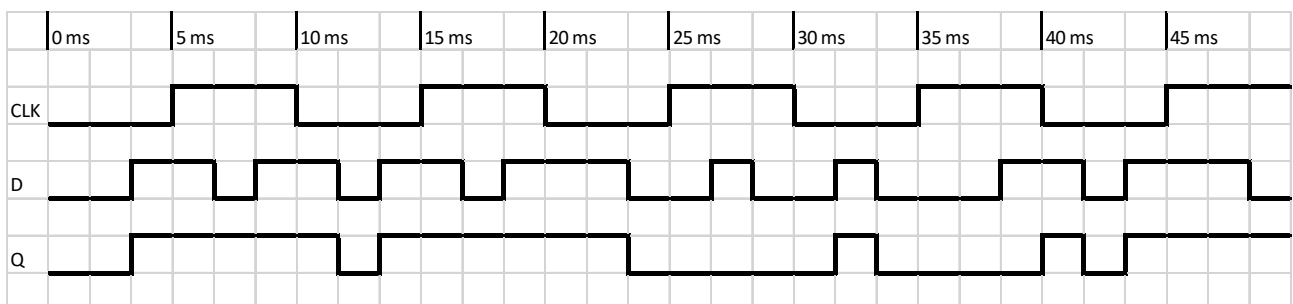
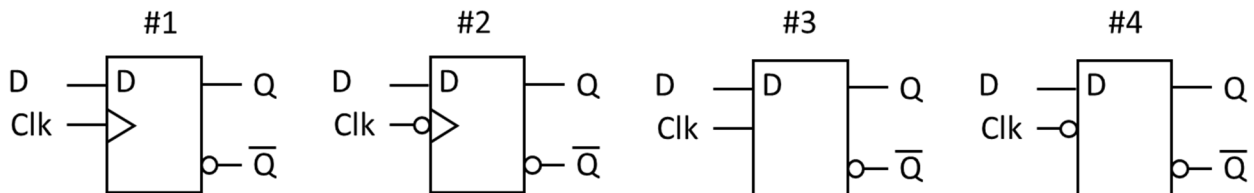

Answer: #4, Latch with inverted clk, transparent when clk is low

10 Timing calculation

Swedish: Beräkna maximal klockfrekvens för kretsen. Är Hold-villkoret uppfyllt?

English: Calculate the maximum clock frequency for the circuit. Is the Hold time constraint ok?

$t_{pcq} = 50 \text{ ps}$
 $t_{ccq} = 20 \text{ ps}$
 $t_{setup} = 50 \text{ ps}$
 $t_{hold} = 45 \text{ ps}$
 $t_{pd} = 100 \text{ ps}$
 $t_{cd} = 15 \text{ ps}$

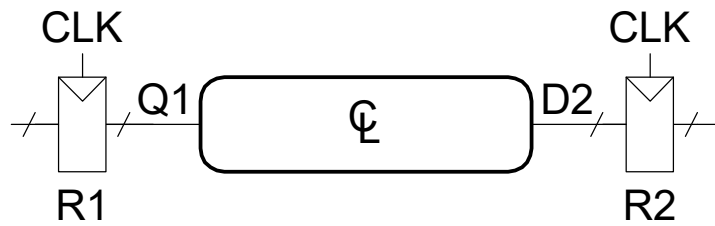

$$T_c = 50 + 50 + 100 = 200 \text{ ps} \quad f_c = 1 / T_c = \underline{5 \text{ GHz}} \quad 45 - 20 - 15 = 10 \text{ ps, Not ok}$$

11 Counter analysis

Swedish: Räknaren nedan har laddat in tillståndet $Q_3Q_2Q_1Q_0 = D_3D_2D_1D_0$.

Hur många tillstånd innan den upprepar sig? Vad är sista tillståndet?

English: The counter below has loaded state $Q_3Q_2Q_1Q_0 = D_3D_2D_1D_0$.

How many states until it repeats? What is the end state?

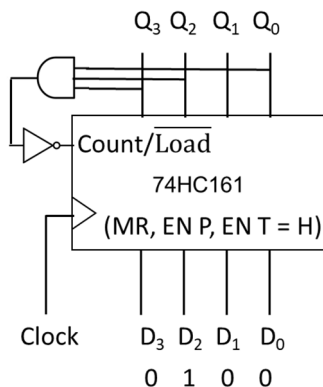

N = 10 Sequence: 0100 – 1101, **Last state is 1101**
 The last state will cause the load operation next clk.
 Count the number of states including the loaded state.

12 Counter design

Swedish: Hur ska AND-grunden och $D_3 - D_0$ kopplas för att få en räknare med tillståndsdigrammet nedan?

English: How should the AND-gate and $D_3 - D_0$ be connected to get a counter with the state diagram below?

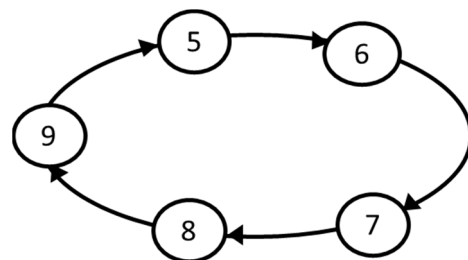
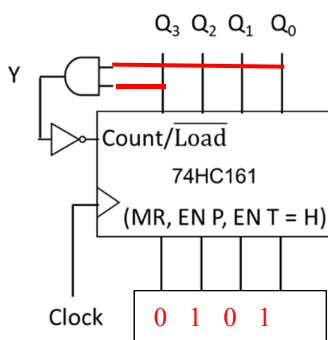

The AND gate should detect the last state, $Y = Q_3 \cdot Q_0$
 $D_3D_2D_1D_0$ should be connected to load the first state 0101

13 Multiplication

Swedish: A och B är 8 bitars två-komplement kodade tal.

Beräkna $A \times B$ (binärt) och svara med ett 16 bitars två-komplement **hexadecimalt kodat tal**.

Tänk på att du kan kontrollera dina beräkningar med decimala tal.

English: A and B are 8-bit binary (two's complement) numbers.

Calculate $A \times B$ (binary) and answer with a 16-bit binary (two's complement) **hexadecimal number**.

You can check your calculations using decimal numbers.

$$A = 01010101_2$$

$$B = 01110111_2$$

$A \times B = B \times A$ (both are positive) put B above since it has more '1's

$$\begin{array}{r} 01110111 \\ \times 01010101 \\ \hline 01110111 \quad \text{1st multiplication} \\ + 01110111 \quad \text{2nd multiplication} \\ \hline 1001010011 \\ + 01110111 \quad \text{3rd multiplication} \\ \hline 100111000011 \\ + 01110111 \quad \text{4th multiplication} \\ \hline 0010011110000011 = 2783_{16} \end{array}$$

14 Division

Swedish: A och B är 8 bitars två-komplement kodade tal.

Beräkna A / B (binärt) och svara med kvot och rest

(8 bitars två-komplement hexadecimalt kodade tal).

Tänk på att du kan kontrollera dina beräkningar med decimala tal.

English: A and B are 8-bit binary (two's complement) numbers.

Calculate A / B (binary) and answer with quotient and remainder

(8-bit binary two's complement hexadecimal numbers).

You can check your calculations using decimal numbers.

$$A = 10000001_2 \quad -A = 01111111_2$$

$$B = 11101111_2 \quad -B = 00010001_2$$

A and B are both negative, take 2's complement first, but results will be positive

$$\begin{array}{r} 111 \quad \text{Quotient} = 7 \\ 10001 / 01111111 \\ - 10001 \\ \hline 11101 \\ - 10001 \\ \hline 11001 \\ - 10001 \\ \hline 1000 \quad \text{Remainder} = 8 \end{array}$$

15 Full Addder

Swedish: Vad blir resultatet från kretsen nedan?

Svara med 8 bitar ($S_7 S_6 S_5 S_4 S_3 S_2 S_1 S_0$). Ignorera carry out (C_8).

English: What is the result for the circuit below?

Answer with 8 bits ($S_7 S_6 S_5 S_4 S_3 S_2 S_1 S_0$). Ignore carry out (C_8).

A = 1111

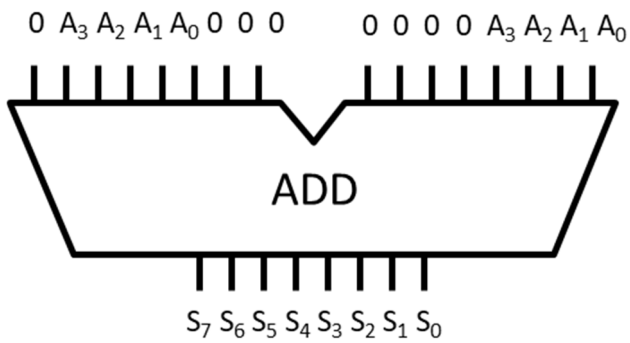

1111	(15)
+ 1111	(15*8)
10000111	(15*9=135)

16 Memory

Swedish: Detta ROM har 8 st 4 bitars tal, vilka är talen?

Svara med 8 decimala siffror, från adress 000 till 111.

English: This ROM has 8 4-bit numbers stored, what are the numbers?

Answer with 8 decimal numbers, from address 000 to 111.

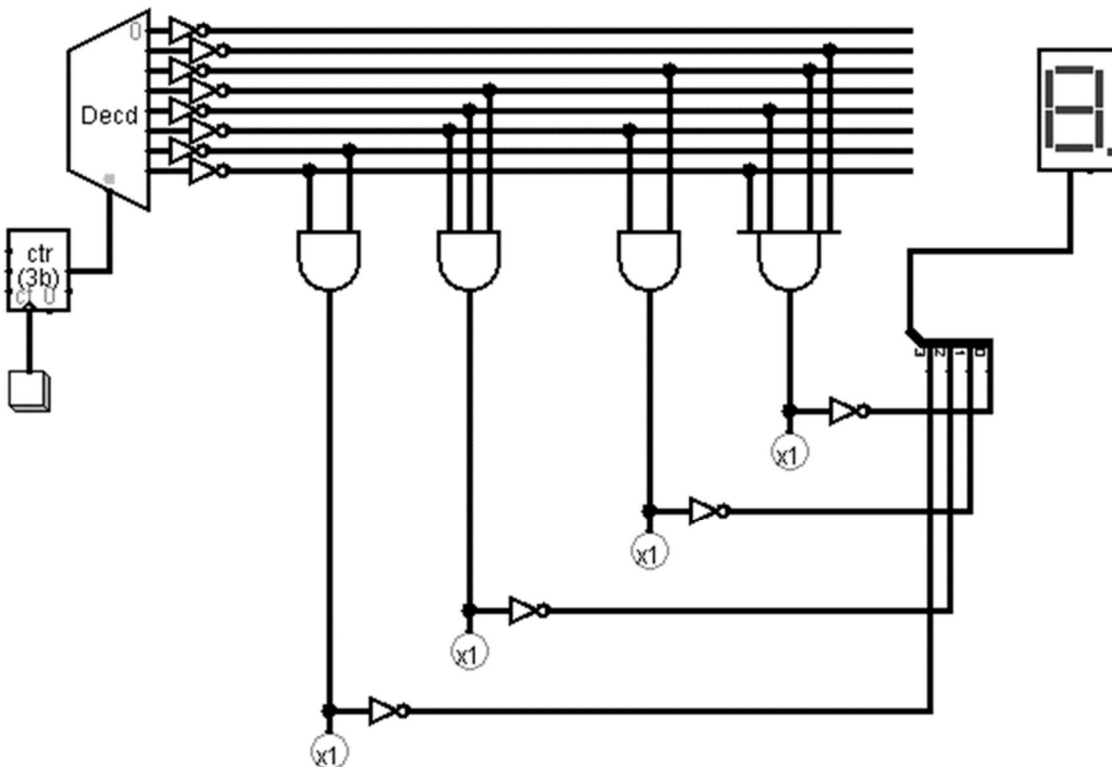

The number is 0 1 3 4 5 6 8 9

Del 2/Part 2, 4 points per exercise, answer on separate paper

17 Analysis of Combinational Circuit

Swedish:

1. Ta fram booleskt uttryck för kretsen nedan.
2. Rita K-map för kretsen med variabelordning som i figuren.
3. Förenkla uttrycket med hjälp av K-map.
4. Rita ny krets med enbart NOR-grindar.

English:

1. Derive the Boolean expression for the circuit below.
2. Draw a K-map for the circuit with variables as in the figure.
3. Simplify the expression using the K-map.
4. Draw a new circuit using only NOR gates.

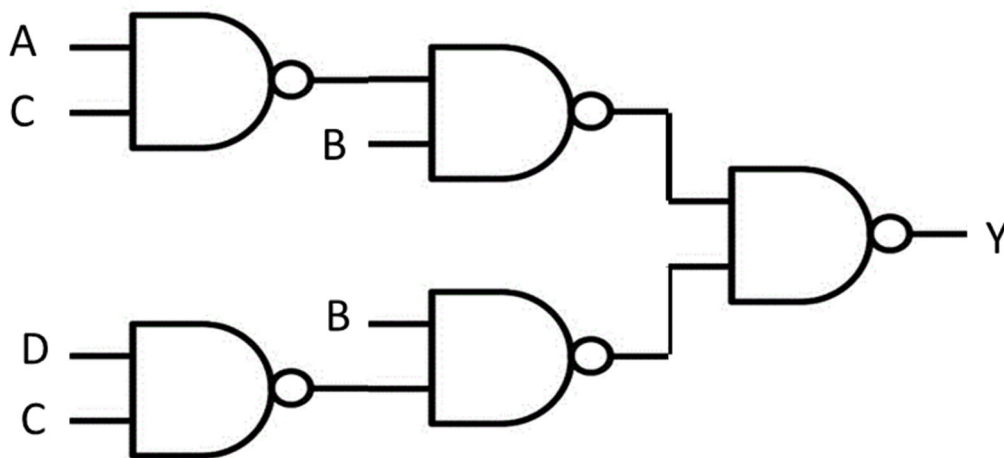

Y	CD 00	CD 01	CD 11	CD 10
AB 00	0	0	0	0
AB 01	1	1	1	1
AB 11	1	1	0	1
AB 10	0	0	0	0

Rita om K-map i dina
inlämnade svar.

Redraw the K-map in
your answer sheets.

Boolean expression and truth table

$$Y = \overline{\overline{\overline{A \cdot C} \cdot B} \cdot \overline{D \cdot C} \cdot B} = \overline{\overline{A \cdot C} \cdot B} + \overline{D \cdot C} \cdot B = (\overline{A} + \overline{C}) \cdot B + (\overline{D} + \overline{C}) \cdot B = B \cdot (\overline{A} + \overline{C} + \overline{D})$$

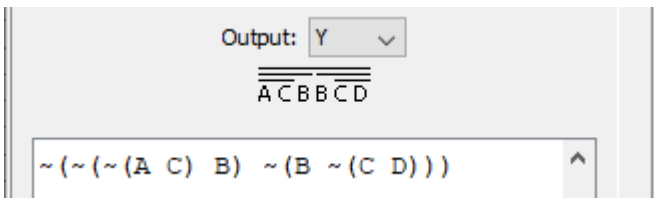

A	B	C	D	Y
0	0	0	0	0
0	0	0	1	0
0	0	1	0	0
0	0	1	1	0
0	1	0	0	1
0	1	0	1	1
0	1	1	0	1
0	1	1	1	1
1	0	0	0	0
1	0	0	1	0
1	0	1	0	0
1	0	1	1	0
1	1	0	0	1
1	1	0	1	1
1	1	1	0	1
1	1	1	1	0

K-Map and simplified expressions

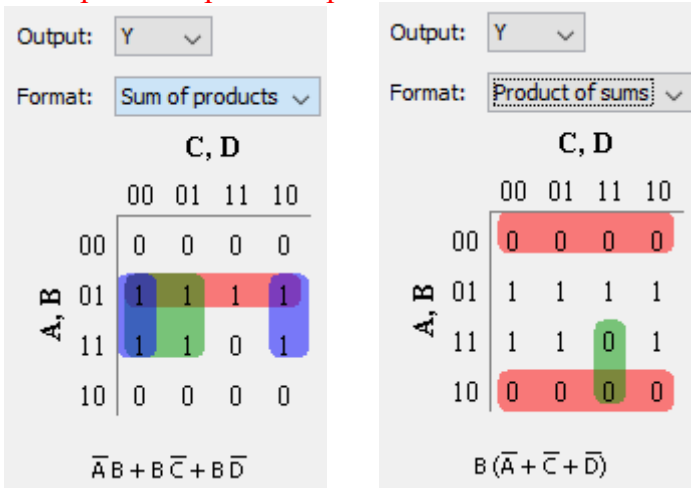

Can be simplified with Boolean Algebra (not necessary for full points) or from SOP:

$$Y = \overline{A} \cdot B + B \cdot \overline{C} + B \cdot \overline{D} = \overline{\overline{\overline{\overline{A} \cdot B} \cdot \overline{B \cdot \overline{C}} \cdot \overline{B \cdot \overline{D}}}} = \overline{\overline{A + B} + \overline{B + C} + \overline{B + D}} = \overline{A + B + B + C + B + D} = \overline{A + B + B + C + B + D}$$

Or better from starting from POS since it is NOR (inverters can be made with NOR gates):

$$Y = B \cdot (\overline{A} + \overline{C} + \overline{D}) = \overline{\overline{B \cdot (\overline{A} + \overline{C} + \overline{D})}} = \overline{\overline{B} + \overline{\overline{A} + \overline{C} + \overline{D}}}$$

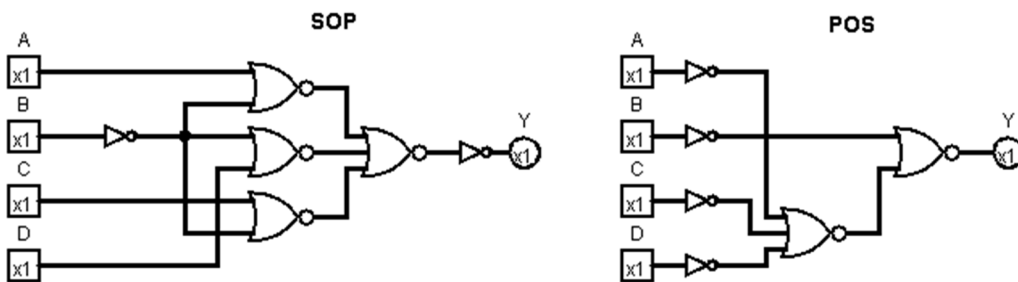

From original circuit using equivalence:

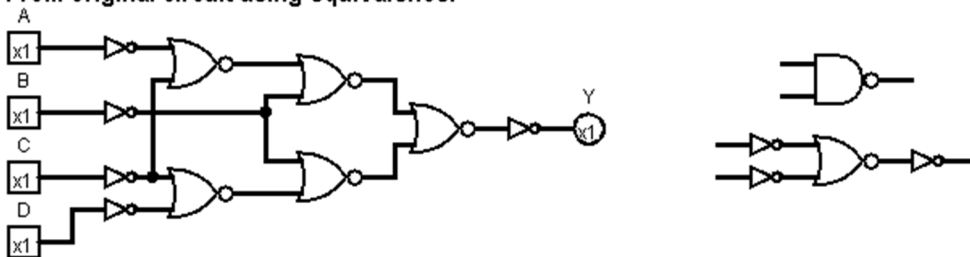

18 Design of Combinational Circuit

Swedish:

Konstruera kretsen för dekodern, som indikerar om primfaktorn 2, 3, 5, eller 7 finns i talet $q_3q_2q_1q_0$. Sanningstabellen är given nedan.

1. Rita 4 st K-maps för sanningstabellen med variabelordning som i figuren.
2. Ta fram enklast möjliga booleska uttryck från 4 st K-maps.
3. Rita 4 st kretsar för uttrycken med enbart NAND-grindar.
4. Rita en krets för K-map som använder en 4:1 Mux och grindar för uttryck P3.

English:

Design the circuit for a decoder, that indicates whether the prime factor 2, 3, 5, or 7 exist in the number represented by $q_3q_2q_1q_0$. The truth table is given below.

1. Draw 4 K-maps for the truth table with variables as in the figure.
2. Derive simplest possible Boolean expression from the 4 K-maps.
3. Draw 4 circuits for the expressions using only NAND-gates.
4. Draw a circuit for the K-Map using a 4:1 Mux and gates for expression P3.

	q_1q_0 00	q_1q_0 01	q_1q_0 11	q_1q_0 10
q_3q_2 00				
q_3q_2 01				
q_3q_2 11				
q_3q_2 10				

q_3	q_2	q_1	q_0	P2	P3	P5	P7
0	0	0	0	0	0	0	0
0	0	0	1	0	0	0	0
0	0	1	0	1	0	0	0
0	0	1	1	0	1	0	0
0	1	0	0	1	0	0	0
0	1	0	1	0	0	1	0
0	1	1	0	1	1	0	0
0	1	1	1	0	0	0	1
1	0	0	0	1	0	0	0
1	0	0	1	0	1	0	0
1	0	1	0	1	0	1	0
1	0	1	1	0	0	0	0
1	1	0	0	1	1	0	0
1	1	0	1	0	0	0	0
1	1	1	0	1	0	0	1
1	1	1	1	0	1	1	0

Rita om K-map i dina inlämnade svar.

Redraw the K-map in your answer sheets.

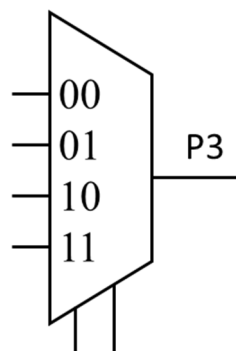

K-Maps and simplified expressions

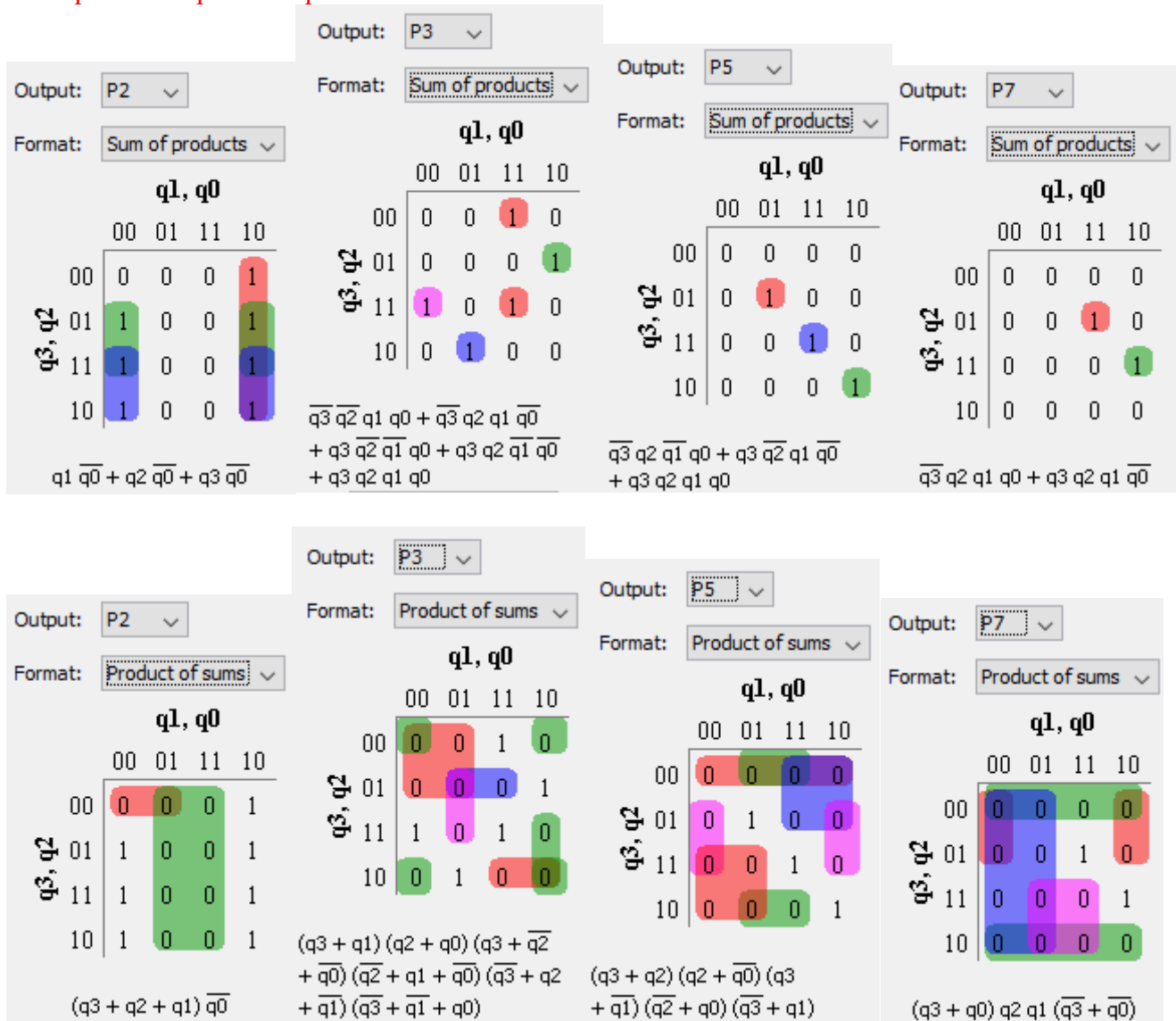

Normally use SOP for NAND only, and for this circuit the POS expressions are longer. (inverters are ok if you note that they can be made with a NAND) See next page.

MUX (2 out of several possibilities)

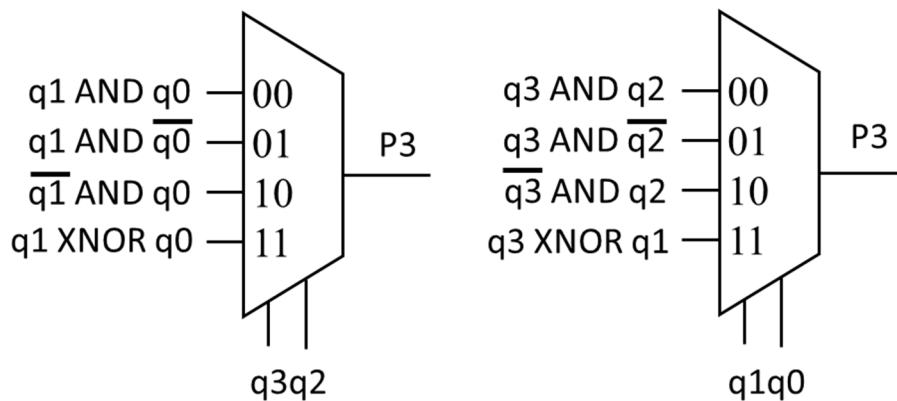

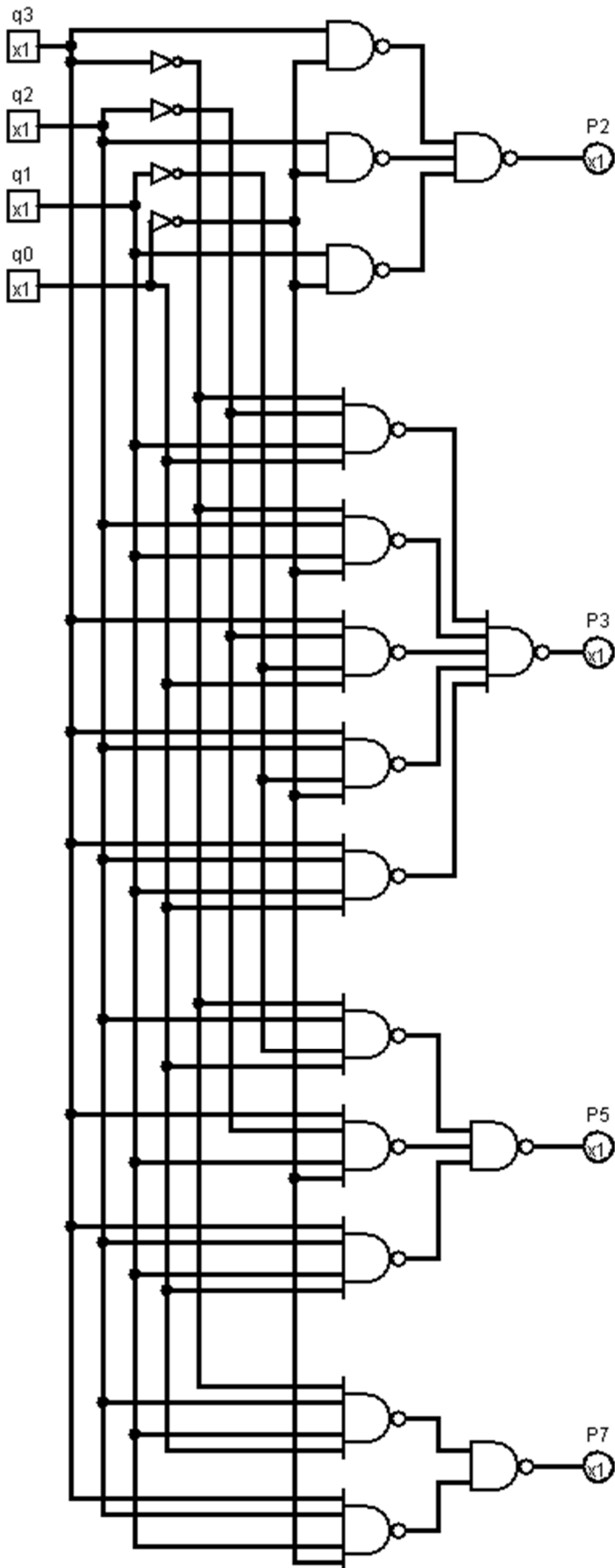

19 Analysis of FSM

Swedish: Analysera vad nedanstående tillståndsmaskin (FSM) utför.

1. Ta fram Boolska uttryck för nästa tillstånd Q_3+ Q_2+ Q_1+ Q_0+ och utsignal Y .
2. Rita K-Maps för Q_3+ Q_2+ Q_1+ Q_0+ och utsignal Y .
3. Rita tillståndstabell.
4. Rita tillståndsdigram.

Använd ordningen Q_3 Q_2 Q_1 Q_0 (det finns inga utsignaler förutom tillståndsvariablerna)

English: Analyze the state machine (FSM) below.

1. Derive Boolean expressions for next state Q_3+ Q_2+ Q_1+ Q_0+ and output Y .
2. Draw K-Maps for Q_3+ Q_2+ Q_1+ Q_0+ and output Y .
3. Draw a state table.
4. Draw a state diagram.

Use the order Q_3 Q_2 Q_1 Q_0 (there are no outputs except for the state variables)

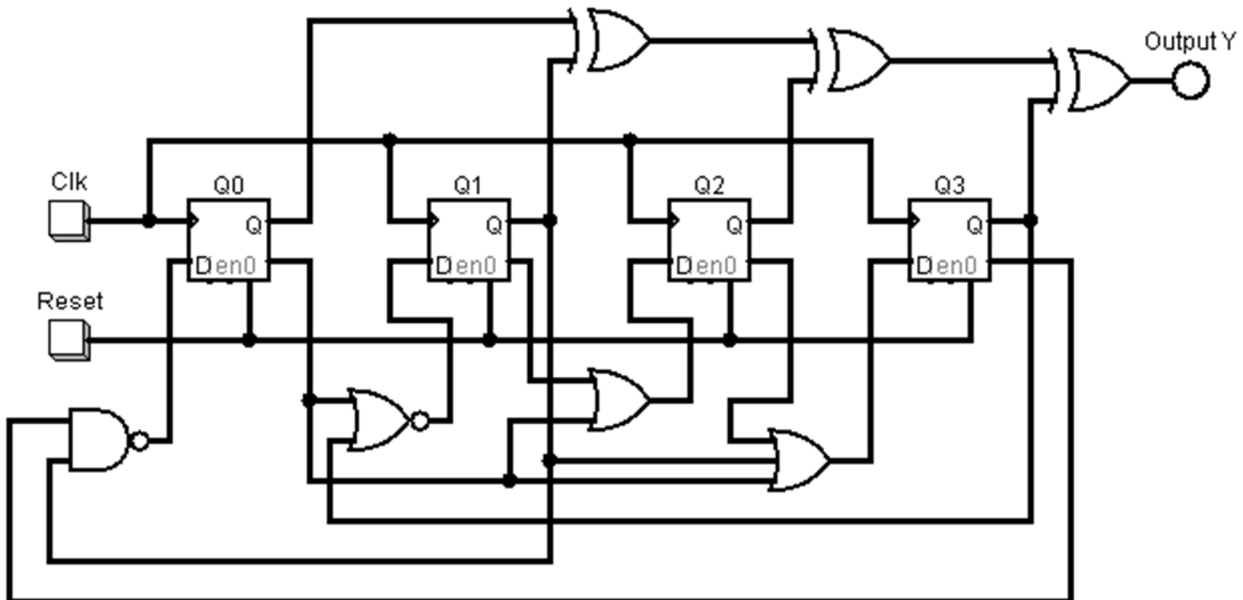

	$Q_1Q_0 =$			
	00	01	11	10
$Q_3Q_2 =$ 00				
01				
11				
10				

Rita om K-map i dina inlämnade svar.

Redraw the K-map in your answer sheets.

Boolean expressions

$$Q_3^+ = \overline{Q_2} + Q_1 + \overline{Q_0}$$

$$Q_2^+ = \overline{Q_1} + \overline{Q_0}$$

$$Q_1^+ = \overline{Q_3 + \overline{Q_0}} = \overline{Q_3} \cdot Q_0$$

$$Q_0^+ = \overline{Q_3} \cdot Q_1 = Q_3 + \overline{Q_1}$$

$$Y = Q_3 \oplus Q_2 \oplus Q_1 \oplus Q_0$$

Y is one for an odd number of ones

Y	Q ₁ Q ₀				
	00	01	11	10	
Q ₃ Q ₂	00	0	1	0	1
	01	1	0	1	0
11	0	1	0	1	
	10	1	0	1	0

K-Maps and state table

Q ₃ ⁺	Q ₁ Q ₀				Q ₂ ⁺	Q ₁ Q ₀			
	00	01	11	10		00	01	11	10
Q ₃ Q ₂	00	1	1	1	1	1	1	0	1
	01	1	0	1	1	1	1	0	1
11	0	1	0	1	1	1	1	0	1
	10	1	1	1	1	1	1	0	1

Q ₁ ⁺	Q ₁ Q ₀				Y	Q ₁ Q ₀			
	00	01	11	10		00	01	11	10
Q ₃ Q ₂	00	0	1	1	0	1	1	0	0
	01	0	1	1	0	1	1	0	0
11	0	0	0	0	0	1	1	1	1
	10	0	0	0	0	1	1	1	1

Present state				Next state				Output
Q ₃	Q ₂	Q ₁	Q ₀	Q ₃ ⁺	Q ₂ ⁺	Q ₁ ⁺	Q ₀ ⁺	
0	0	0	0	1	1	0	1	0
0	0	0	1	1	1	1	1	1
0	0	1	0	1	1	0	0	1
0	0	1	1	1	0	1	0	0
0	1	0	0	1	1	0	1	1
0	1	0	1	0	1	1	1	0
0	1	1	0	1	1	0	0	0
0	1	1	1	1	0	1	0	1
1	0	0	0	1	1	0	1	1
1	0	0	1	1	1	0	1	0
1	0	1	0	1	1	0	1	0
1	0	1	1	1	0	0	1	1
1	1	0	0	1	1	0	1	0
1	1	0	1	0	1	0	1	1
1	1	1	0	1	1	0	1	1
1	1	1	1	1	0	0	1	0

State diagram

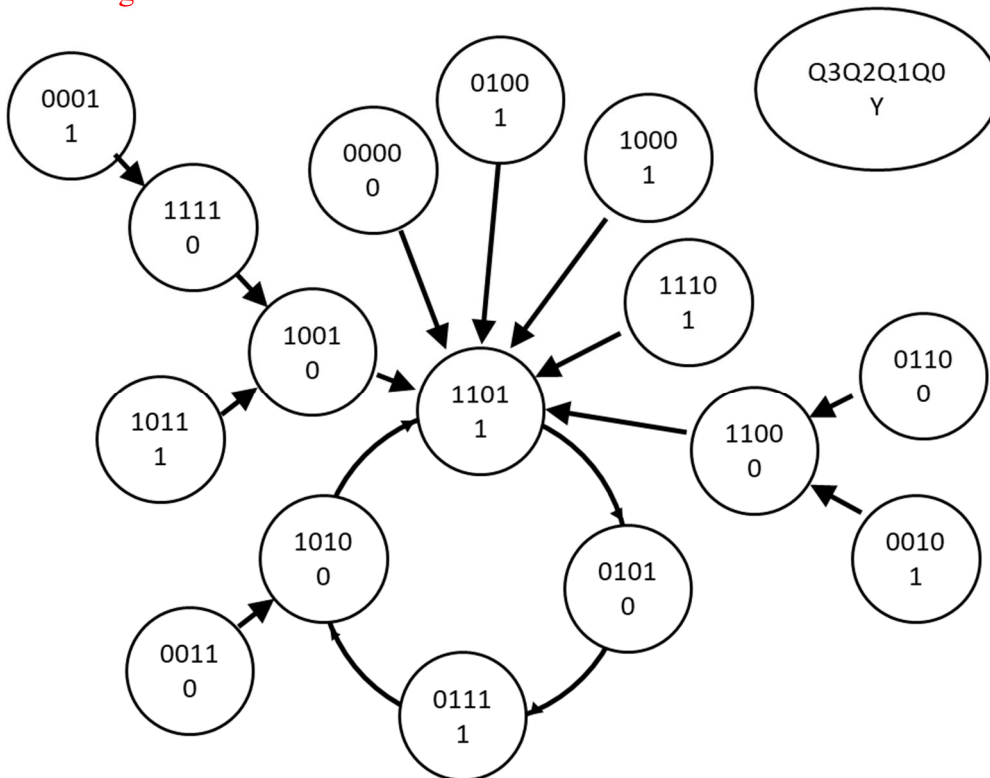

20 Design of FSM

Swedish: Konstruera en tillståndsmaskin (FSM) enligt tillståndsdigrammet nedan.

1. Rita tillståndstabell.
2. Ta fram K-map för nästa tillstånd och utsignalen Y.
3. Ta fram minimerade uttryck för nästa tillstånd och utsignal.
4. Rita kretsschema för en FSM med DFFs och vilka grindar som helst utom MUX.

English: Design a state machine (FSM) according to the state diagram below.

1. Draw a state table.
2. Derive K-maps for next state and output Y.
3. Derive minimized expressions for next state and output.
4. Draw the FSM circuit diagram with DFFs and any gates except MUX.

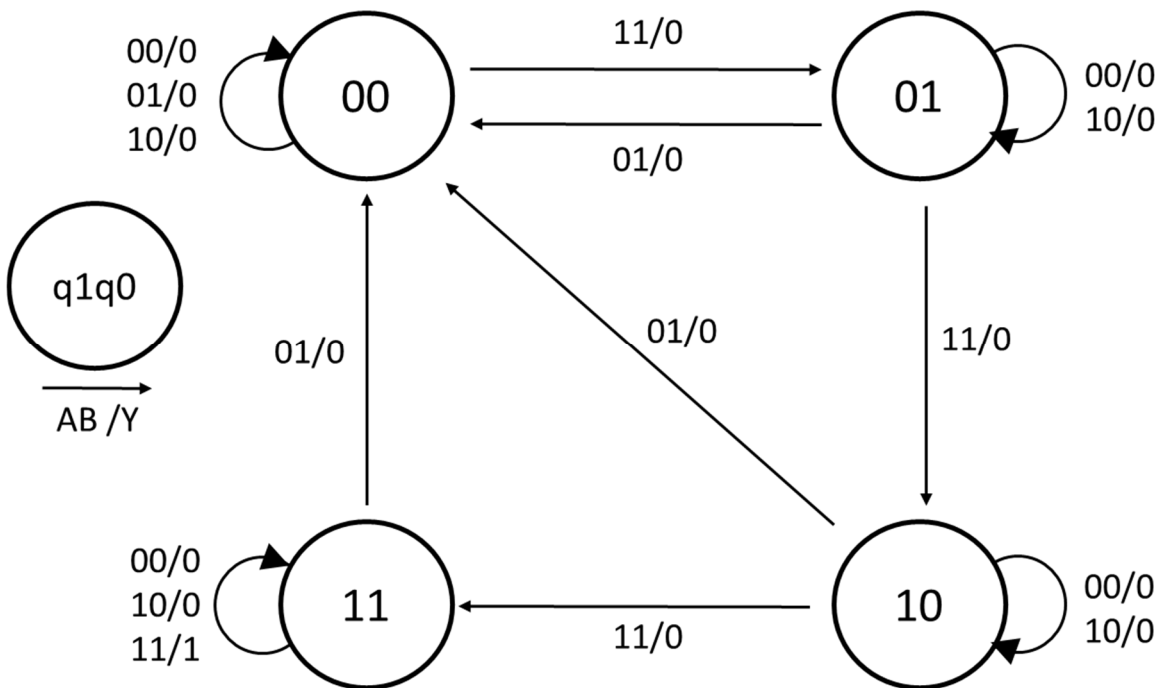

	AB 00	AB 01	AB 11	AB 10
q1q0 00				
q1q0 01				
q1q0 11				
q1q0 10				

Rita om K-map i dina
inlämnade svar.

Redraw the K-map in
your answer sheets.

State table

Present state		Next state								Out Y			
		AB = 00		AB = 01		AB = 11		AB = 10					
q1	q0	q1+	q0+	q1+	q0+	q1+	q0+	q1+	q0+	AB = 00	AB = 01	AB = 11	AB = 10
0	0	0	0	0	0	0	1	0	0	0	0	0	0
0	1	0	1	0	0	1	0	0	1	0	0	0	0
1	1	1	1	0	0	1	1	1	1	0	0	1	0
1	0	1	0	0	0	1	1	1	0	0	0	0	0

K-Maps for next state and output with minimized expressions (not necessary to draw Y)

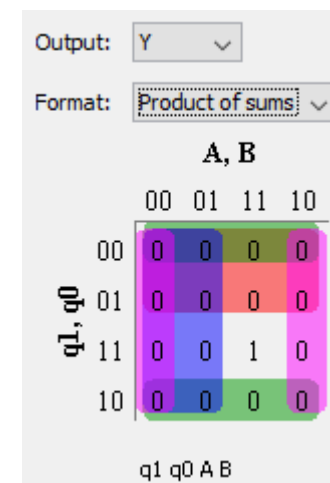
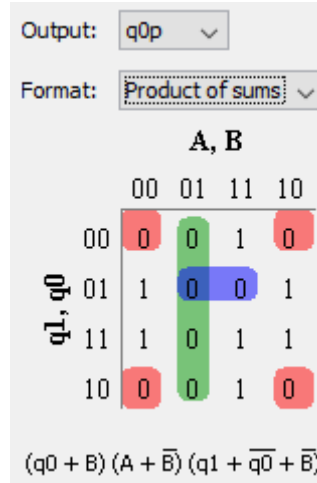
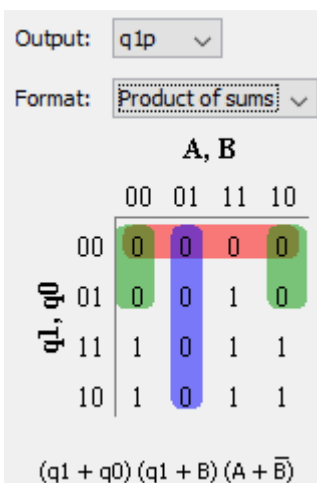
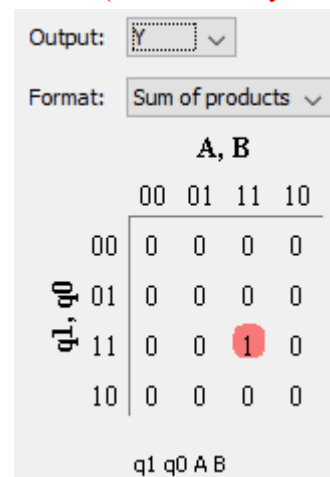
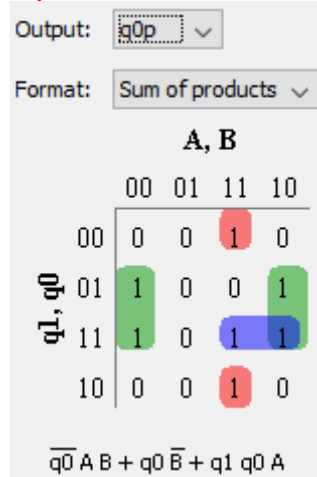
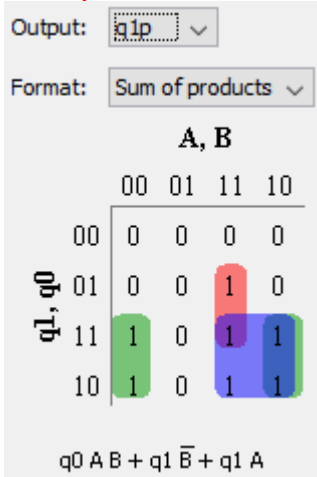

FSM circuit diagram (SoP version)

