

Brief introduction to Rutherford Backscattering Spectrometry

By Anders Hallén, September 2012

Rutherford backscattering spectrometry (RBS), as a technique to address thin film properties in materials research, has evolved from classical nuclear physics experiments conducted during the first half of the previous century. In the 1960's it was developed to a standard analysis technique particularly useful for the growing semiconductor field.

The basic principle is contained in the kinematics for binary collisions. A beam of known particles (ions) with mass M_1 is given the energy E_0 and directed onto the sample containing the particles M_2 that are to be investigated (see Fig. 1).

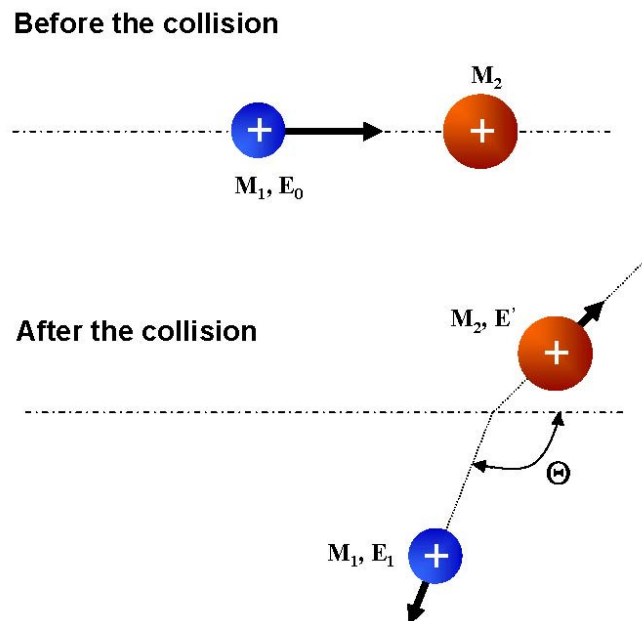

Fig. 1. A collision between two –positively charged– particles before and after the collision. Momentum and energy is conserved.

The energy E_1 and the scattering angle Θ of the particle M_1 are detected. From the conservation laws of energy and momentum, it is then possible to deduce the mass of the target particles M_2 . Furthermore, since the probability of scattering in a certain angle is known by the so called Rutherford cross section, it is also possible to estimate the abundance of M_2 particles in the sample by counting the yield of scattered particles M_1 in a certain solid angle covered by the detector.

A typical Rutherford backscattering setup consists of a particle accelerator that can deliver beams of low-mass ions in the MeV range. In Fig. 2 a tandem accelerator is used. This machine produces negative ions that are accelerated towards positive potential. The particles are transported in a vacuum system and at the high voltage terminal electrons are stripped off and the particle charge becomes positive. Then they are repelled by the high positive voltage and increase their energy further. The beam is then analysed and directed to the target chamber. The beam diameter is about a millimeter at the target.

The detector, a surface barrier detector, is normally mounted in a backscattering angle Θ of, for instance, 170° from the incident beam. As the incident particles penetrate the target matrix some of them will experience the Coulomb force from target nuclei and be deflected from their path. These collisions are governed by the Rutherford cross section and a small -but sufficient- number of the deflected ions will be backscattered into the detector.

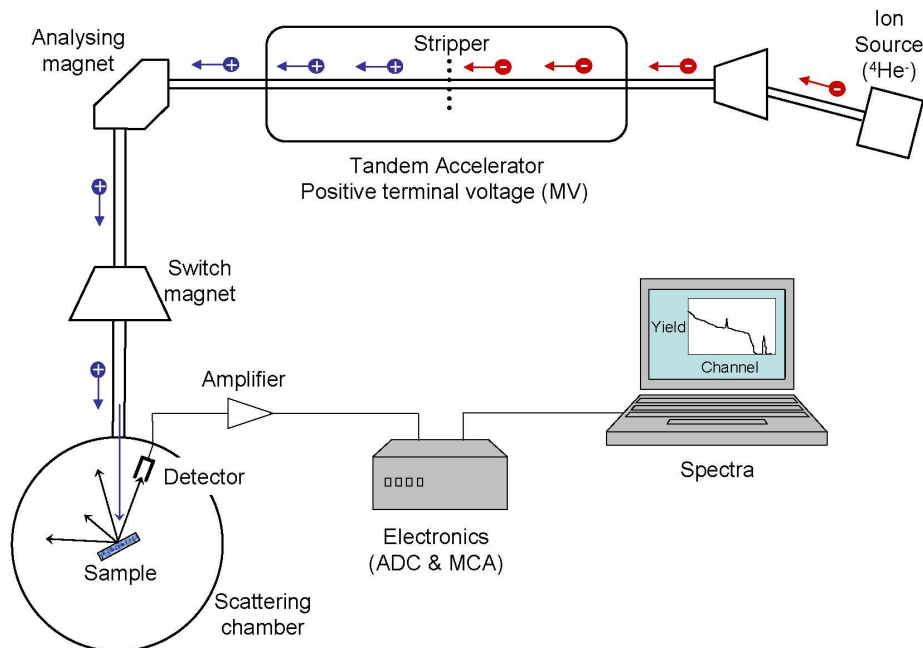

Fig. 2. Layout of a typical ion beam scattering setup including a tandem accelerator and scattering chamber in backscattering configuration.

Since the incident low-mass particles lose their energy also in other processes than elastic Rutherford events, the energy E_0 is not well defined at larger sample depths. However, it is possible to estimate the energy loss for the penetrating particles and obtain an accurate value for energy E_0 just before the collision. In fact, if the matrix is known, this energy loss can be converted to a depth scale and in this way the RBS technique can be used to make several micrometer deep profiles of different atomic species.

An example of a resulting RBS spectra is shown in Fig. 3. The sample is in this case a Si piece onto which a mixture of gold (Au), silver (Ag) and copper (Cu) has been evaporated. The spectrum shows the number of backscattered particles picked up by the detector as a function of their energy.

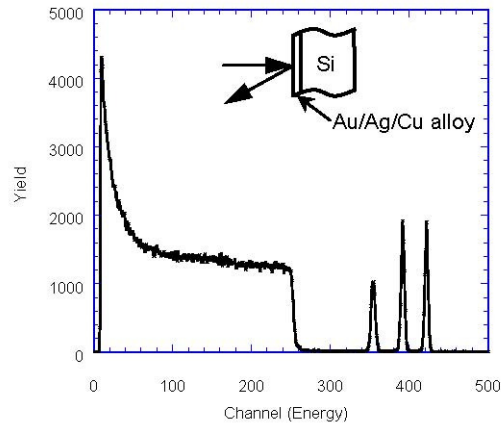

Fig. 3. The figure shows an RBS spectrum of a Si sample covered with a thin film of an Au/Ag/Cu-alloy. The yield, or number of detected backscattered particles, is plotted as a function of the energy of the particles. The probe particles in this case are 2.0 MeV ^4He and the backscattering angle $\Theta = 170^\circ$.

Questions to be answered before the laboration

After reading the brief introduction, and using your deep physical knowledge and some imagination, you should now be able to answer the following questions:

1. Explain the different features in the spectrum of Fig. 3.
2. Why is a thin gold film on a silicon matrix much easier to study by RBS than a thin Si film on an Au-matrix?
3. A typical unit for thickness of a film measured by RBS is cm^2 . How can this be converted to the more reasonable unit nm or μm ?
4. Does the sample orientation relative to the incident beam influence the yield of backscattered particles for a crystalline sample?
5. In Uppsala RBS is performed using a 5 MV tandem accelerator where one of the beam lines is equipped with a scattering chamber. What experimental parameters is it possible to control with this setup?

About the laboration

We will meet in the Ångström Laboratory in Uppsala at 13.15 on the day of the lab. We will meet at house five on the ground floor (from the main entrance, you walk pass the cafeteria and stop at the elevators on your right). We will then go through the basics for RBS technique and discuss your answers to the questions above. Then we will load samples and put the beam on. If you bring your own samples, which I welcome, the ideal format is a square cm chip with a thickness of one or two mm. This part of the laboration is more of a demonstration, since there is only limited room for your practical input. When we have obtained sufficient quality spectra from a few samples, the software used for spectra analysis is demonstrated. For your report you need to analyse the spectra and write not more than 4 pages about the RBS technique in general and the Uppsala setup in particular and also discuss the sample that you have analysed. The software you need for the analysis is free for a month and can be downloaded from the following address:

<http://www.rzg.mpg.de/~mam/Version5.html>

If you need to get in contact with me before I see you in Uppsala my address and numbers are:

Anders Hallén
Royal Inst. of Technology
Dept. of Microelectronics & IT
P.O. Box Electrum 229
SE 164 40 Kista-Stockholm, Sweden

Phone: 046 (0)8 790 4358
Fax: 046 (0)8 752 7782
e-mail: ahallen@kth.se

Further Reading

W.-K. Chu, J.W. Mayer, and M.-A. Nicolet
Backscattering Spectrometry
Academic Press, New York, 1978

J.R. Tesmer and M. Nastasi (eds.)
Handbook of Modern Ion Beam Analysis
Materials Research Society, Pittsburg, USA, 1995

J.F. Ziegler, J.P. Biersack, and U. Littmark
The Stopping and Ranges of Ions in Solids, Volume 1
Pergamon Press, New York, 1985

L.C. Feldman and J.W. Mayer
Fundamentals of Surface and Thin Film Analysis
Elsevier Science Publishing Co., 1986