



IL2218 Analog electronics, advanced course

Bengt Molin

Tel: 08-790 4448

E-post: bengt@kth.se

EKT – Devices and circuits

Kista, Electrum, elevator C, floor 4

Lecture 1

- Changes in the course
 - Prerequisite
 - Course information
 - Course registration
 - Student representatives for course evaluation meetings
-
- Ch 2 Basic MOS device physics

Course changes previous years

- Focus on design in CMOS technology
- Change of course book
 - Razavi, Design of Analog CMOS Integrated Circuits
 - Available at student book store
- Change of how the course is organized
- Change of examination

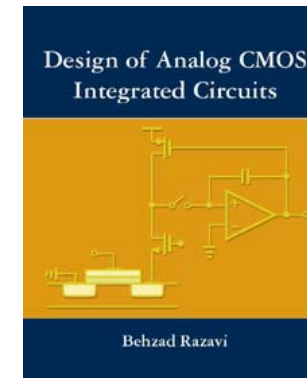

Prerequisite

- Basic course in Electrical circuits
 - Methods to solve for currents and voltage in electrical circuits
- Basic course in Analog electronics
 - Basic transistor based amplifiers
 - Understand transistor models
 - Biasing transistors
 - Small signal models
 - Use of operational amplifiers

Course outline

- Lectures
- Exercises, students solve selected problems from book and demonstrates his or hers solution at the exercise **Students responsible!**
- Labs, verify your solutions of selected problems with simulation
- Written exam, first part (questions, short problems) is closed book and second part (analysis and design problems) is open book
- [Course web page](#)

Chapter 1

- Why analog?
 - The nature is analog
 - Analog frontends in digital system
 - Amplification before A/D-conversion
- Why integrated?
 - All in same chip
- Why CMOS?
 - Digital and analog on same chip
 - Device scaling improving MOSFETs
- Why this book?
 - Analog design from both intuitive and rigorous angles

Chapter 2 Basic MOS Device Physics

MOS = Metal Oxide Semiconductor

NMOS

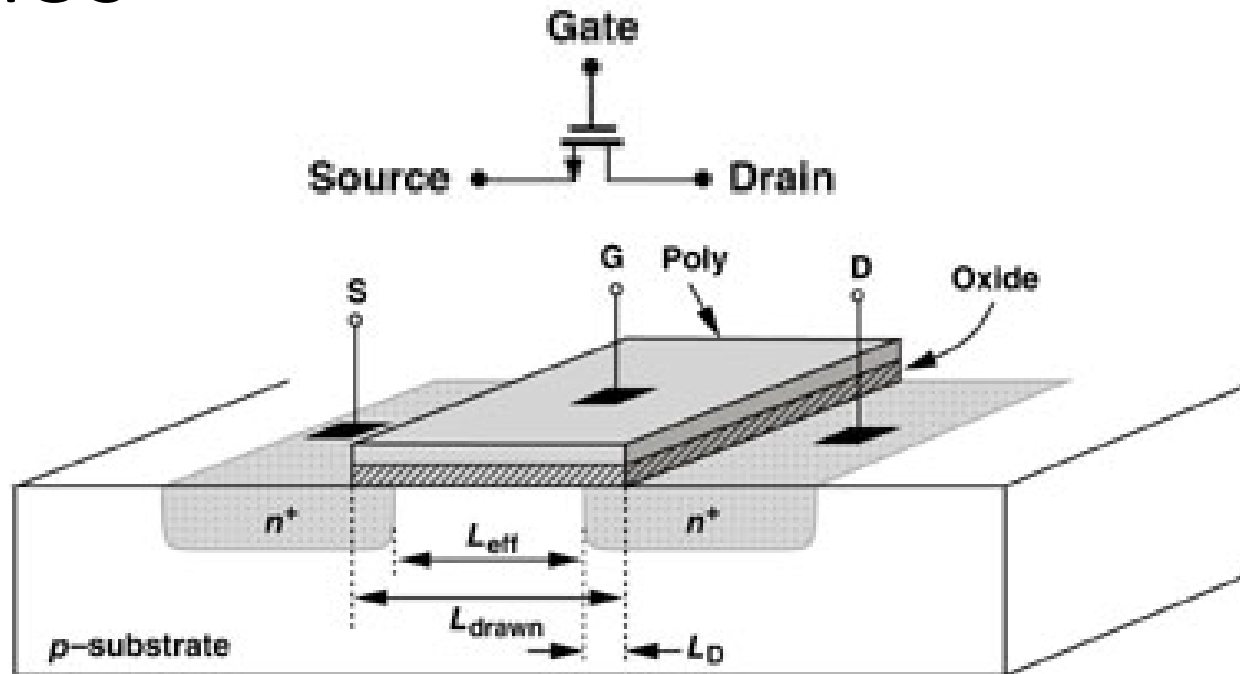

$$L_{eff} = L_{drawn} - 2L_D$$

NMOS PMOS CMOS

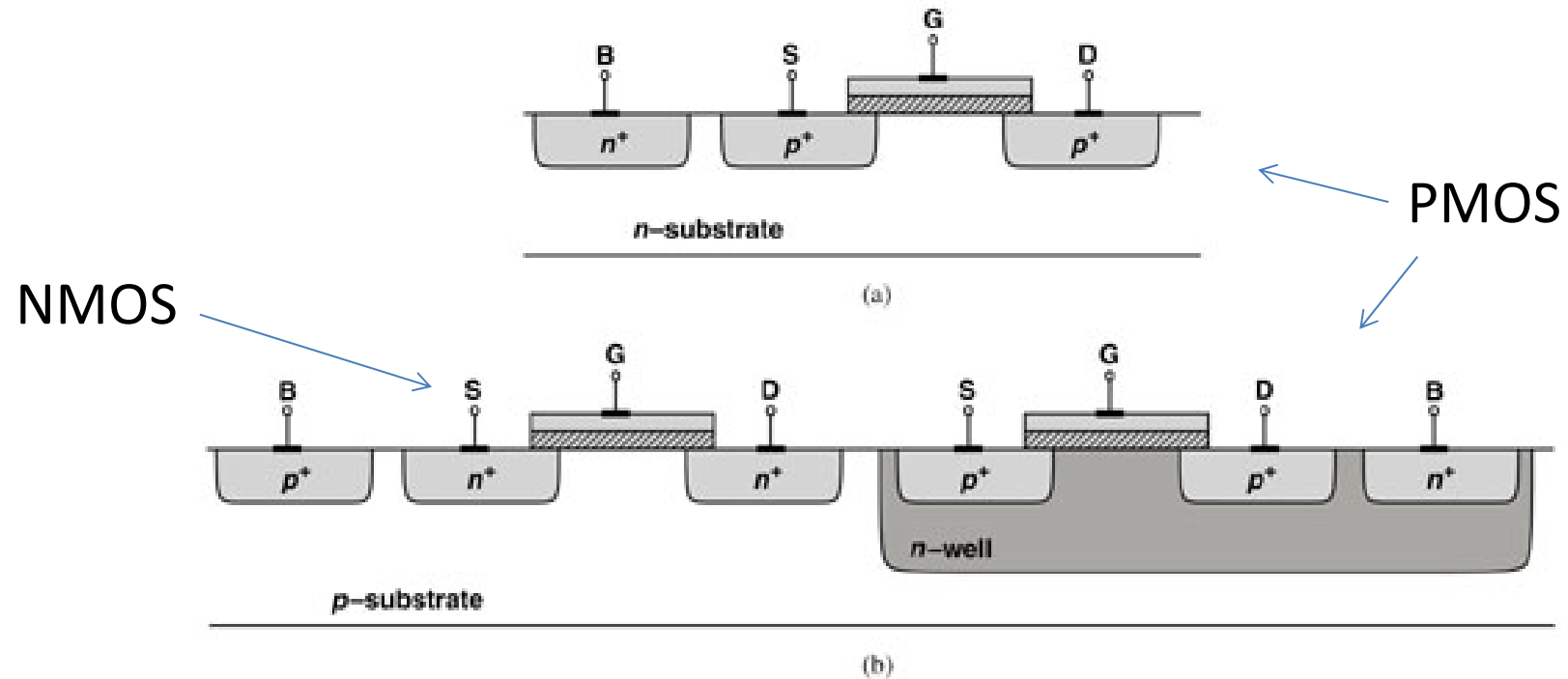

CMOS = Complementary MOS

MOS symbols

Four terminal

Three terminal

Digital

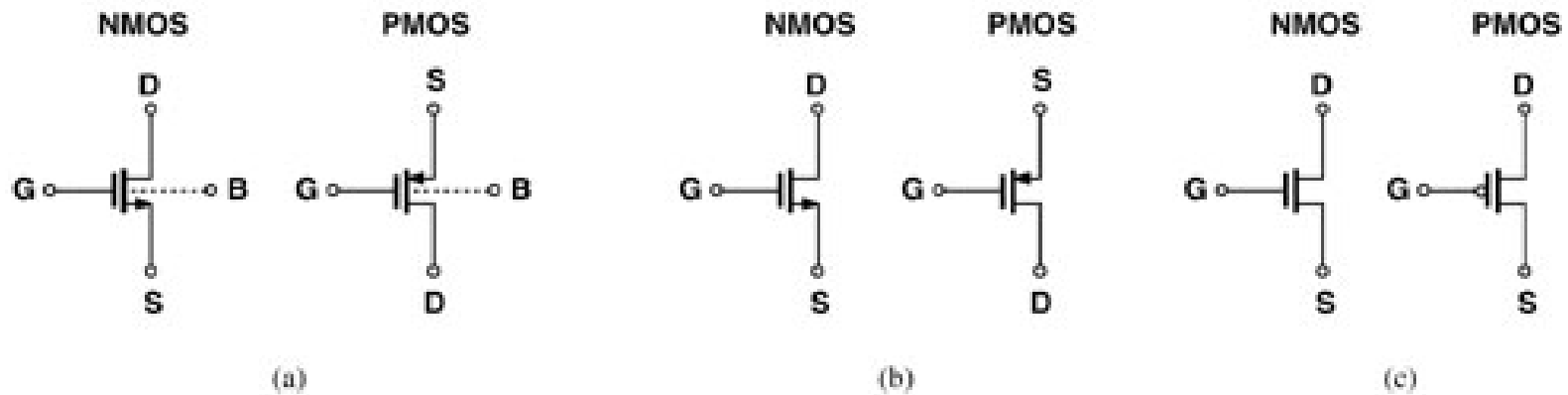

How is terminal body connected?

Threshold Voltage V_{TH}

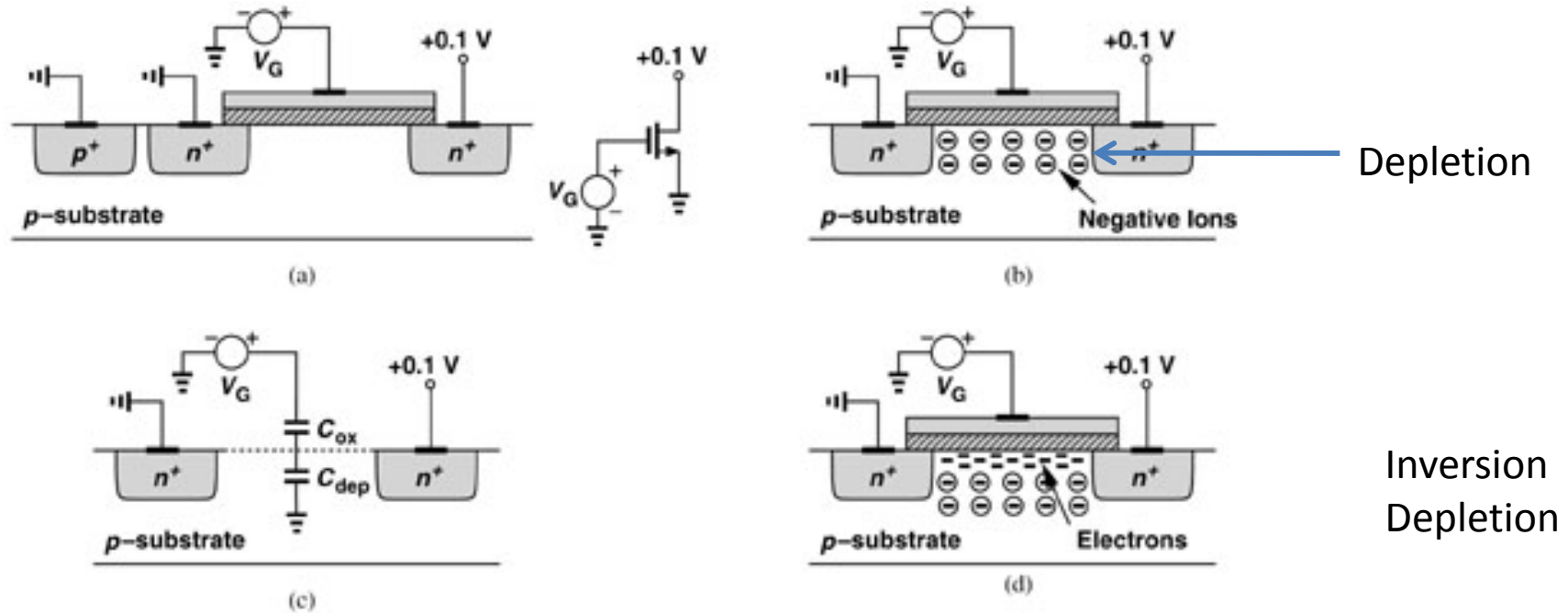

For $V_G > V_{TH}$ we have inversion and a N-channel from source to drain

Triode Region

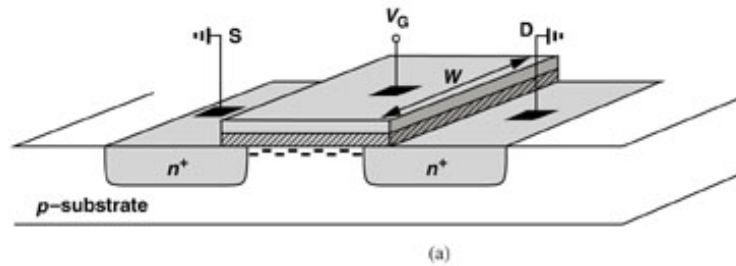

$$V_D \approx 0$$

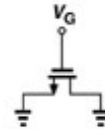

$$I = Q_d \cdot v$$

$$I_D = \underbrace{C_{ox} (V_{GS} - V_{TH}) W}_{\text{charge/unit length}} \underbrace{\mu_n \frac{V_{DS}}{L}}_{\text{velocity}}$$

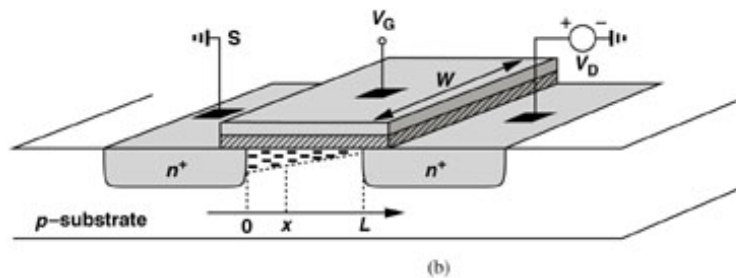

$$V_D > 0$$

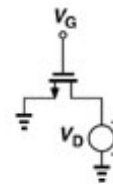

$$I_D = \underbrace{WC_{ox} (U_{GS} - V(x) - U_T)}_{\text{charge/unit length}} \cdot \underbrace{\mu_n \frac{dV(x)}{dx}}_{\text{velocity}}$$

Electrical field

$$I_D = \underbrace{WQ(x)}_{\text{decreases with } x} \cdot \underbrace{\mu_n \frac{dV(x)}{dx}}_{\text{increases with } x}$$

$$\text{If } Q(L) \rightarrow 0 \text{ then } \mu_n \frac{dV(L)}{dx} \rightarrow \infty$$

I/V Characteristics - Triode Region

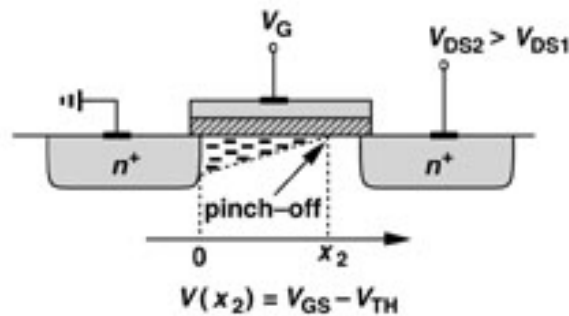
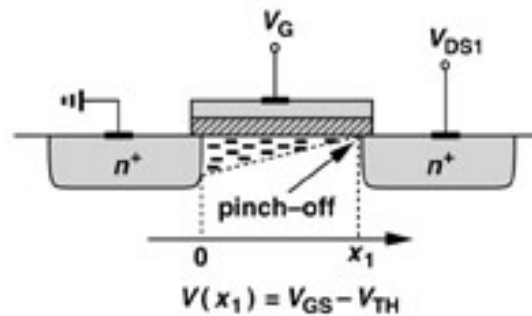

**Pinch off =
velocity saturation**

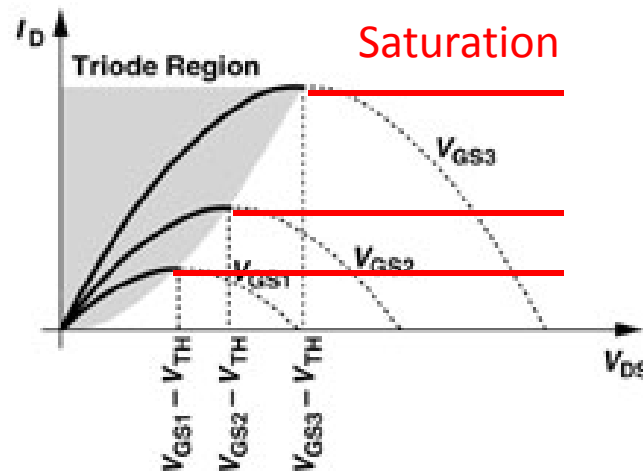

$$\int_{x=0}^L I_D dx = \int_{V=0}^{V_{DS}} WC_{ox} \mu_n [V_{GS} - V(x) - V_{TH}] dV$$

$$I_D = \mu_n C_{ox} \frac{W}{L} \left[(V_{GS} - V_{TH}) V_{DS} - \frac{1}{2} V_{DS}^2 \right]$$

Saturation (active) region

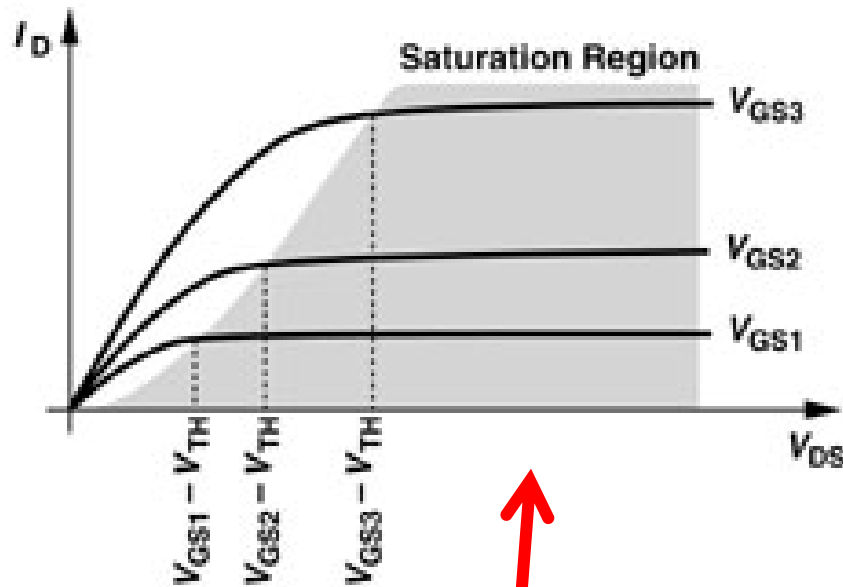

$$V_{DS} > V_{GS} - V_{TH} \quad (\text{Pinch-off})$$

$$I_D = \frac{\mu_n C_{ox}}{2} \frac{W}{L} (V_{GS} - V_{TH})^2$$

Body effect

If body potential is different from source potential, i.e. $V_{SB} \neq 0$ the threshold voltage will change. This is called **body effect**.

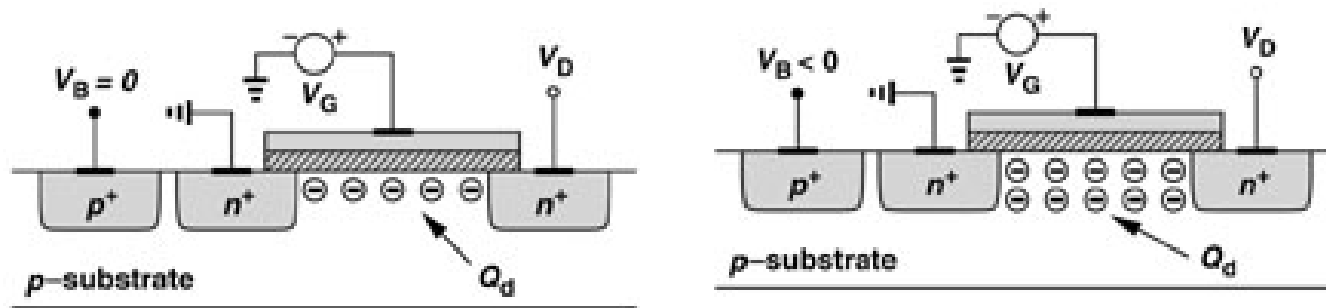

$$V_{TH} = V_{TH0} + \gamma \left(\sqrt{2\Phi_F + V_{SB}} - \sqrt{2\Phi_F} \right), \quad \gamma = \frac{\sqrt{2q\epsilon_{si}N_{sub}}}{C_{ox}}$$

Channel-Length Modulation

When V_{DS} increases, the channel will be slightly shorter due to depletion at drain. This will increase the current I_D .

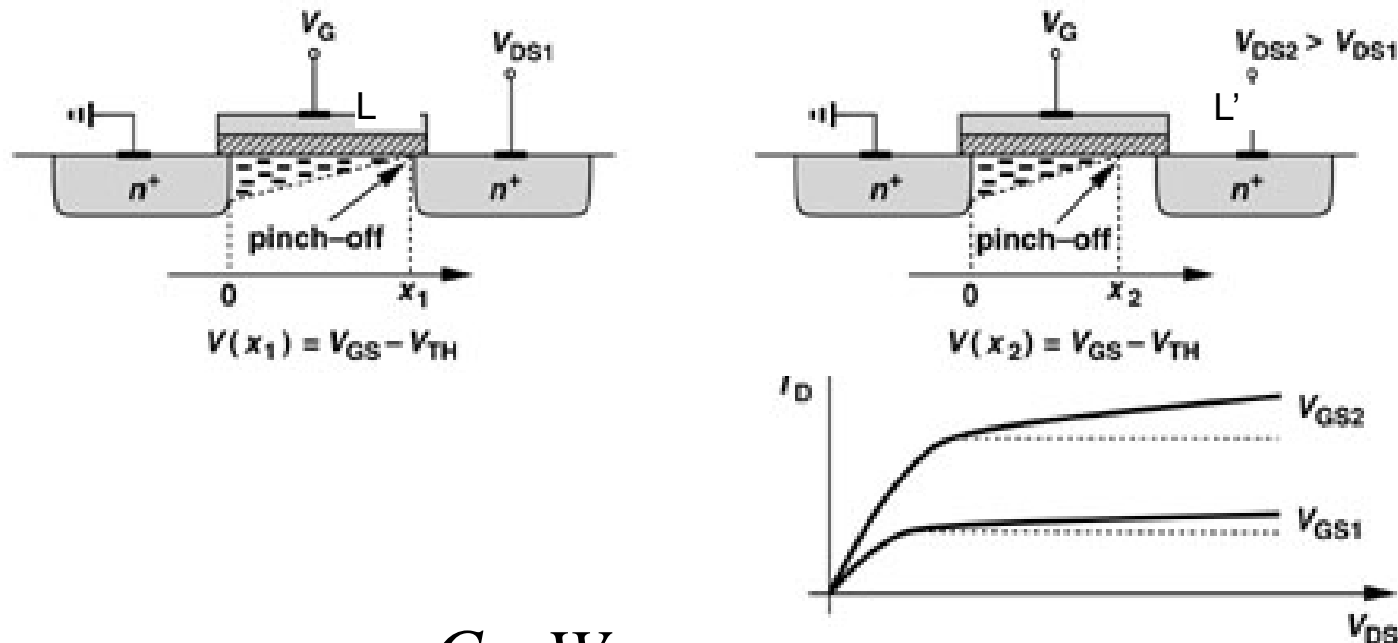

$$I_D = \frac{\mu_n C_{ox}}{2} \frac{W}{L} (V_{GS} - V_{TH})^2 (1 + \lambda V_{DS})$$

Subthreshold conduction

$$I_D = I_0 \exp\left(\frac{V_{GS}}{\zeta \frac{kT}{q}}\right)$$

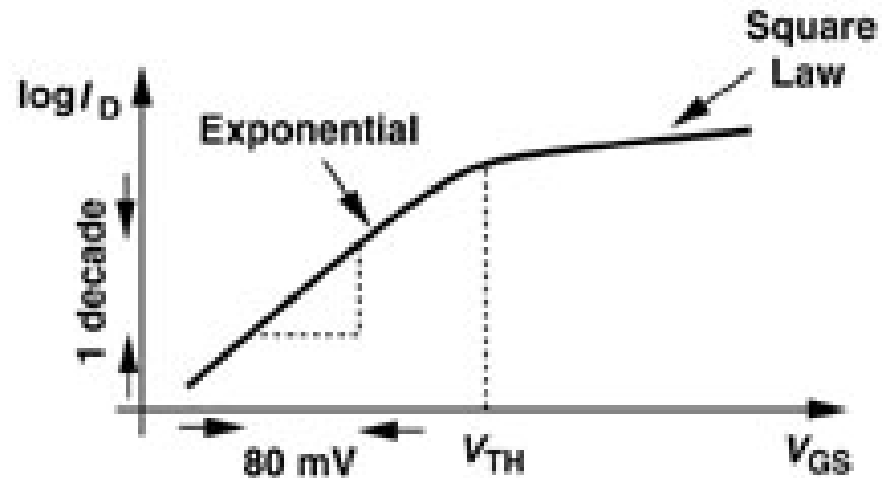

Transconductance

$$g_m = \mu_n C_{ox} \frac{W}{L} (V_{GS} - V_{TH}) = \sqrt{2\mu_n C_{ox} \frac{W}{L} I_D} = \frac{2I_D}{V_{GS} - V_{TH}}$$

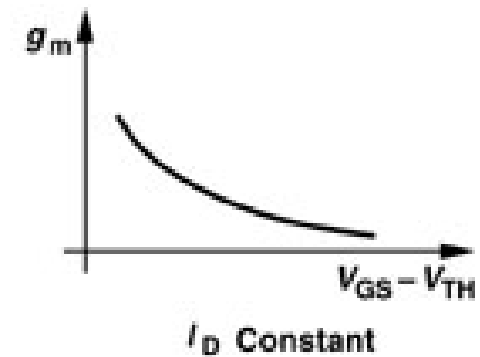
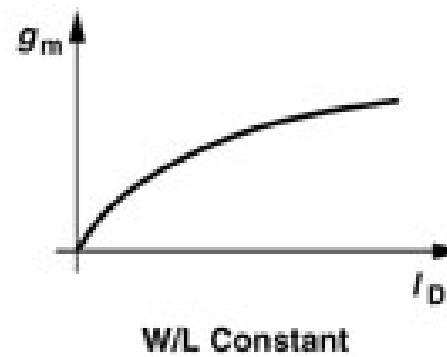
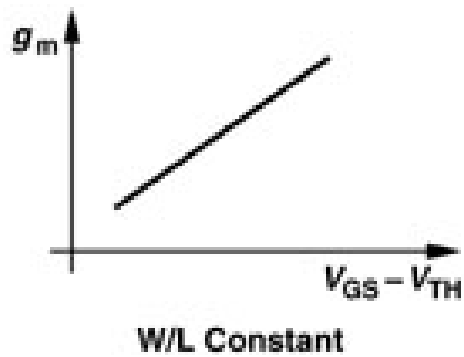

Bulk transconductance

Bulk behaves as a second gate

$$g_{mb} = \frac{\partial I_D}{\partial V_{BS}} = \frac{\mu_n C_{ox}}{2} \frac{W}{L} (V_{GS} - V_{TH}) \left(\frac{-\partial V_{TH}}{\partial V_{BS}} \right)$$

$$\frac{\partial V_{TH}}{\partial V_{BS}} = \frac{-\partial V_{TH}}{\partial V_{SB}} = -\frac{\gamma}{2} (2\Phi_F + V_{SB})^{-1/2}$$

$$g_{mb} = g_m \frac{\gamma}{2\sqrt{2\Phi_F + V_{SB}}} = \eta g_m$$

Output resistance

$$r_o = \frac{\partial V_{DS}}{\partial I_D} = \frac{1}{\partial I_D / \partial V_{DS}} = \frac{1}{\frac{\mu_n C_{ox}}{2} \frac{W}{L} (V_{GS} - V_{TH})^2 \lambda} = \frac{1}{\lambda I_D}$$

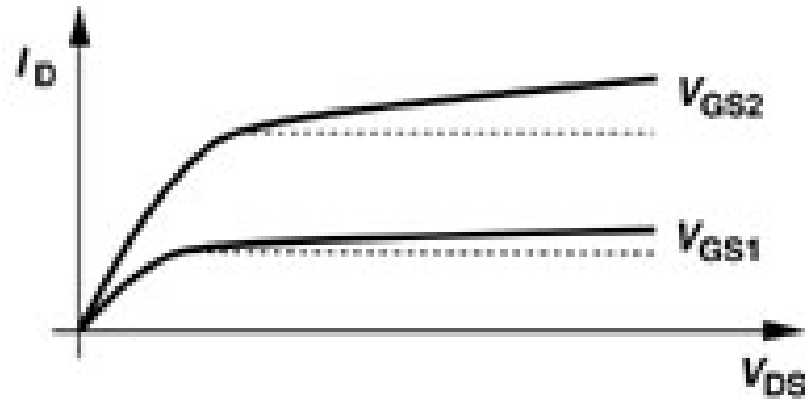

Small signal model

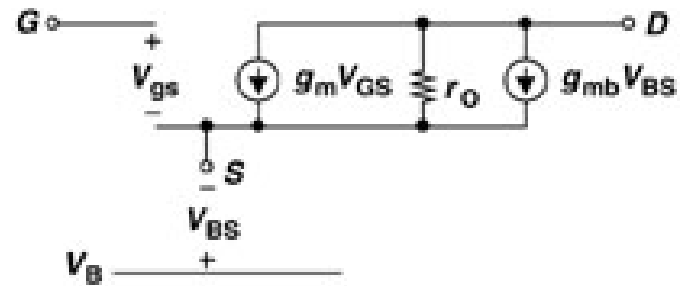
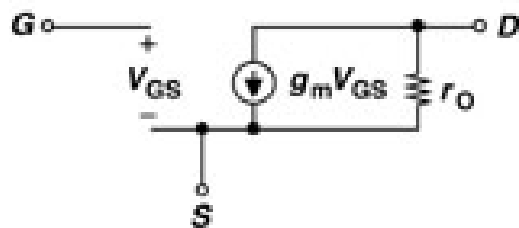
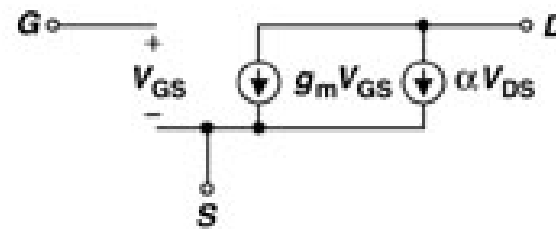
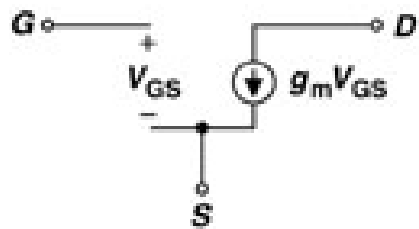

Complete small signal model with capacitances

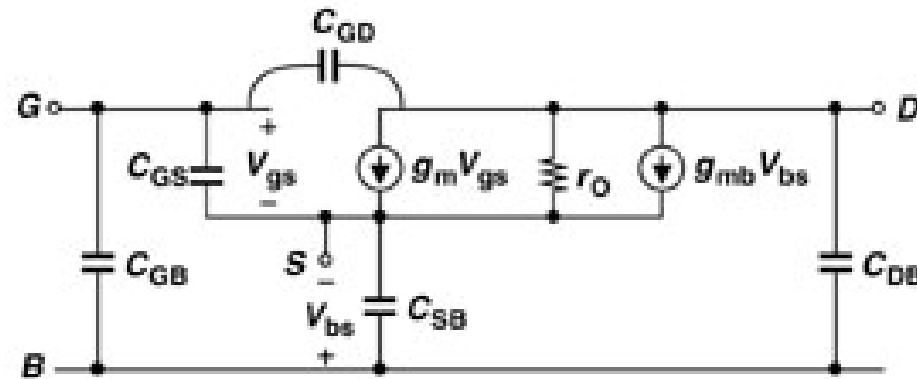
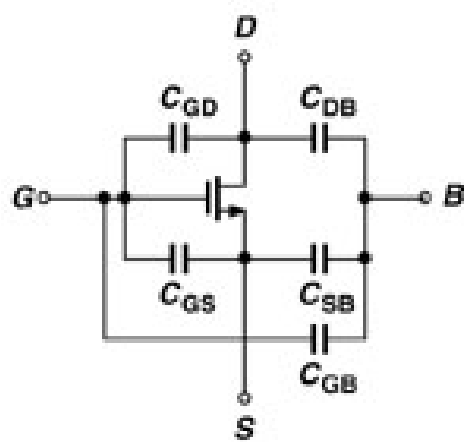

Explain the capacitances!

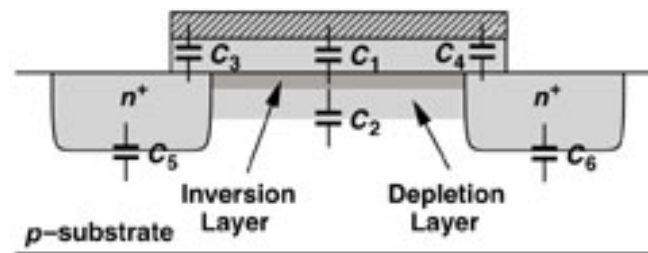

(a)

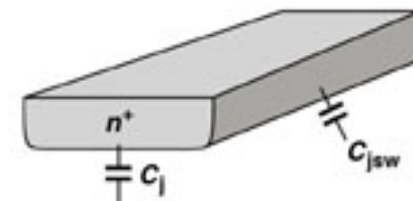

(b)

How to make an amplifier out of this?

Any ideas?