

## Lecture 6

# IL2218 Analog electronics, advanced course

- Chapter 6, Frequency response of amplifiers
  - Source follower, transfer function
  - Source follower, input impedance
  - Source follower, output impedance
  - Cascode amplifier
  - Differential amplifier

# Source follower

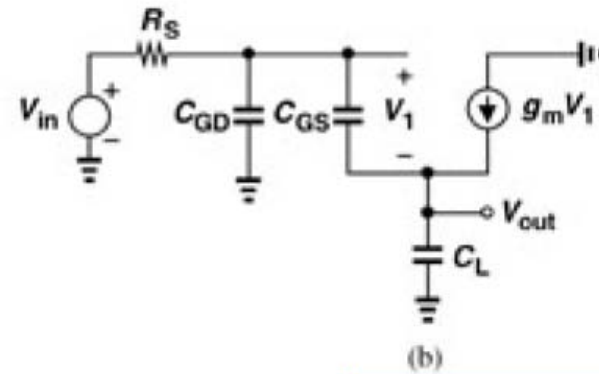
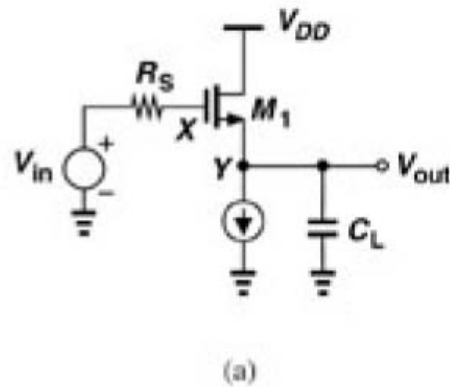

zero in left half plane

$$\frac{v_o}{v_i} = \frac{g_m + sC_{GS}}{s^2 R_S (C_{GS} C_L + C_{GS} C_{GD} + C_{GD} C_L) + s(g_m R_S C_{GD} + C_L + C_{GS}) + g_m}$$

Dominating pole

$$f_{p1} \approx \frac{g_m}{2\pi(g_m R_S C_{GD} + C_L + C_{GS})}, \text{ assuming } f_{p2} \gg f_{p1}$$

$$= \frac{1}{2\pi \left( R_S C_{GD} + \frac{C_L + C_{GS}}{g_m} \right)}$$

# Source follower, input impedance

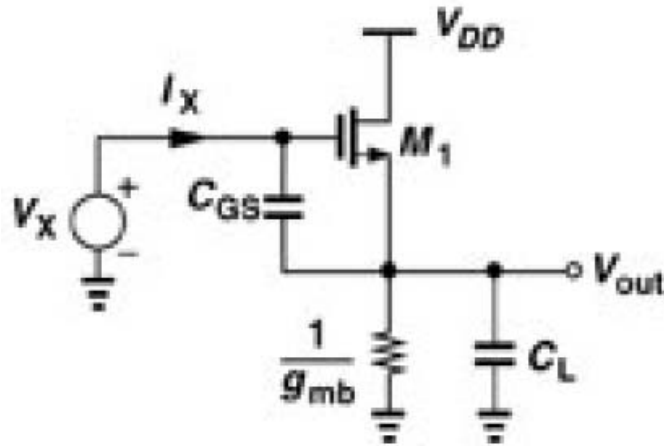

Neglecting  $C_{GD}$ ,

$$Z_{in} \approx \frac{1}{sC_{GS}} + \left(1 + \frac{g_m}{sC_{GS}}\right) \frac{1}{g_{mb} + sC_L}$$

At low frequencies,  $g_{mb} \gg |sC_L|$

$$Z_{in} \approx \frac{1}{sC_{GS}} \left(1 + g_m / g_{mb}\right) + 1 / g_{mb}$$

$$\therefore C_{in} = C_{GS} g_{mb} / (g_m + g_{mb}) + C_{GD} \quad ??? \quad \text{Error in book page 179?}$$

# Source follower, input impedance

At high frequencies,  $g_{mb} \ll |sC_L|$

$$Z_{in} \approx \frac{1}{sC_{GS}} + \frac{1}{sC_L} + \frac{g_m}{s^2 C_{GS} C_L}$$

At a particular frequency, input impedance includes  $C_{GD}$  in parallel with series combination of  $C_{GS}$  and  $C_L$  and a *negative* resistance equal to  $-g_m/(C_{GS}C_L\omega^2)$ .

# Source follower, output impedance

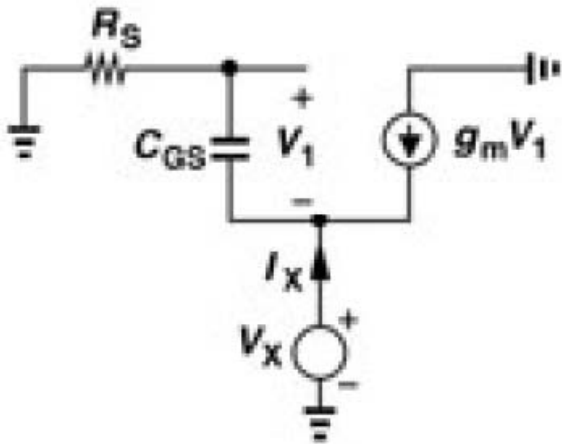

$$Z_{OUT} = V_X / I_X$$

$$= \frac{sR_S C_{GS} + 1}{g_m + sC_{GS}}$$

$\approx 1/g_m$  , at low frequencies

$\approx R_S$  , at high frequencies

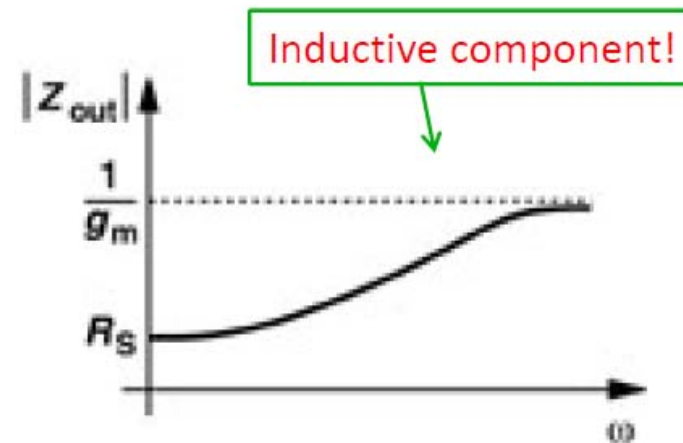
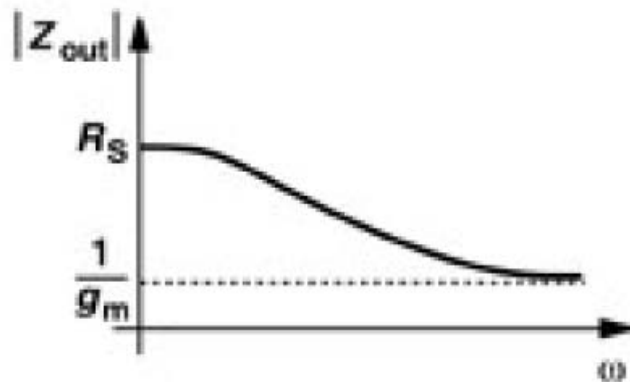

## Source follower - equivalent output impedance

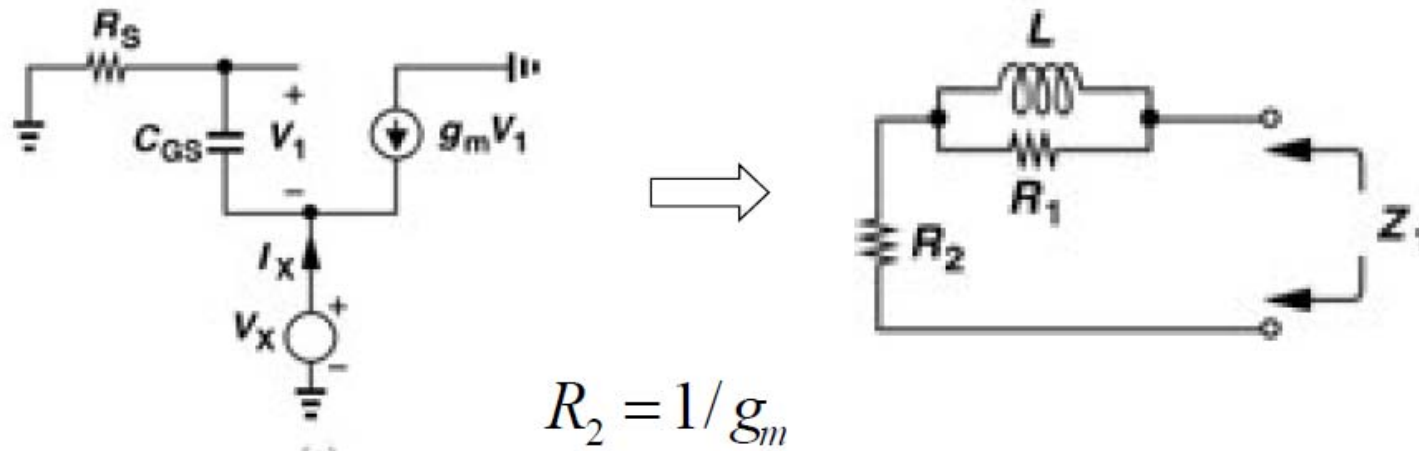

$$R_2 = 1/g_m$$

$$R_1 = R_S - 1/g_m$$

$$L = \frac{C_{GS}}{g_m} (R_S - 1/g_m)$$

Output impedance inductance dependent on source impedance,  $R_S$ !

# Step response, output ringing

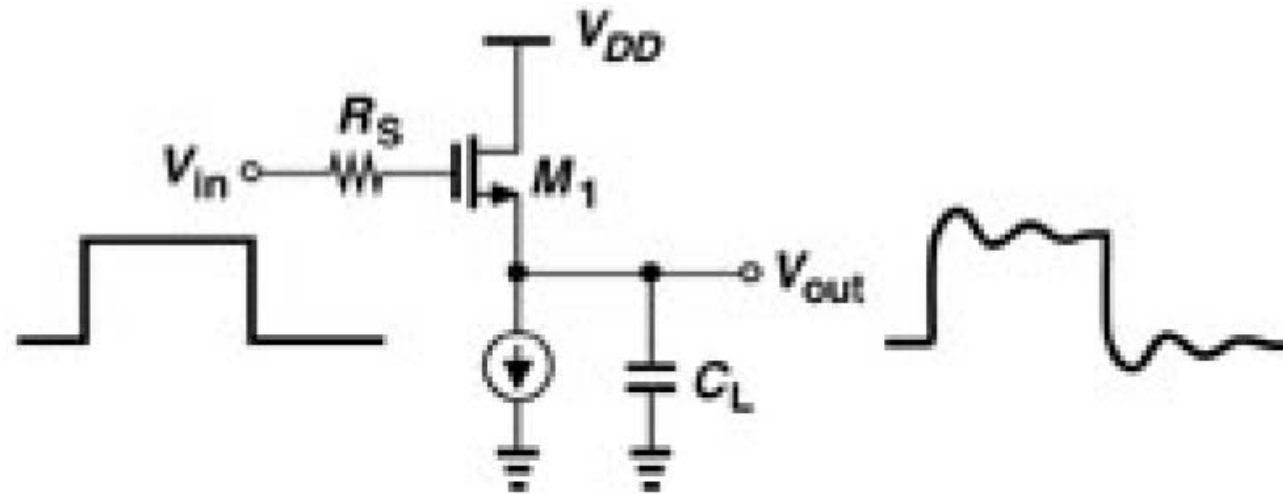

Output ringing due to tuned circuit formed with  $C_L$  and inductive component of output impedance.

# Cascode stage

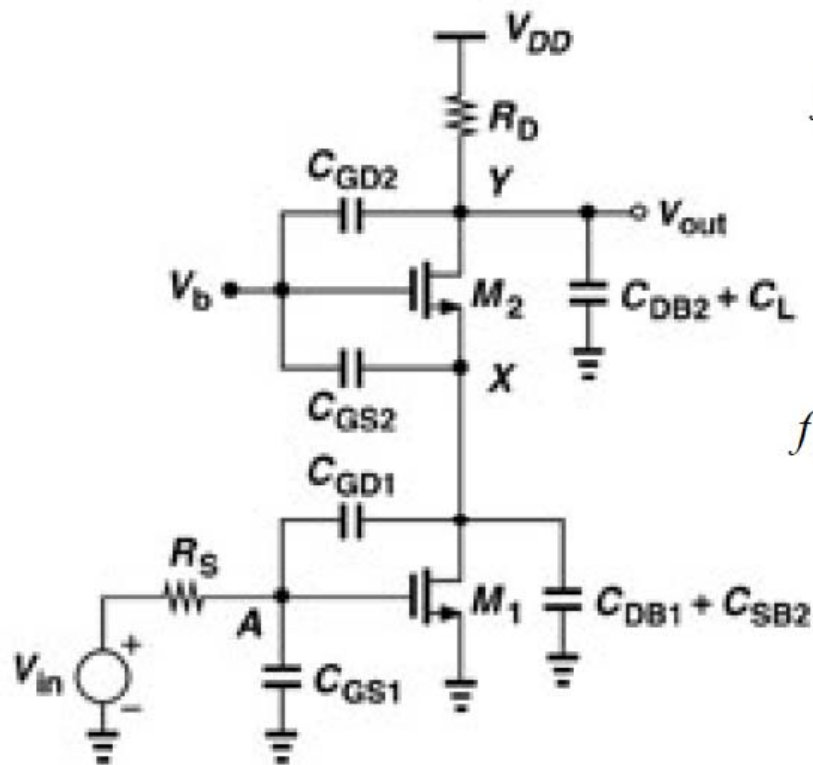

$$f_{pA} = \frac{1}{2\pi R_S \left[ C_{GS1} + C_{GD1} \left( 1 + \frac{g_{m1}}{g_{m2} + g_{mb2}} \right) \right]}$$

$$f_{pX} = \frac{g_{m2} + g_{mb2}}{2\pi (2C_{GD1} + C_{DB1} + C_{SB2} + C_{GS2})}$$

$$f_{pY} = \frac{1}{2\pi R_D (C_{DB2} + C_L + C_{GD2})}$$

# Differential amplifier

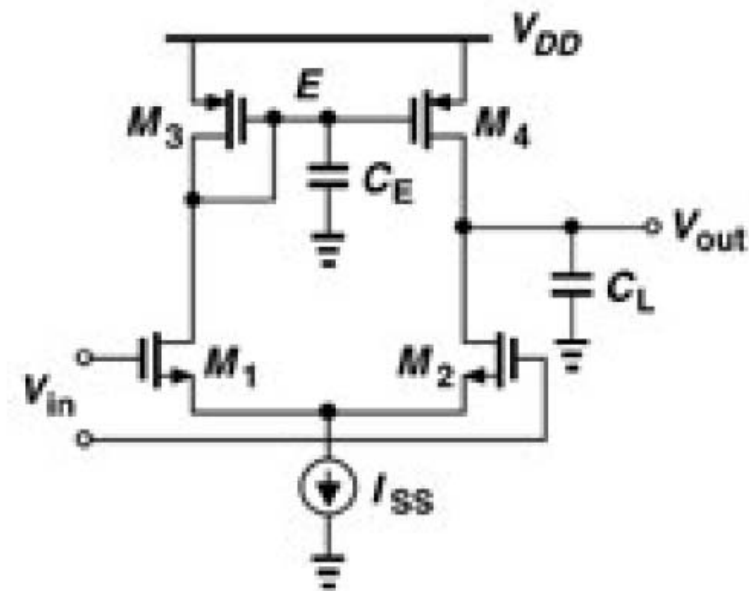
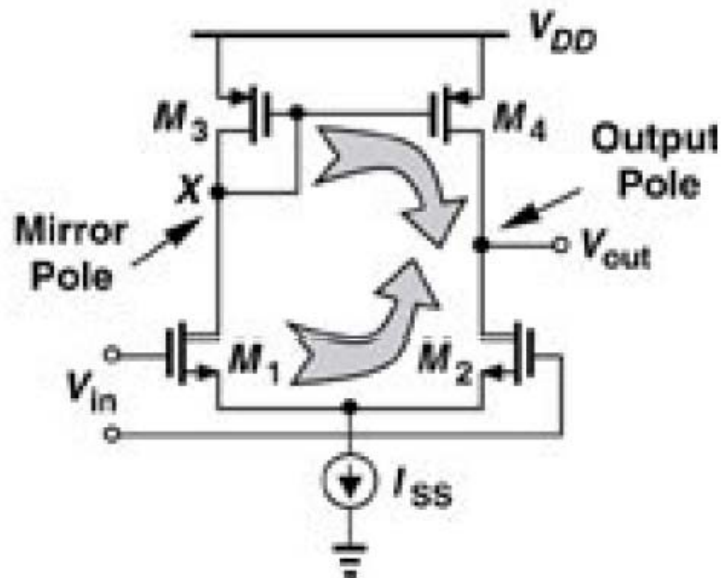

$$f_{p1} \approx \frac{1}{2\pi(r_{oN} \parallel r_{oP})C_L} \quad f_{p2} = \frac{g_{mP}}{2\pi C_E} \quad f_Z = 2f_{p2} = \frac{2g_{mP}}{2\pi C_E}$$