

Föreläsning 8

IE1332 Utveckling av elektronikprodukter

Kapitel 13

- Interface
- Filtrering

Differential och common mode på kablar

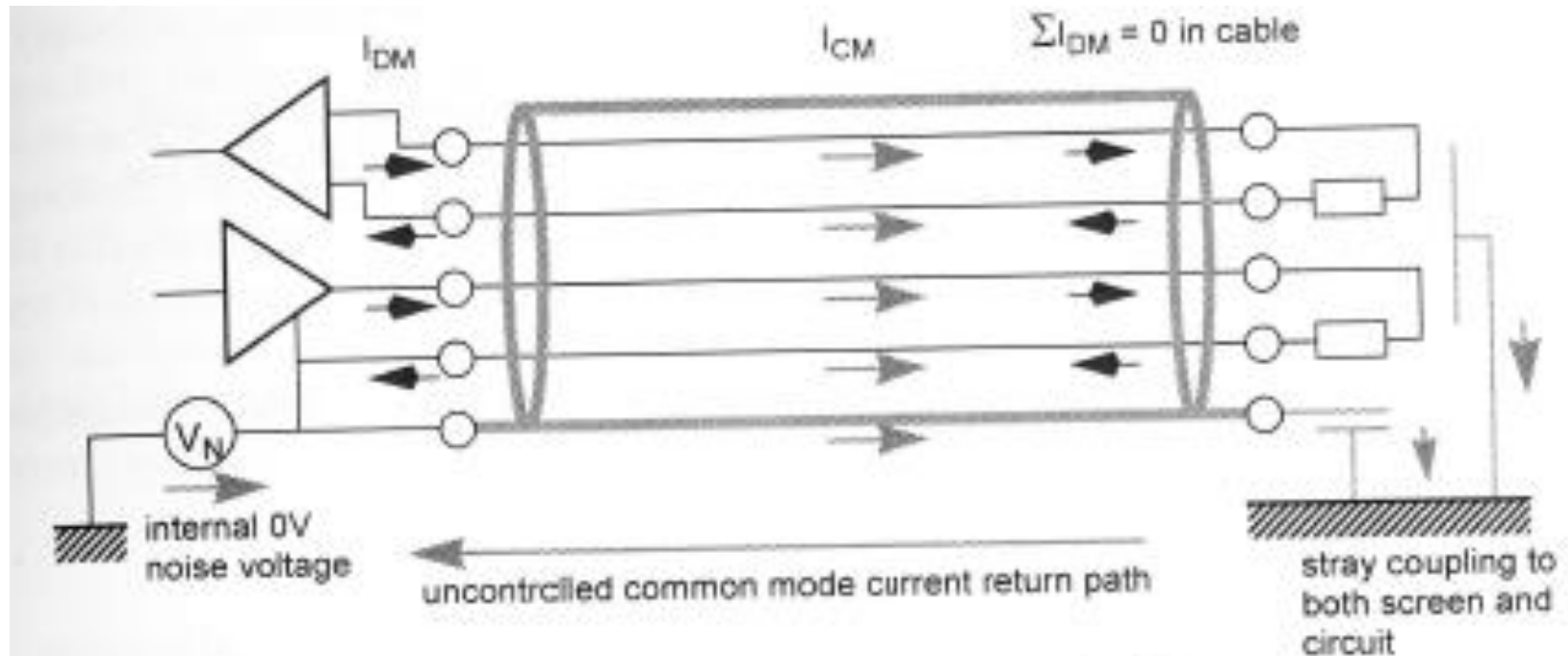
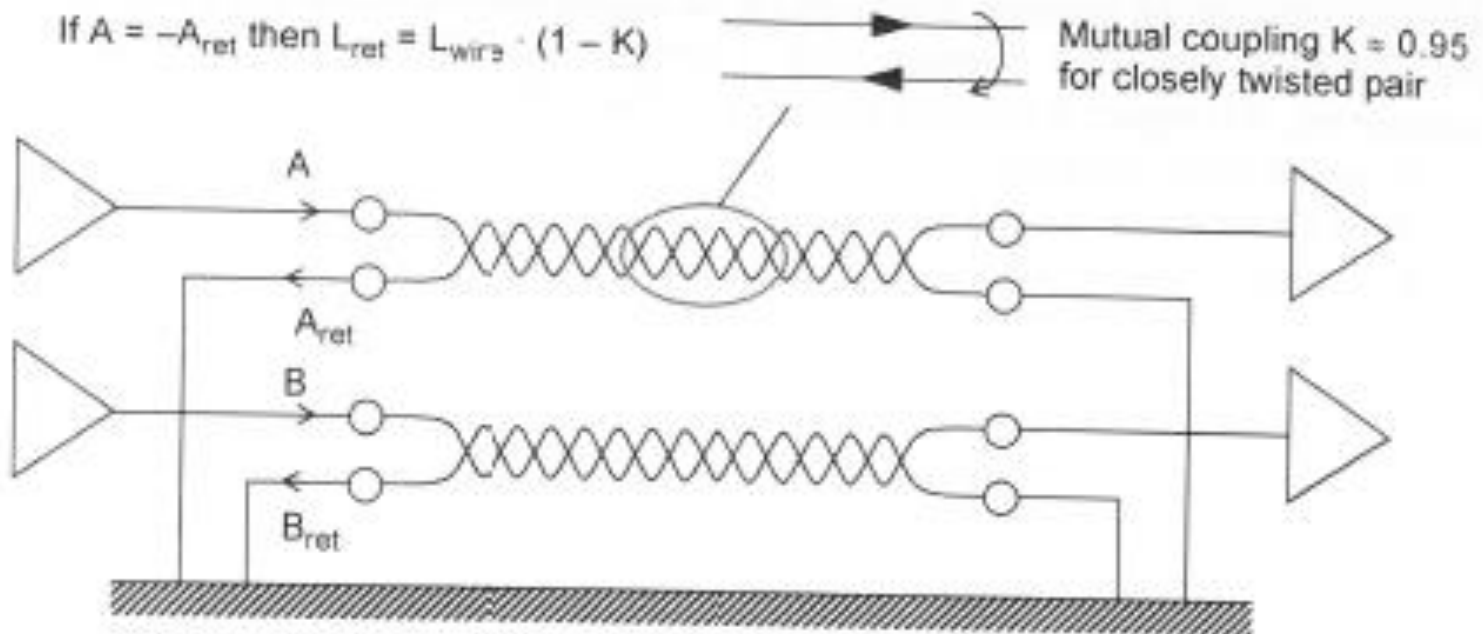

Figure 13.1 The distinction between differential and common mode cable currents

Returvägar för signalström



HF signal return currents A_{ret} and B_{ret} flow through their local twisted pair return path rather than through ground because this offers the lowest overall path inductance L_{ret}

Figure 13.2 Signal return current paths

Överhörning

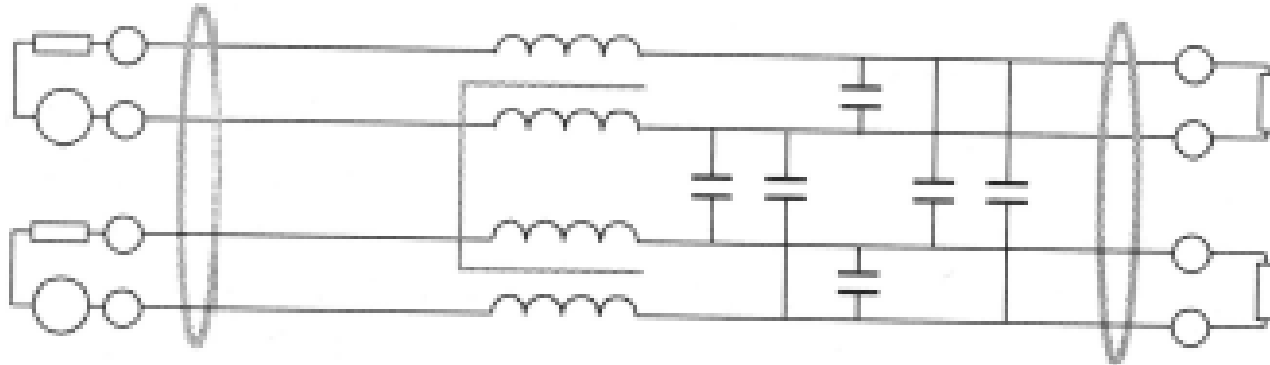

Figure 13.3 Intra-cable crosstalk

Skärmning mot kapacitiv överhörning

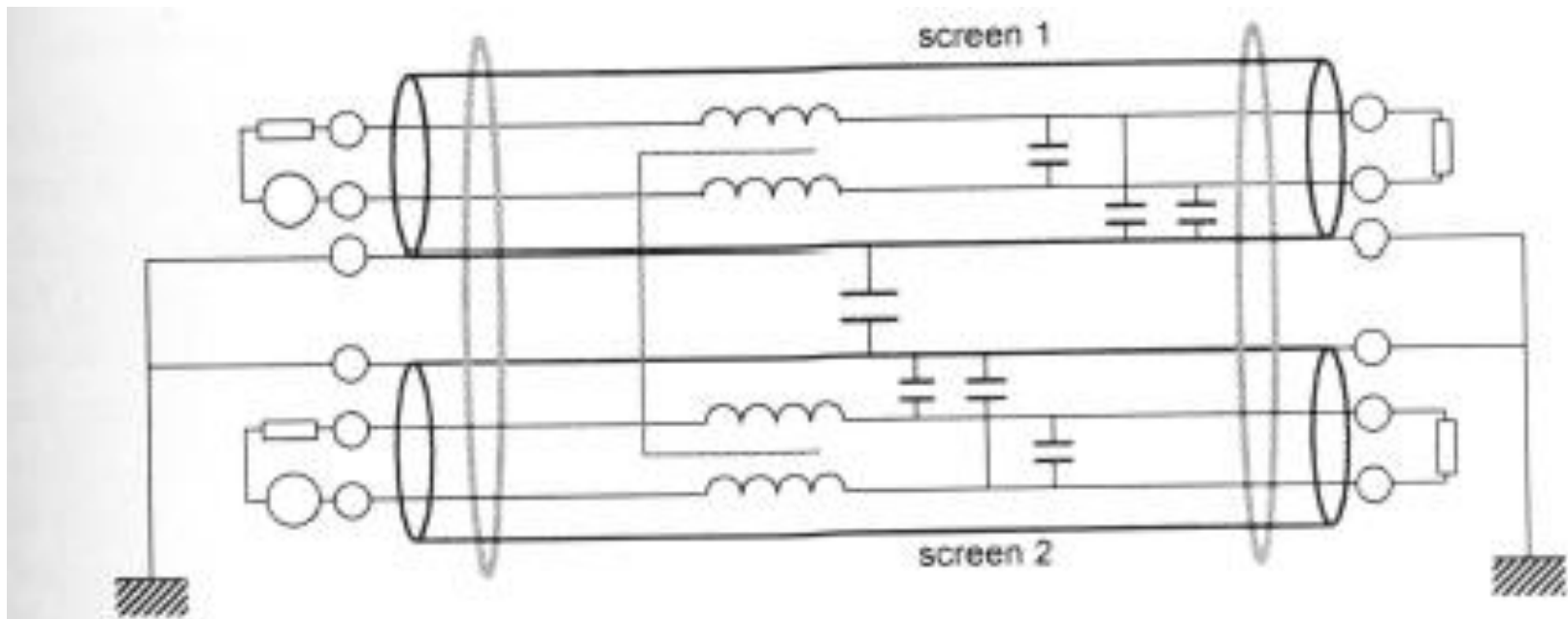
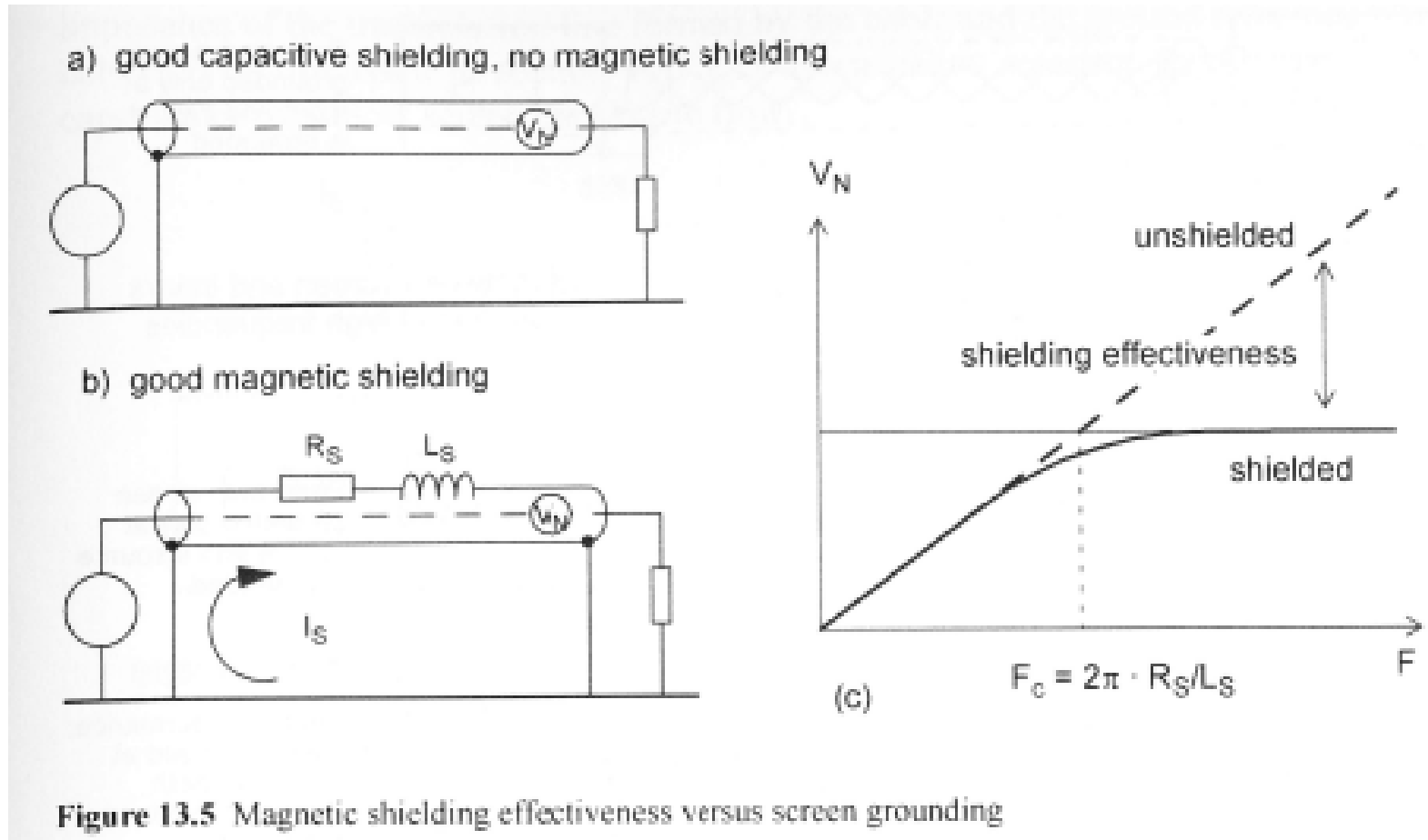

Figure 13.4 Screening against capacitive crosstalk

Magnetisk skärmning – jordning av skärm



Jordning av skärm

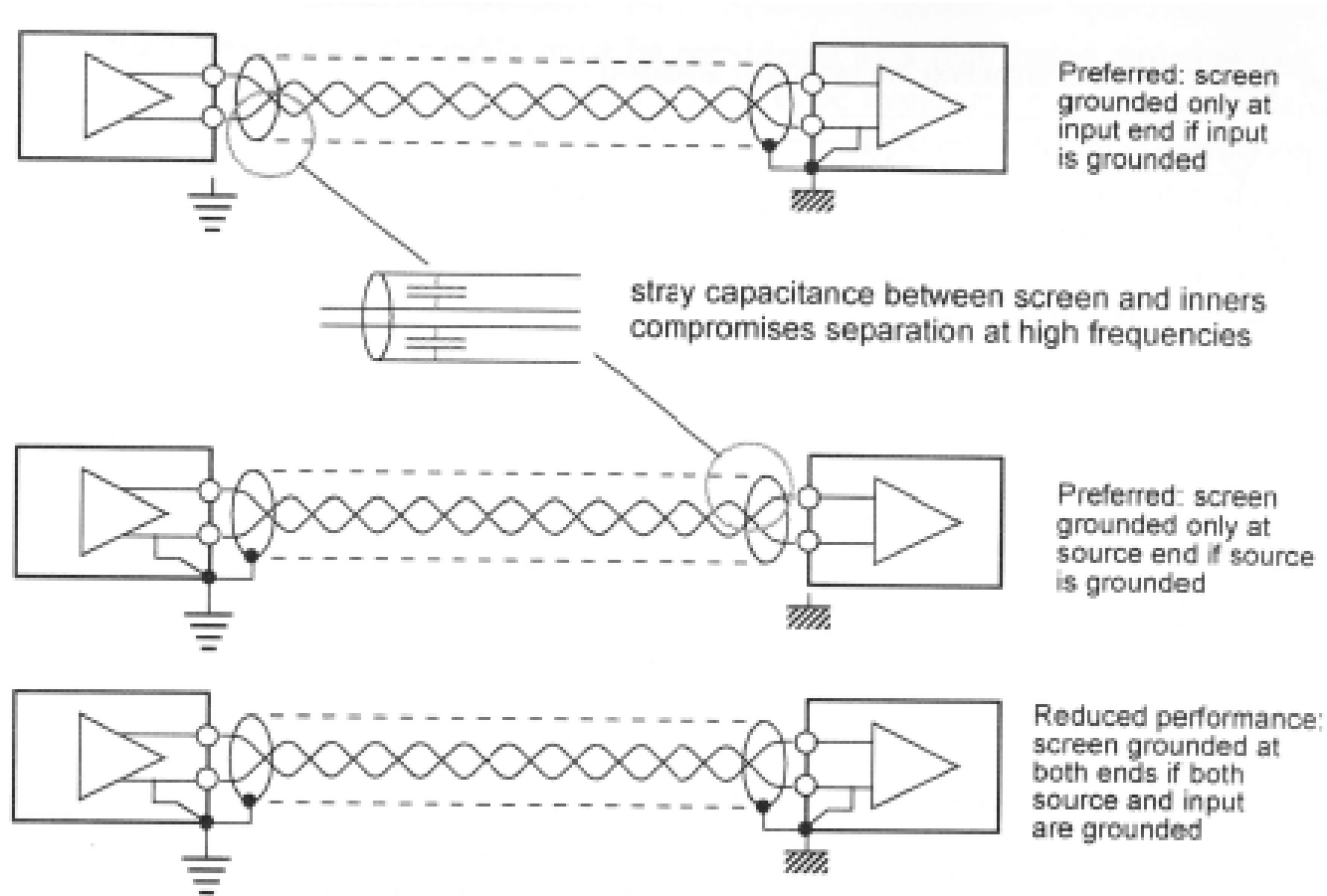

Figure 13.6 Screen grounding arrangements versus circuit configuration

Kabelskärm vid RF

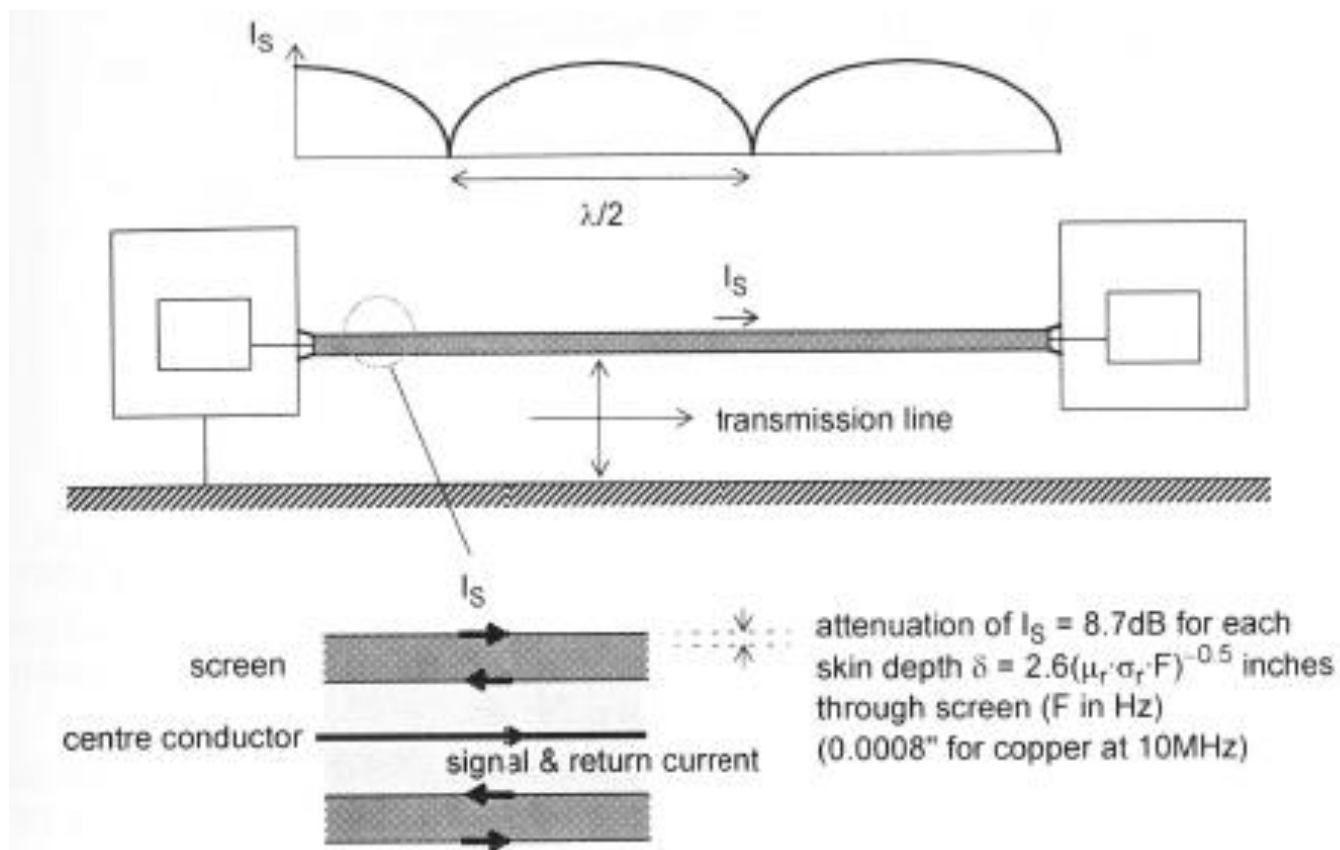

Figure 13.7 The cable screen at RF

Vanliga kabelskärmar

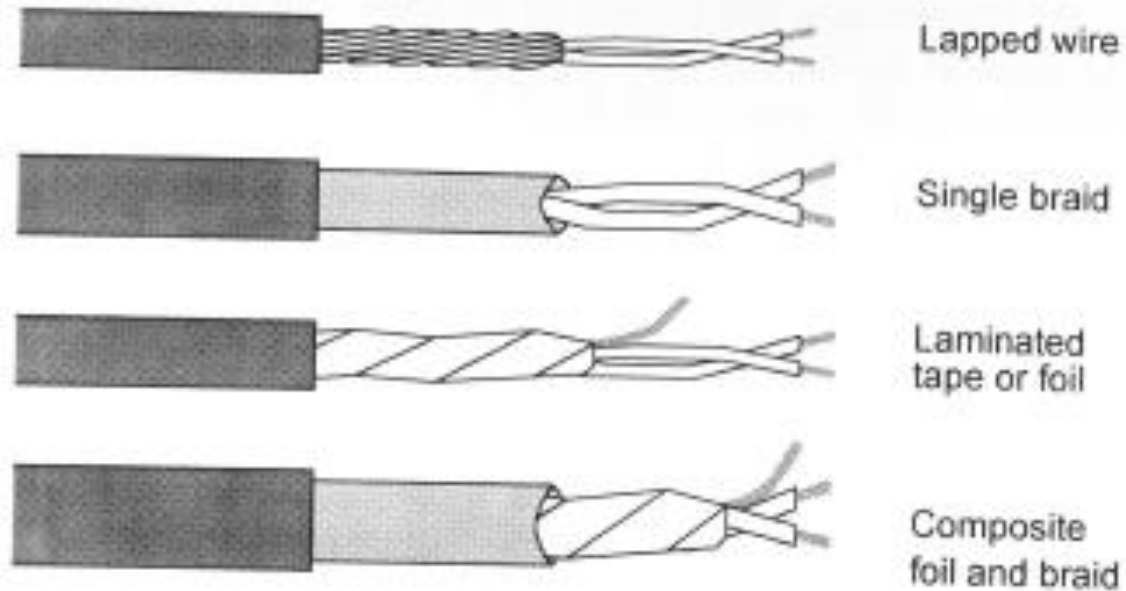
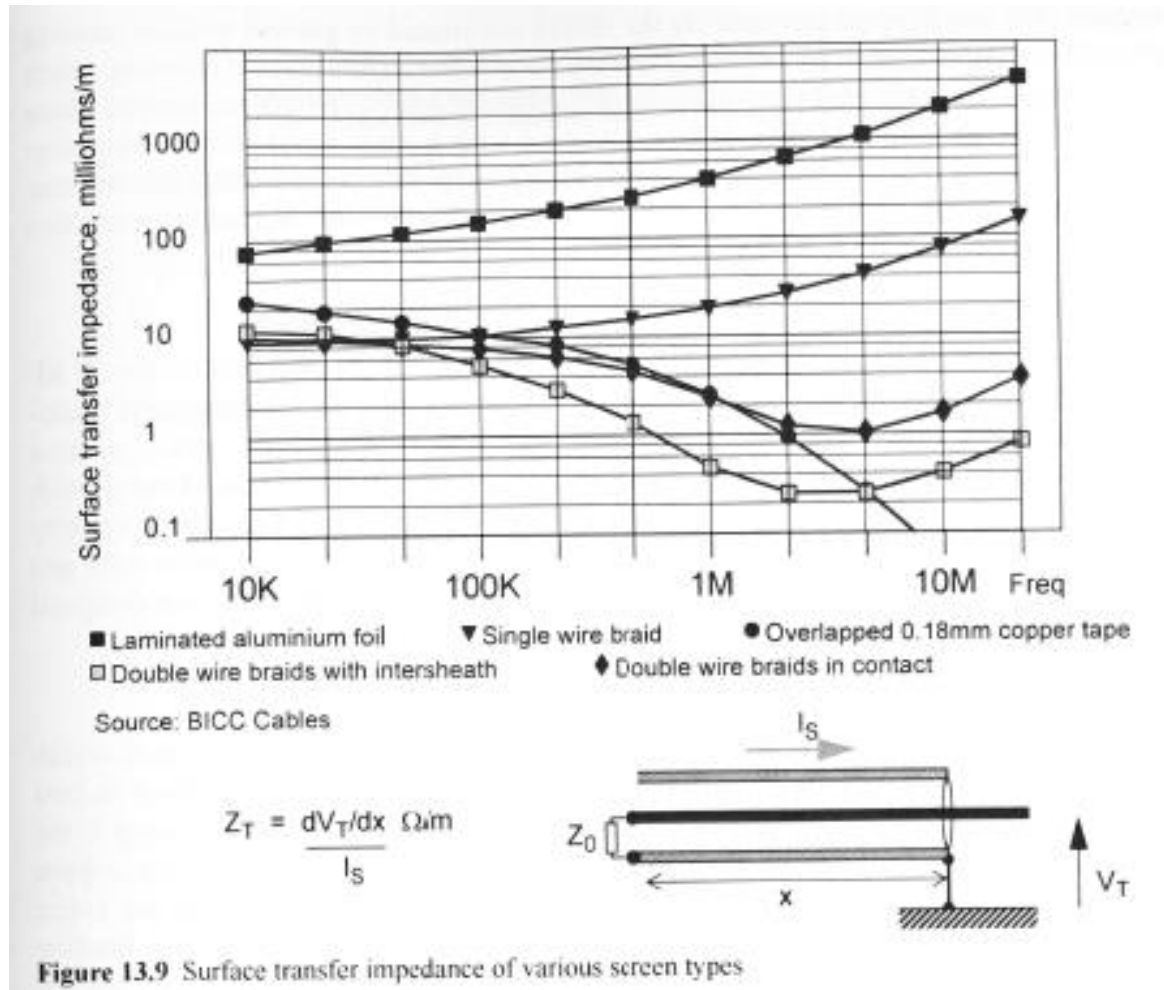
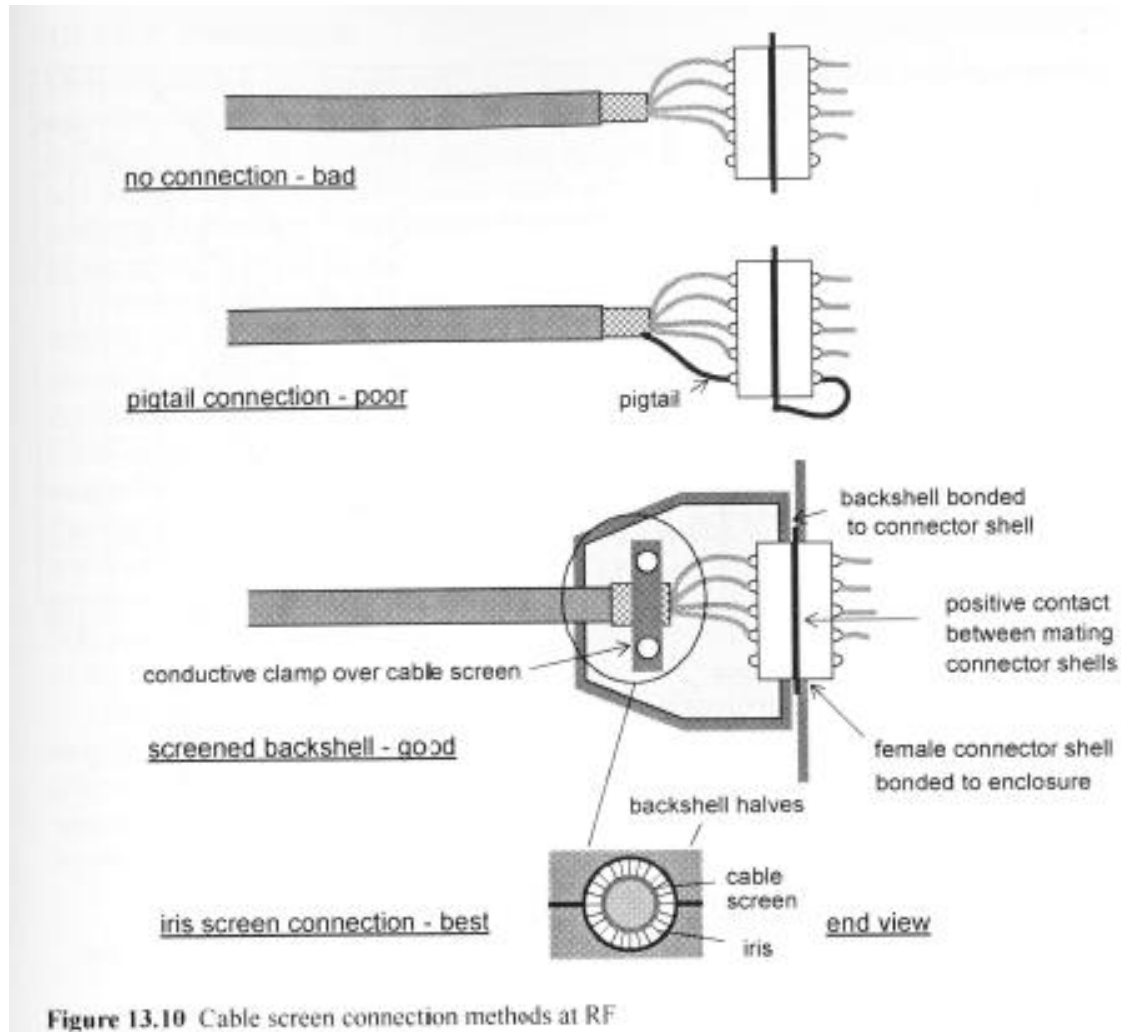

Figure 13.8 Common screen types

Olika typer av skärm



Jordning av skärm, RF



Pigtail

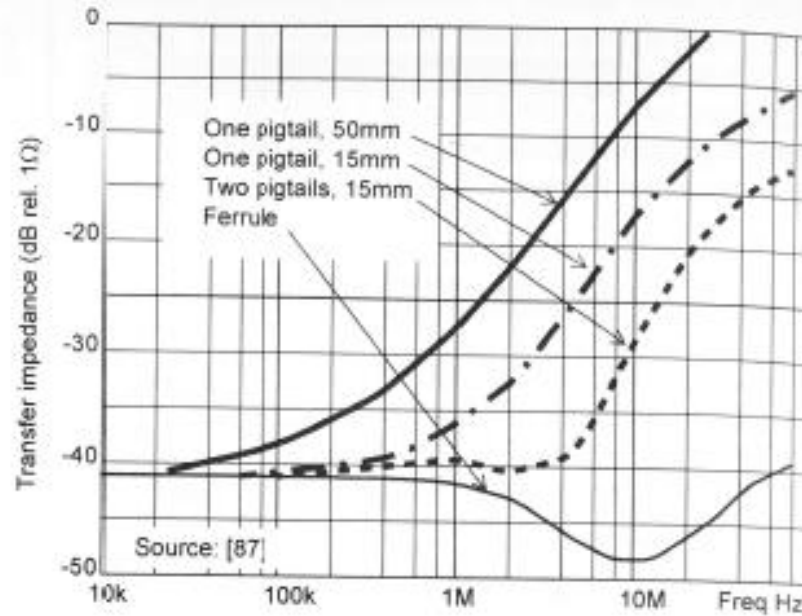
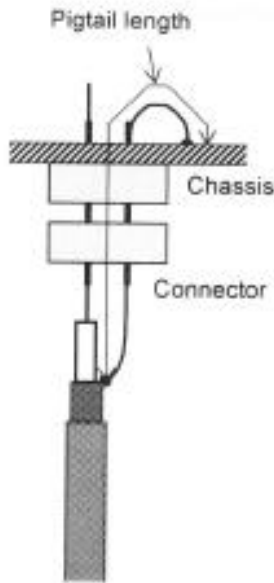

no c-m voltage differential at interface

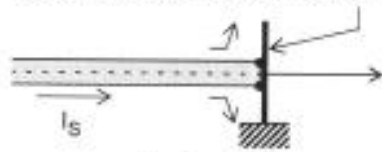

without pigtail

c-m voltage differential = $L_p \cdot di_S/dt$

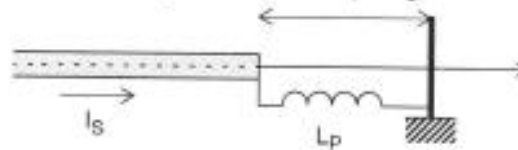

with pigtail

Figure 13.11 The bane of the pigtail

Twisted pair

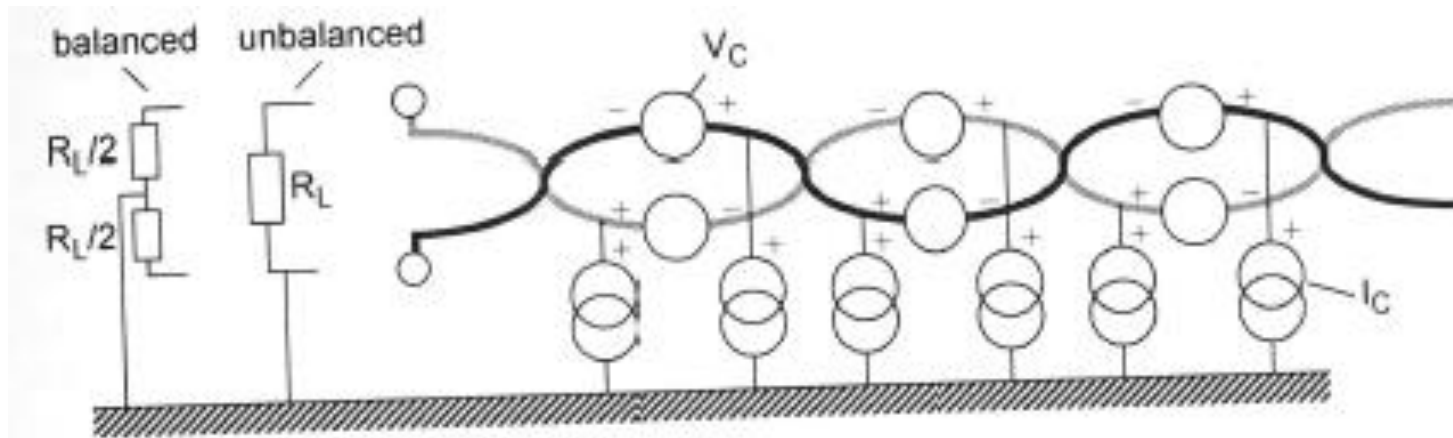
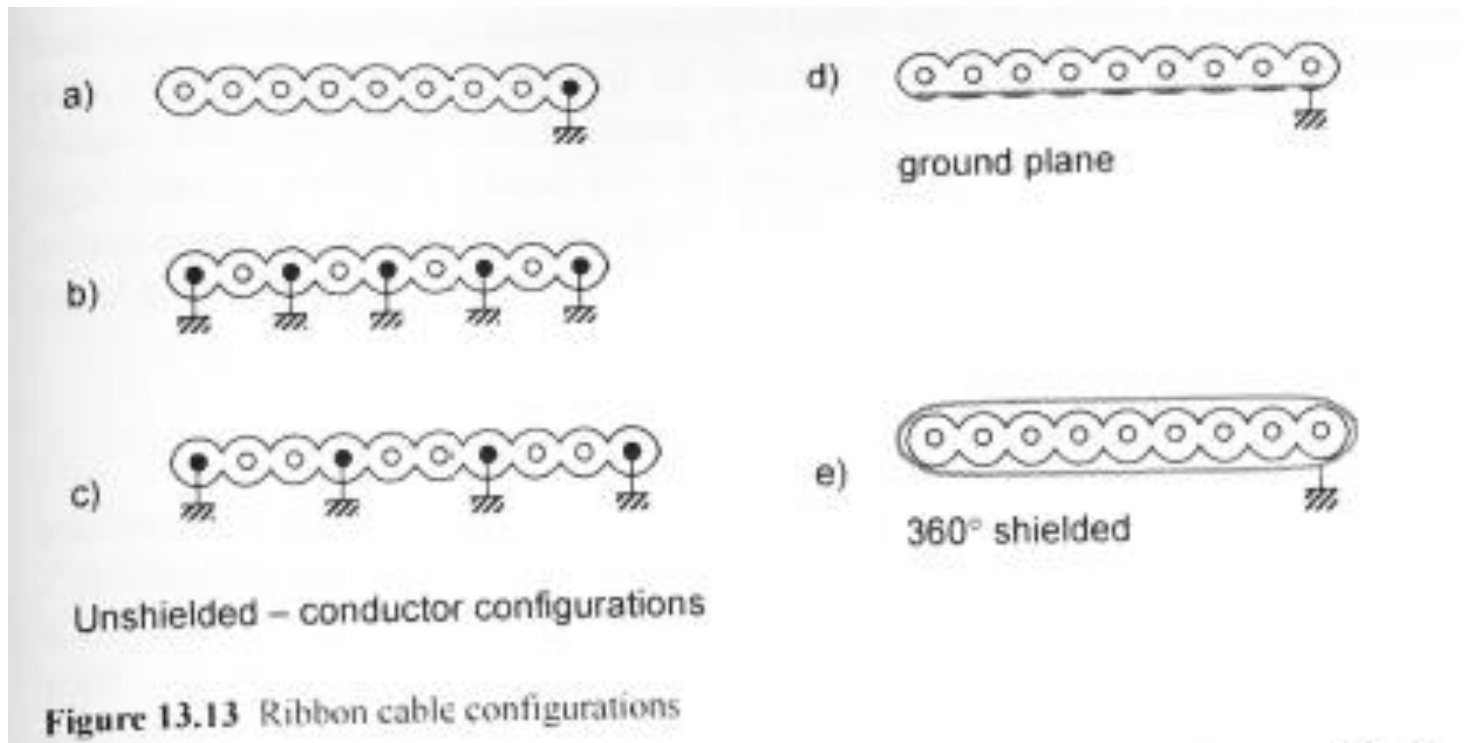

Figure 13.12 Equivalent circuit for coupling to twisted pair

Jordning flatkabel



Filterconfiguration

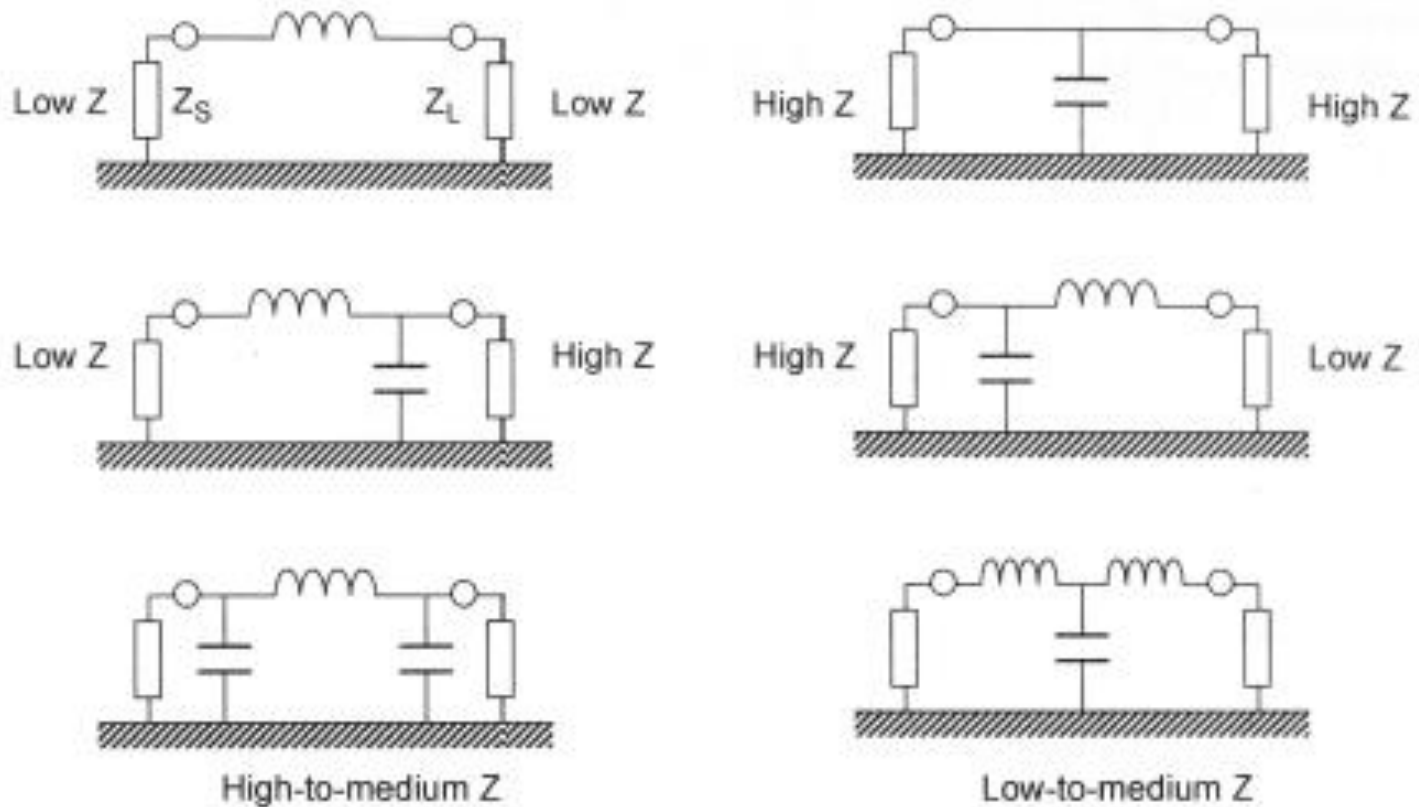
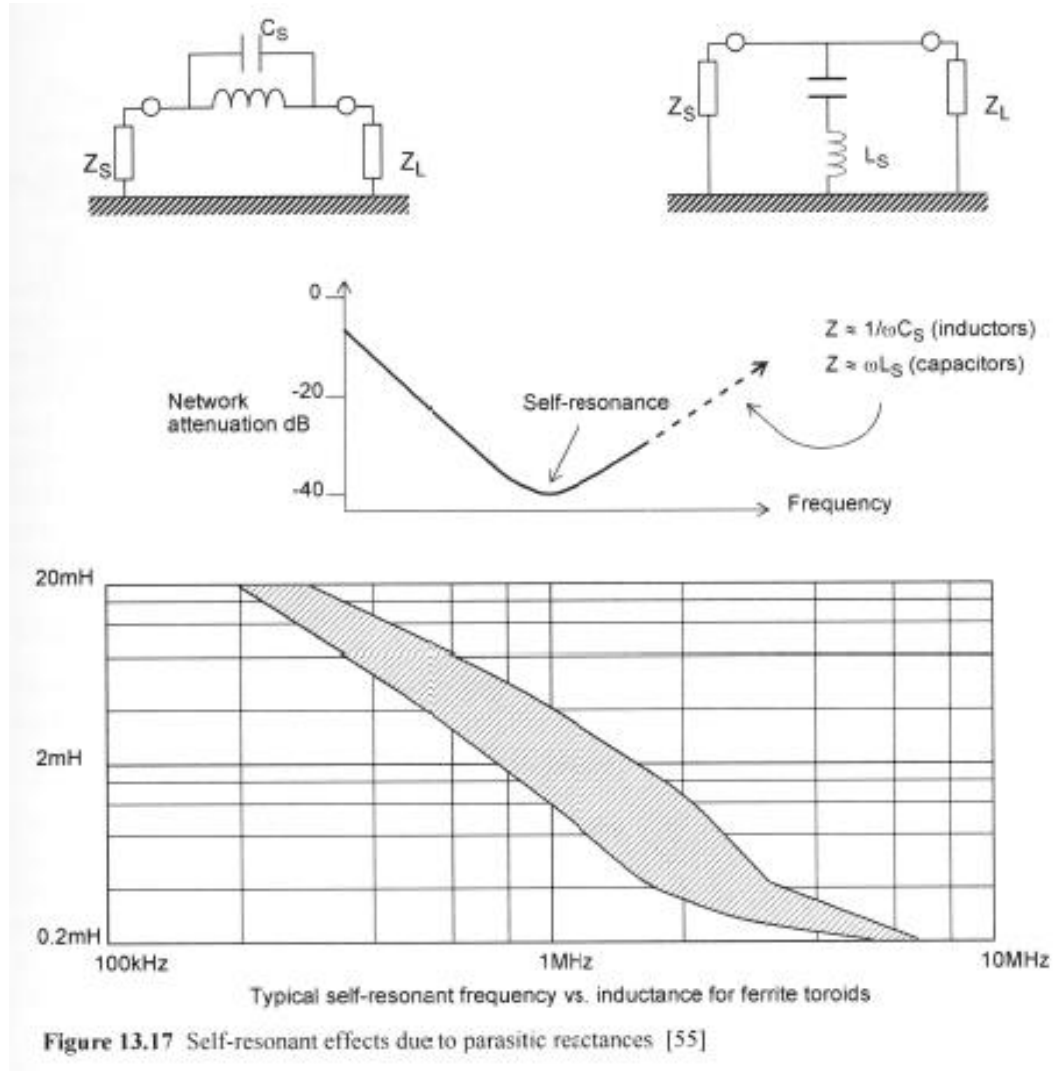

Figure 13.16 Filter configuration versus impedance

Parasitreaktanser



Lindning av spolar

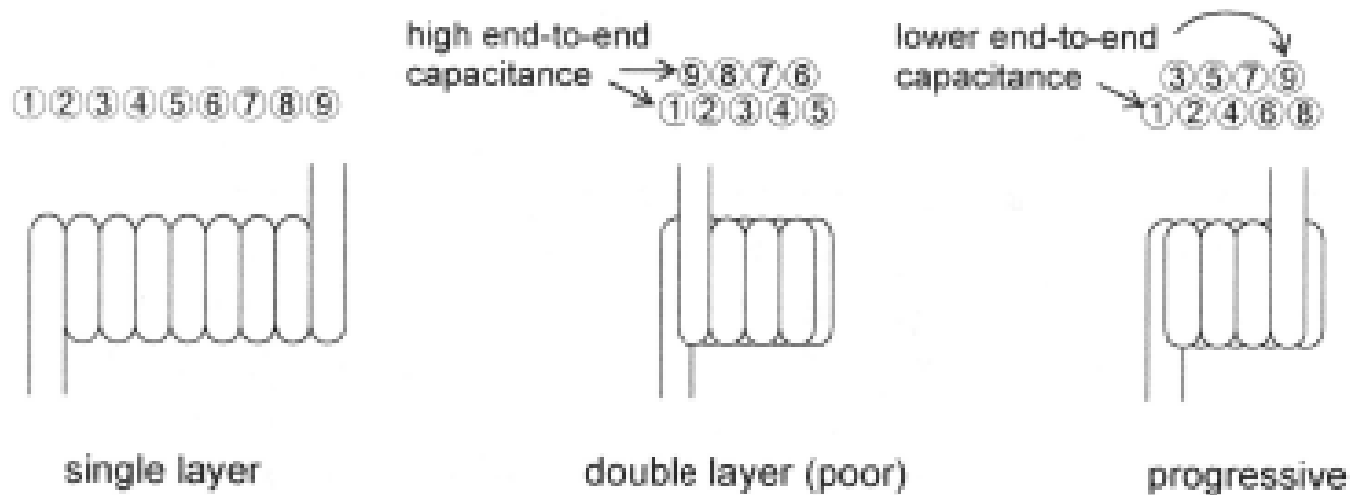
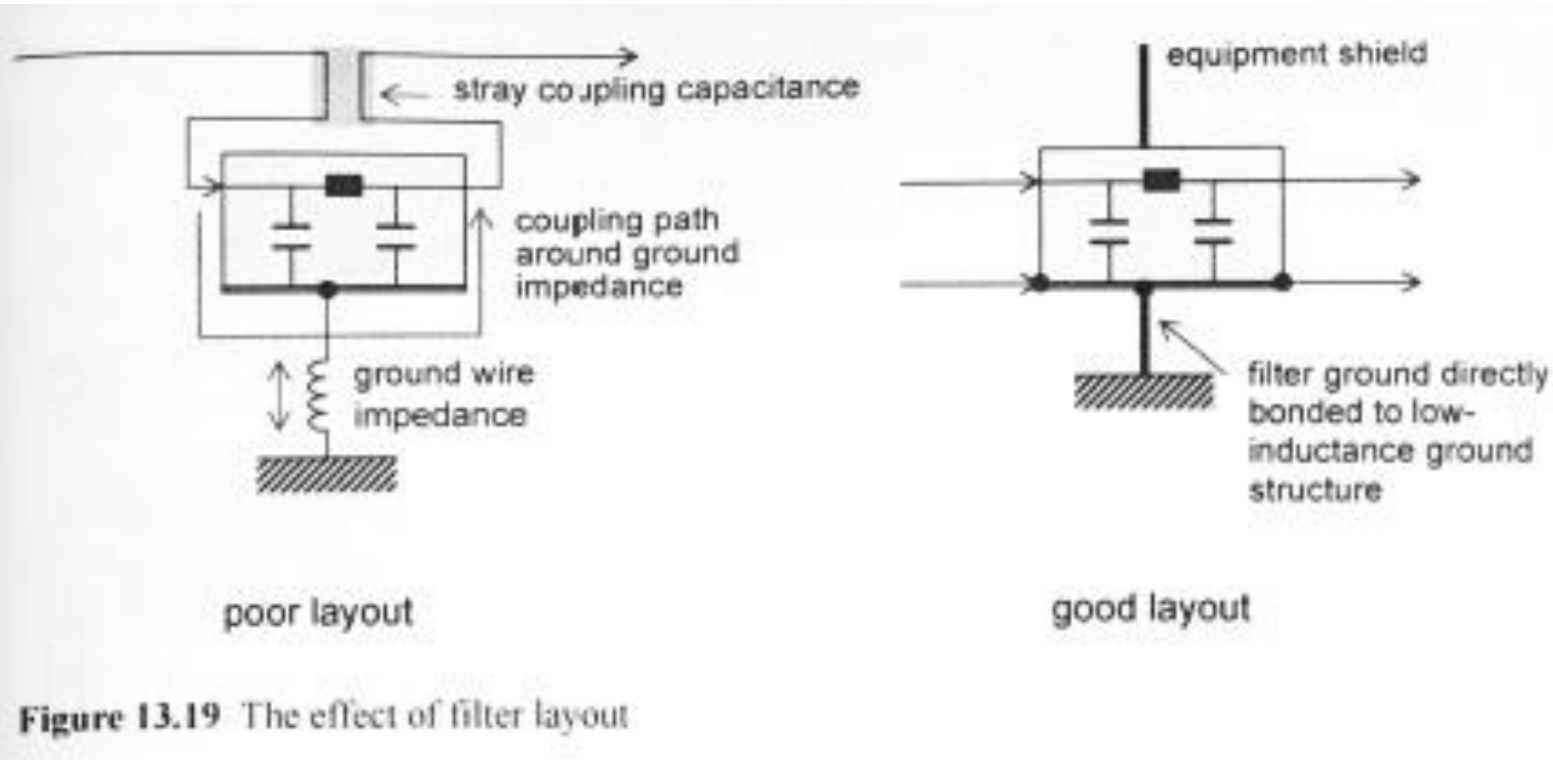
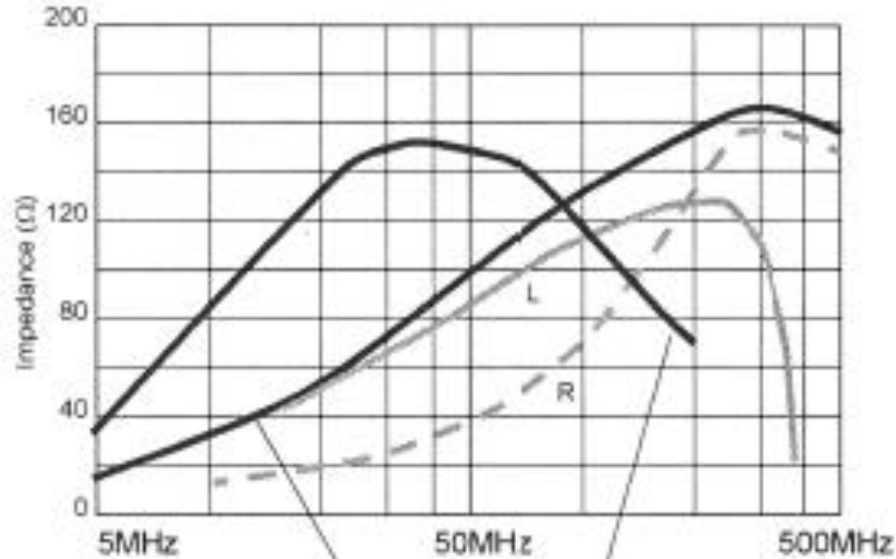

Figure 13.18 Inductor winding techniques



Ferriter



different material compositions

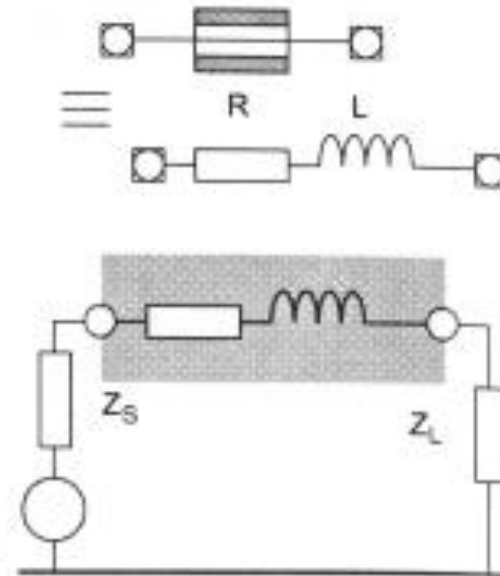

simplified equivalent circuit

Figure 13.20 Ferrite impedance versus frequency and equivalent circuit

Kondensator med tre anslutningar

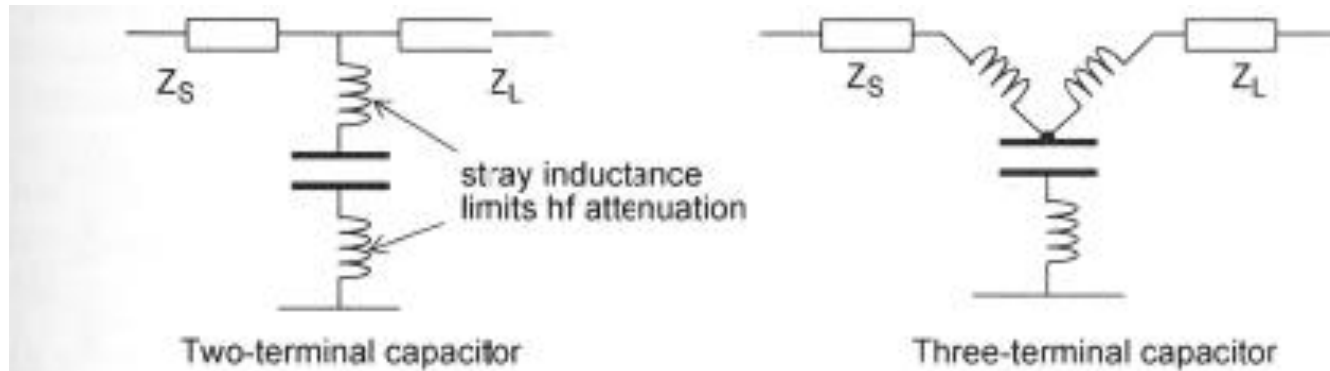

Figure 13.22 The three-terminal capacitor

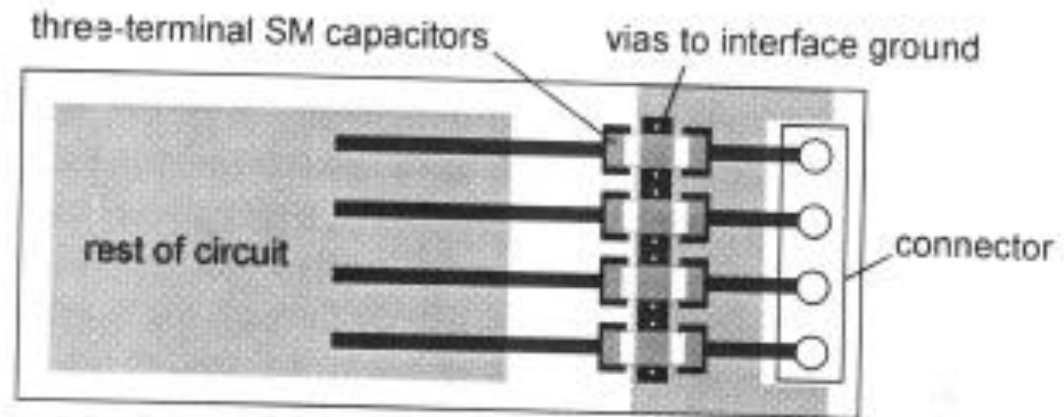

Figure 13.23 Using three-terminal surface mount capacitors

Filtrering av nätspänning

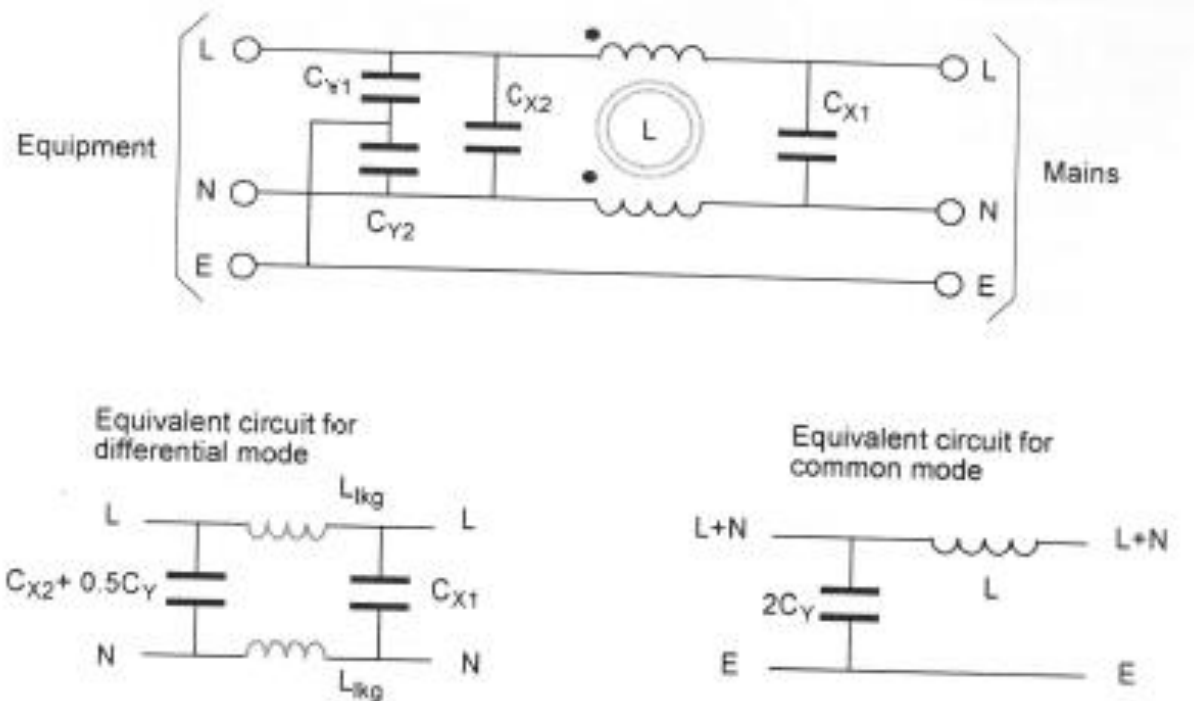

Figure 13.25 Typical mains filter and its equivalent circuit

Common mode choke

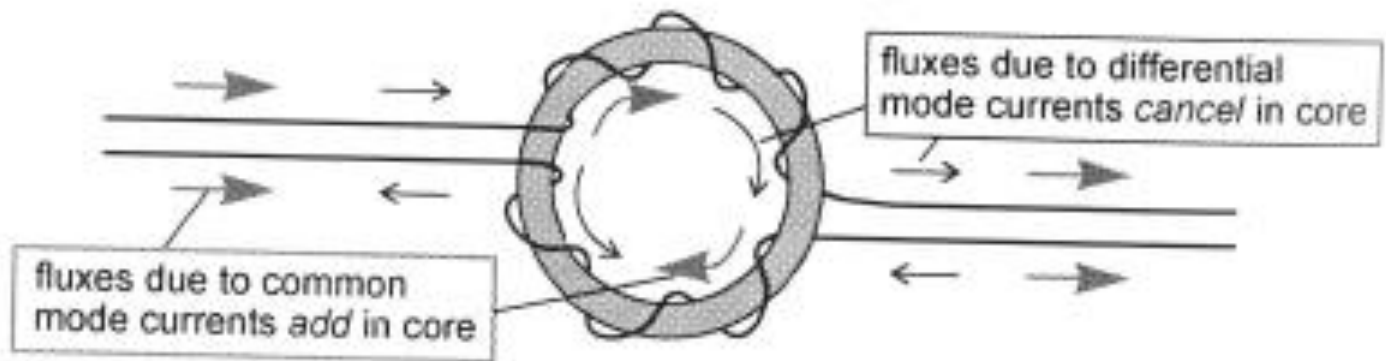

Figure 13.26 The common mode choke