

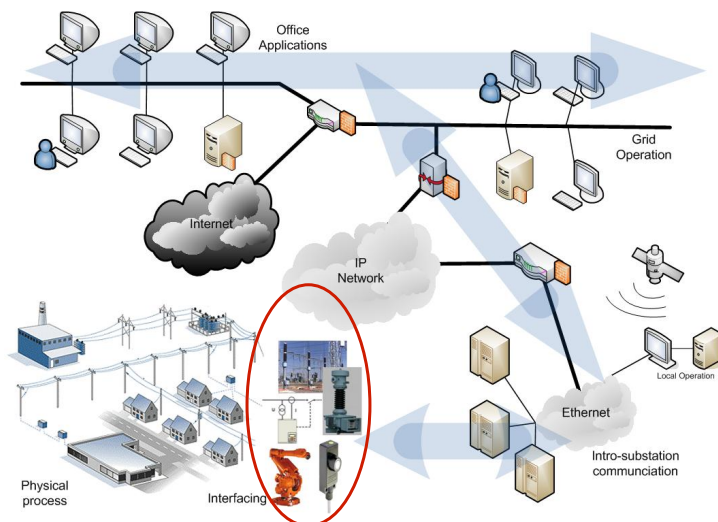

Lecture 3 Power System Measurement

Course map





Outline of the Lecture

- Instrument Transformers *(NPAG Ch. 6)*
 - Voltage Transformer
 - Current Transformers
- Measurement Setups
- Transducers *(NPAG Ch. 22)*

3



The Current Transformer (CT)



High Voltage



Bushing type
Medium Voltage



Medium Voltage

4



CT – General Types

- Wound primary
 - Traditional transformer with secondary and primary windings
- Bar primary
 - The primary winding is a single bar, that passes through a core with the secondary winding.

5



CT – Principle of Operation

- Traditional Electromagnetic transformer
- $I_s = I_p \cdot N_p / N_s$
- Normally Bar type CTs are used

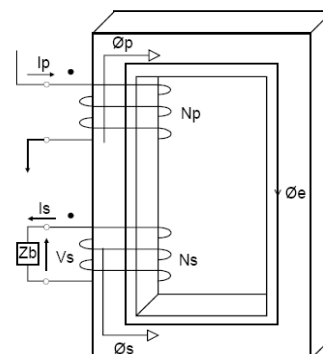

6



CT – Equivalent Model

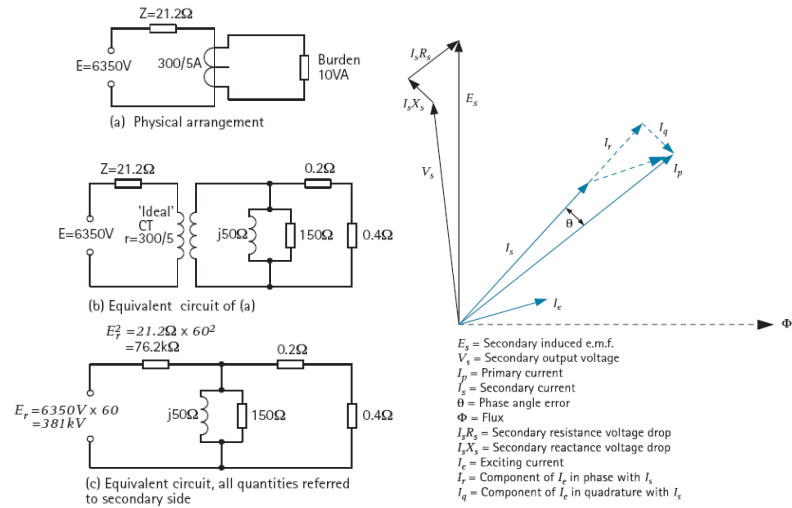

7



CTs Accuracy

Accuracy class	% current	+/- Percentage current (ratio) error				+/- Phase displacement (minutes)			
		5	20	100	120	5	20	100	120
0.1		0.4	0.2	0.1	0.1	15	8	5	5
0.2		0.75	0.35	0.2	0.2	30	15	10	10
0.5		1.5	0.75	0.5	0.5	90	45	30	30
1		3	1.5	1.0	1.0	180	90	60	60

(a) Limits of error accuracy for error classes 0.1 - 1.0

Accuracy class	+/- current (ratio) error, %	
	50	120
3	3	3
5	5	5

(b) Limits of error for error classes 3 and 5

Table 6.4: CT error classes

8

Voltage Transformers (VT)

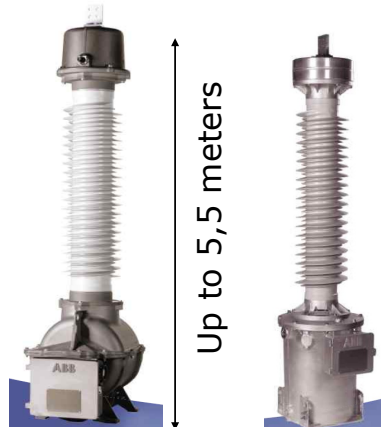

High Voltage

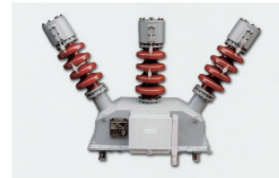

Medium Voltage
< 36kV

9

VT – General Types



- Electromagnetic type
 - Commonly referred to as VT
 - Traditional Electromagnetic transformer
 - Used up to approx 130kV
 - Thereafter insulation problems arise
- Capacitor Type
 - Commonly referred to as CVT
 - Series coupled capacitors
 - Used up to EHV/UHV levels

10

VT – Principle of Operation



- Traditional Electromagnetic transformer
- $V_s = V_p \cdot N_s / N_p$
- Connected either
 - Phase - Earth
 - Phase - Phase
- Single-pole
 - Star coupled

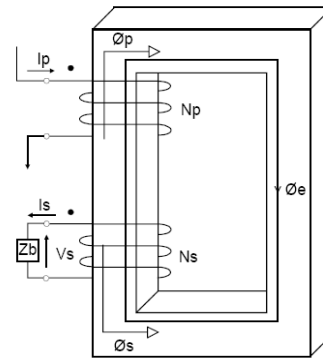

Equivalent Model

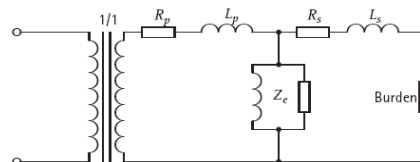
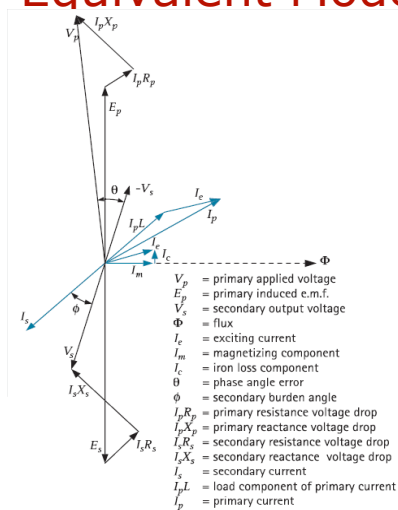



CVT – Principle of Operation

- Basic potential divider
- Inductive compensation to cancel effect of capacitive source impedance
- To reduce the size of capacitors, a VT is added on output side.

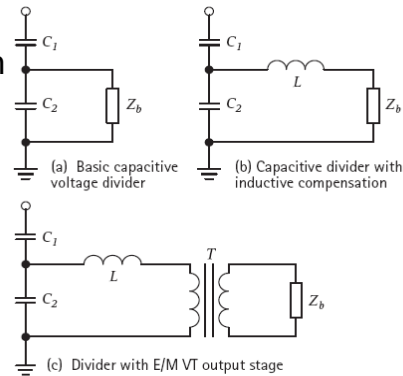

13



VT – Design Factors

- Electromagnetic VT
 - Flux density in core well below saturation
 - Output design ranges 200-300 VA
 - Insulation larger volume than windings
- Capacitive VTs
 - More space conserving
 - May include a VT
 - Can be used for overloading High-Frequency signals on Power Line.

14



VT Connection

- VTs are single pole above 36 kV
- CVTs
 - Phase to Earth
- VTs
 - Phase to Phase, Phase to Earth
 - Star coupling



VT - Accuracy

- Accuracy classes for measurement & revenue metering
- Accuracy classes for protection

Accuracy class	0.8 - 1.2 x rated voltage 0.25 - 1.0 x rated burden at 0.8pf	
	voltage ratio error (%)	phase displacement (minutes)
0.1	+/- 0.1	+/- 5
0.2	+/- 0.2	+/- 10
0.5	+/- 0.5	+/- 20
1.0	+/- 1.0	+/- 40
3.0	+/- 3.0	not specified

Table 6.1: Measuring voltage transformer error limits

Accuracy class	0.25 - 1.0 x rated burden at 0.8pf 0.05 - V_f x rated primary voltage	
	voltage ratio error (%)	phase displacement (%)
3P	+/- 3.0	+/- 120
6P	+/- 6.0	+/- 240

Table 6.2: Additional limits for protection voltage transformers.



Summary - VTs/CTs

- VTs and CTs are the primary measurement method for medium and high voltage
- Important design characteristics are
 - Accuracy for revenue metering
 - Linearity for protection
 - Size = cost
- The output is further transformed using transducers.

17



Contents of the Lecture

- Instrument Transformers *(NPAG Ch. 6)*
 - Voltage Transformer
 - Current Transformers
- Measurement Setups
- Transducers *(NPAG Ch. 22)*

18



What do we need to measure?

- Voltage V
- Current I
- Frequency f
- Phase angle ϕ
- Power Q, P
- Position on/off
-

19



Current Measurement

- Connected to secondary side of CT
- Cannot sense direction
- Measurement types
 - Mean sensing
 - r.m.s. measurement

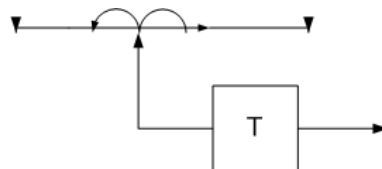

20

Voltage Measurement

- Connected to secondary of VT/CVT

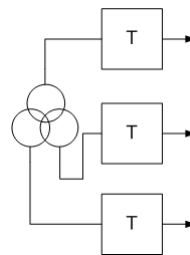

21

Phase Angle Measurement

- Implemented using zero-crossing detection
- Sensitive to harmonics
- Connected to phases and quantities (U or I) as needed for measurement

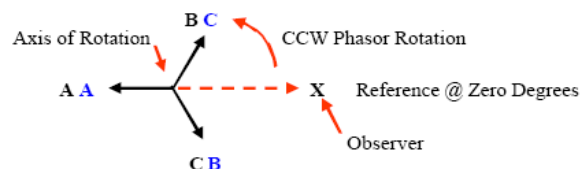

22



Frequency Measurement

- Important for system operation
- Analog – Digital conversion
 - Fourier Transform for f analysis
- Accuracy up to 0,01% available, +/- 5 mHz
- Connected to VT or CT secondary

23



Power Measurement

- Measurement of P & Q
 - Many configurations available
 - Direction of the flow important

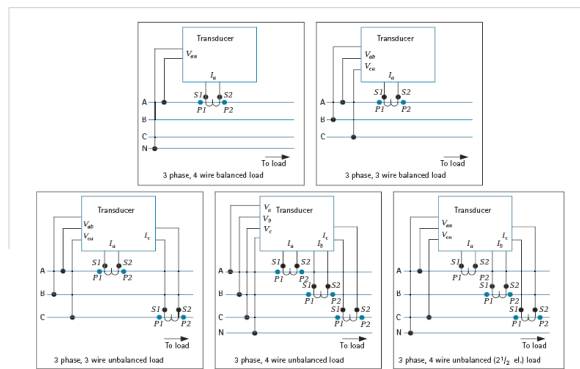

24



Outline of the Lecture

- Instrument Transformers *(NPAG Ch. 6)*
 - Voltage Transformer
 - Current Transformers
- Measurement Setups.
- Transducers *(NPAG Ch. 22)*

25



Wiring & Communication

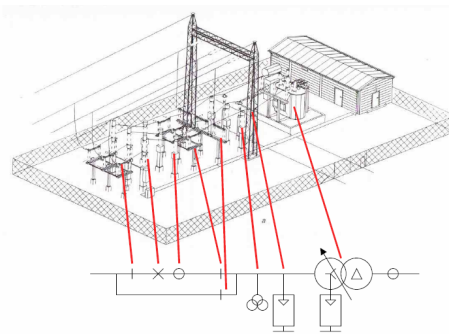

Source: Lakervi & Holmes

26



Transducers

- A transducer is a device, usually electrical, electronic, or electro-mechanical, that converts one type of energy to another for various purposes including measurement or information transfer. In a broader sense, a transducer is sometimes defined as any device that converts a signal from one form to another.

www.wikipedia.org

27



Benefits of using transducers

- Reduces the burden on instrument transformers
- Ability to mount display equipment remote from the measurement point
- Ability to use multiple display units per measurement point
- Reducing need for long wiring from instrument transformers



28

Transducer types



- Analog or Digital transducers
- Digital transducers (A/D conversion)
 - Benefits
 - Improved long-term stability
 - More accurate r.m.s measurement
 - Improved Communications
 - Programmable scaling
 - Reduced size
 - Wider range of functions
 - Output normally a RS-485 or 232 interface

29

Equivalent Model (analog)



- Output from a transducer normally a current source
- E.g. 4-20 mA as a function of input

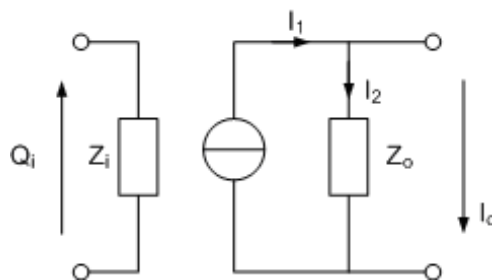

30

A/D conversion

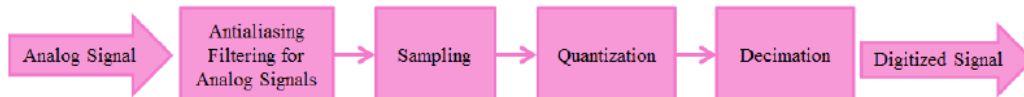

- Accuracy determined by
 - Bit resolution, Least Significant Bit
 - Non-linearity due to imperfections.
 - Sampling & Aliasing

31

Sampling & Aliasing

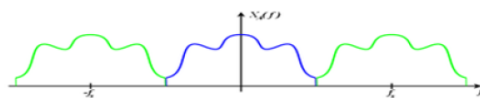
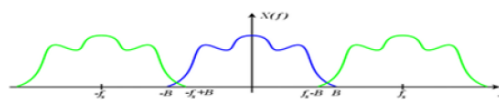
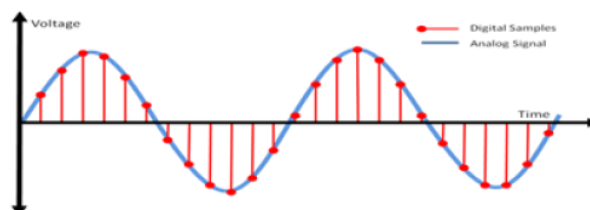

32



A/D - Quantization

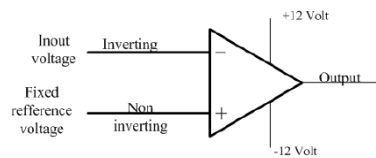

- Base circuit is the comparator
- If Input > Vref output = V+
- If Input < Vref = Output = V-

33



Flash ADC

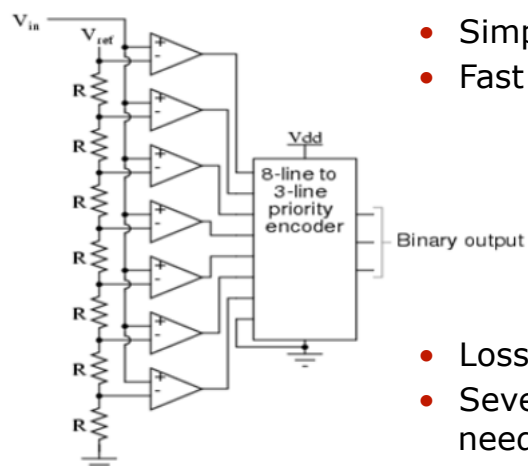

- Simple concept
- Fast
- Losses increase
- Several comparators needed
- Low resolution

34

Further AD-Converter types



- Integrator
 - Integrating signal applied to input of comparator and reference
- Sigma Delta
 - Oversampling of the input, and successive stages of comparison and summing.
- Accuracy still determined by
 - Bit resolution, Least Significant Bit
 - Non-linearity due to imperfections.
 - Sampling & Aliasing

35



Questions or comments?

36