

Contents

Articles

Wikibooks:Collections/Embedded Systems	1
Wikibooks:Collections Preface	3
Embedded Systems/Embedded Systems Introduction	4
Embedded Systems/Terminology	8

Microprocessor Basics **11**

Embedded Systems/Microprocessor Introduction	11
Embedded Systems/Embedded System Basics	12
Embedded Systems/Microprocessor Architectures	14
Embedded Systems/Programmable Controllers	17
Embedded Systems/Floating Point Unit	19
Embedded Systems/Parity	21
Embedded Systems/Memory	22
Embedded Systems/Memory Units	25

Programming Embedded Systems **26**

Embedded Systems/C Programming	26
Embedded Systems/Assembly Language	32
Embedded Systems/Mixed C and Assembly Programming	33
Embedded Systems/IO Programming	38
Embedded Systems/Serial and Parallel IO	39
Embedded Systems/Super Loop Architecture	41
Embedded Systems/Protected Mode and Real Mode	42
Embedded Systems/Bootloaders and Bootsectors	43
Embedded Systems/Terminate and Stay Resident	44

Real Time Operating Systems **45**

Embedded Systems/Real-Time Operating Systems	45
Embedded Systems/Threading and Synchronization	47
Embedded Systems/Interrupts	50
Embedded Systems/RTOS Implementation	51
Embedded Systems/Locks and Critical Sections	53
Embedded Systems/Common RTOS	56
Embedded Systems/Common RTOS/Palm OS	58

Embedded Systems/Common RTOS/Windows CE	59
Embedded Systems/Common RTOS/DOS	59
Embedded Systems/Linux	60
Interfacing	63
Embedded Systems/Interfacing Basics	63
Embedded Systems/External ICs	64
Embedded Systems/Low-Voltage Circuits	64
Embedded Systems/High-Voltage Circuits	66
Particular Microprocessor Families	68
Embedded Systems/Particular Microprocessors	68
Embedded Systems/Intel Microprocessors	71
Embedded Systems/PIC Microcontroller	72
Embedded Systems/8051 Microcontroller	77
Embedded Systems/Freescale Microcontrollers	80
Embedded Systems/Atmel AVR	82
Embedded Systems/ARM Microprocessors	99
Embedded Systems/AT91SAM7S64	100
Embedded Systems/Cypress PSoC Microcontroller	100
Appendices	106
Embedded Systems/Common Protocols	106
Embedded Systems/Where To Buy	107
Embedded Systems/Resources	108
Embedded Systems/Licensing	110
References	
Article Sources and Contributors	111
Image Sources, Licenses and Contributors	113
Article Licenses	
License	114

Wikibooks:Collections/Embedded Systems

Embedded Systems

Building and Programming Embedded Devices

Wikibooks:Collections Preface

Embedded Systems/Embedded Systems Introduction

Embedded Systems/Terminology

Microprocessor Basics

Embedded Systems/Microprocessor Introduction

Embedded Systems/Embedded System Basics

Embedded Systems/Microprocessor Architectures

Embedded Systems/Programmable Controllers

Embedded Systems/Floating Point Unit

Embedded Systems/Parity

Embedded Systems/Memory

Embedded Systems/Memory Units

Programming Embedded Systems

Embedded Systems/C Programming

Embedded Systems/Assembly Language

Embedded Systems/Mixed C and Assembly Programming

Embedded Systems/IO Programming

Embedded Systems/Serial and Parallel IO

Embedded Systems/Super Loop Architecture

Embedded Systems/Protected Mode and Real Mode

Embedded Systems/Bootloaders and Bootsectors

Embedded Systems/Terminate and Stay Resident

Real Time Operating Systems

Embedded Systems/Real-Time Operating Systems

Embedded Systems/Threading and Synchronization

Embedded Systems/Interrupts

Embedded Systems/RTOS Implementation

Embedded Systems/Locks and Critical Sections

Embedded Systems/Common RTOS

Embedded Systems/Common RTOS/Palm OS

Embedded Systems/Common RTOS/Windows CE

Embedded Systems/Common RTOS/DOS

Embedded Systems/Linux

Interfacing

[Embedded Systems/Interfacing Basics](#)

[Embedded Systems/External ICs](#)

[Embedded Systems/Low-Voltage Circuits](#)

[Embedded Systems/High-Voltage Circuits](#)

Particular Microprocessor Families

[Embedded Systems/Particular Microprocessors](#)

[Embedded Systems/Intel Microprocessors](#)

[Embedded Systems/PIC Microcontroller](#)

[Embedded Systems/8051 Microcontroller](#)

[Embedded Systems/Freescale Microcontrollers](#)

[Embedded Systems/Atmel AVR](#)

[Embedded Systems/ARM Microprocessors](#)

[Embedded Systems/AT91SAM7S64](#)

[Embedded Systems/Cypress PSoC Microcontroller](#)

Appendices

[Embedded Systems/Common Protocols](#)

[Embedded Systems/Where To Buy](#)

Resources and Licensing

[Embedded Systems/Resources](#)

[Embedded Systems/Licensing](#)

Wikibooks:Collections Preface

This book was created by volunteers at Wikibooks (<http://en.wikibooks.org>).

What is Wikibooks?

Started in 2003 as an offshoot of the popular Wikipedia project, Wikibooks is a free, collaborative wiki website dedicated to creating high-quality textbooks and other educational books for students around the world. In addition to English, Wikibooks is available in over 130 languages, a complete listing of which can be found at <http://www.wikibooks.org>. Wikibooks is a "wiki", which means anybody can edit the content there at any time. If you find an error or omission in this book, you can log on to Wikibooks to make corrections and additions as necessary. All of your changes go live on the website immediately, so your effort can be enjoyed and utilized by other readers and editors without delay.



Books at Wikibooks are written by volunteers, and can be accessed and printed for free from the website. Wikibooks is operated entirely by donations, and a certain portion of proceeds from sales is returned to the Wikimedia Foundation to help keep Wikibooks running smoothly. Because of the low overhead, we are able to produce and sell books for much cheaper than proprietary textbook publishers can. **This book can be edited by anybody at any time, including you.** We don't make you wait two years to get a new edition, and we don't stop selling old versions when a new one comes out.

What is this book?

This book was generated by the volunteers at Wikibooks, a team of people from around the world with varying backgrounds. The people who wrote this book may not be experts in the field. Some may not even have a passing familiarity with it. The result of this is that some information in this book may be incorrect, out of place, or misleading. For this reason, you should never rely on a community-edited Wikibook when dealing in matters of medical, legal, financial, or other importance. Please see our disclaimer for more details on this.

Despite the warning of the last paragraph, however, books at Wikibooks are continuously edited and improved. If errors are found they can be corrected immediately. If you find a problem in one of our books, we ask that you **be bold** in fixing it. You don't need anybody's permission to help or to make our books better.

Wikibooks runs off the assumption that many eyes can find many errors, and many able hands can fix them. Over time, with enough community involvement, the books at Wikibooks will become very high-quality indeed. **You are invited to participate at Wikibooks to help make our books better.** As you find problems in your book don't just complain about them: Log on and fix them! This is a kind of proactive and interactive reading experience that you probably aren't familiar with yet, so log on to <http://en.wikibooks.org> and take a look around at all the possibilities. We promise that we won't bite!

Who are the authors?

The volunteers at Wikibooks come from around the world and have a wide range of educational and professional backgrounds. They come to Wikibooks for different reasons, and perform different tasks. Some Wikibookians are prolific authors, some are perceptive editors, some fancy illustrators, others diligent organizers. Some Wikibookians find and remove spam, vandalism, and other nonsense as it appears. Most wikibookians perform a combination of these jobs.

It's difficult to say who are the authors for any particular book, because so many hands have touched it and so many changes have been made over time. It's not unheard of for a book to have been edited thousands of times by hundreds of authors and editors. *You could be one of them too*, if you're interested in helping out. At the time this book was prepared for print, there have been over **' edits made by over '0** registered users. These numbers are growing every day.

Wikibooks in Class

Books at Wikibooks are free, and with the proper editing and preparation they can be used as cost-effective textbooks in the classroom or for independent learners. In addition to using a Wikibook as a traditional read-only learning aide, it can also become an interactive class project. Several classes have come to Wikibooks to write new books and improve old books as part of their normal course work. In some cases, the books written by students one year are used to teach students in the same class next year. Books written can also be used in classes around the world by students who might not be able to afford traditional textbooks.

Happy Reading!

We at Wikibooks have put a lot of effort into these books, and we hope that you enjoy reading and learning from them. We want you to keep in mind that what you are holding is not a finished product but instead a work in progress. These books are never "finished" in the traditional sense, but they are ever-changing and evolving to meet the needs of readers and learners everywhere. Despite this constant change, we feel our books can be reliable and high-quality learning tools at a great price, and we hope you agree. Never hesitate to stop in at Wikibooks and make some edits of your own. We hope to see you there one day. **Happy reading!**

Embedded Systems/Embedded Systems

Introduction

Embedded Technology is now in its prime and the wealth of knowledge available is mindblowing. However, most embedded systems engineers have a common complaint. There are no comprehensive resources available over the internet which deal with the various design and implementation issues of this technology. Intellectual property regulations of many corporations are partly to blame for this and also the tendency to keep technical know-how within a restricted group of researchers.

Before embarking on the rest of this book, it is important first to cover exactly what embedded systems are, and how they are used. This wikibook will attempt to cover a large number of topics, some of which apply only to embedded systems, but some of which will apply to nearly all computers (embedded or otherwise). As such, there is a chance that some of the material from this book will overlap with material from other wikibooks that are focused on topics such as low-level computing, assembly language, computer architecture, etc. But we will first start with the basics, and attempt to answer some questions before the book actually begins.

What is an Embedded Computer?

The first question that needs to be asked, is "What exactly is an embedded computer?" To be fair, however, it is much easier to answer the question of what an embedded computer is not, than to try and describe all the many things that an embedded computer can be. An embedded computer is frequently a computer that is implemented for a particular purpose. In contrast, an average PC computer usually serves a number of purposes: checking email, surfing the internet, listening to music, word processing, etc... However, embedded systems usually only have a single task, or a very small number of related tasks that they are programmed to perform.

Every home has several examples of embedded computers. Any appliance that has a digital clock, for instance, has a small embedded microcontroller that performs no other task than to display the clock. Modern cars have embedded computers onboard that control such things as ignition timing and anti-lock brakes using input from a number of different sensors.

Embedded computers rarely have a generic interface, however. Even if embedded systems have a keypad and an LCD display, they are rarely capable of using many different types of input or output. An example of an embedded system with I/O capability is a security alarm with an LCD status display, and a keypad for entering a password.

In general, an Embedded System:

- *Is a system built to perform its duty, completely or partially independent of human intervention.*
- *Is specially designed to perform a few tasks in the most efficient way.*
- *Interacts with physical elements in our environment, viz. controlling and driving a motor, sensing temperature, etc.*

An embedded system can be defined as a control system or computer system designed to perform a specific task. Common examples of embedded systems include MP3 players, navigation systems on aircraft and intruder alarm systems. An embedded system can also be defined as a single purpose computer.

Most embedded systems are time critical applications meaning that the embedded system is working in an environment where timing is very important: the results of an operation are only relevant if they take place in a specific time frame. An autopilot in an aircraft is a time critical embedded system. If the autopilot detects that the plane for some reason is going into a stall then it should take steps to correct this within milliseconds or there would be catastrophic results.

What are Embedded Systems Used For?

The uses of embedded systems are virtually limitless, because every day new products are introduced to the market that utilize embedded computers in novel ways. In recent years, hardware such as microprocessors, microcontrollers, and FPGA chips have become much cheaper. So when implementing a new form of control, it's wiser to just buy the generic chip and write your own custom software for it. Producing a custom-made chip to handle a particular task or set of tasks costs far more time and money. Many embedded computers even come with extensive libraries, so that "writing your own software" becomes a very trivial task indeed.

From an implementation viewpoint, there is a major difference between a computer and an embedded system. Embedded systems are often required to provide **Real-Time response**. A **Real-Time system** is defined as a system whose correctness depends on the timeliness of its response. Examples of such systems are flight control systems of an aircraft, sensor systems in nuclear reactors and power plants. For these systems, delay in response is a fatal error. A more relaxed version of **Real-Time Systems**, is the one where timely response with small delays is acceptable. Example of such a system would be the Scheduling Display System on the railway platforms. In technical terminology, **Real-Time Systems** can be classified as:

- **Hard Real-Time Systems** - systems with severe constraints on the timeliness of the response.
 - **Soft Real-Time Systems** - systems which tolerate small variations in response times.
 - **Hybrid Real-Time Systems** - systems which exhibit both hard and soft constraints on its performance.
-

What are Some Downfalls of Embedded Computers?

Embedded computers may be economical, but they are often prone to some very specific problems. A PC computer may ship with a glitch in the software, and once discovered, a software patch can often be shipped out to fix the problem. An embedded system, however, is frequently programmed once, and the software cannot be patched. Even if it is possible to patch faulty software on an embedded system, the process is frequently far too complicated for the user.

Another problem with embedded computers is that they are often installed in systems for which unreliability is not an option. For instance, the computer controlling the brakes in your car cannot be allowed to fail under any condition. The targeting computer in a missile is not allowed to fail and accidentally target friendly units. As such, many of the programming techniques used when throwing together production software cannot be used in embedded systems. Reliability must be guaranteed before the chip leaves the factory. This means that every embedded system needs to be tested and analyzed extensively.

An embedded system will have very few resources when compared to full blown computing systems like a desktop computer, the memory capacity and processing power in an embedded system is limited. It is more challenging to develop an embedded system when compared to developing an application for a desktop system as we are developing a program for a very constricted environment. Some embedded systems run a scaled down version of operating system called an RTOS (real time operating system).

Why Study Embedded Systems?

Embedded systems are playing important roles in our lives every day, even though they might not necessarily be visible. Some of the embedded systems we use every day control the menu system on television, the timer in a microwave oven, a cellphone, an MP3 player or any other device with some amount of intelligence built-in. In fact, recent poll data shows that embedded computer systems currently outnumber humans in the USA. Embedded systems is a rapidly growing industry where growth opportunities are numerous.

Who is This Book For?

This book is designed to accompany a course of study in computer engineering. However, this book will also be useful to any reader who is interested in computers, because this book can form the starting point for a "bottom up" learning initiative on computers. It is fundamentally easier to study small, limited, simple computers than it is to start studying the big PC behemoths that we use on a daily basis. Many topics covered in this book will be software topics as well, so this book will be the most helpful to people with at least some background in programming (especially C and Assembly languages). Having a prior knowledge of semiconductors and electric circuits will be beneficial, but will not be required.

What Will This Book Cover?

This book will focus primarily on embedded systems, but the reader needs to understand 2 simple facts:

1. This book cannot proceed far without a general discussion of microprocessor architecture
2. Many of the concepts discussed in this book apply equally well, if not better, to Desktop computers than to embedded computers.

In the general interests of completeness, this book will cover a number of topics that have general relevance to all computers in general. Many of the lessons in this book will even be better applied by a desktop computer programmer than by an embedded systems engineer. It might be more fair to say that this book is more about "Low Level Computing" than "Embedded Systems".

This book will, of course, cover many embedded systems topics that are irrelevant when programming desktop computers, such as cross-compilers, Real-Time Operating Systems, EEPROM storage, code compression, bit-banging serial ports, umbilical development, etc.

Where to Go From Here

After reading this book, there are a number of potential fields of study to continue learning.

- For people interested in operating systems, and hardware-software interfacing, read the Operating System Design wikibook.
- For people interested in C programming or Assembly Programming, see the Programming:C and X86 Assembly wikibooks, respectively.
- For people interested in digital control systems, there will eventually be a book on that topic here (Programmable Logic)
- For people interested in digital signal processing, there will eventually be a book on that subject.
- For people interested in a further study of more advanced computer systems, there will eventually be books on computer hardware and microprocessors here. (Microprocessor Design)
- For people interested in an even lower-level understanding of electronics, see Digital Circuits.
- Wikiversity: School of Very Small Information Systems is a course that includes using Java running on a FPGA.
- For people interested in designing motion control systems, that is, computer-controlled machines such as robots, machine tools, cars, buses, airplanes, ships, satellites, telescopes, etc., see Embedded Control Systems Design.

Which Programming Languages Will This Book Use?

We try to make this wikibook *language neutral*. It is not fair to focus on one language, when all embedded computers can't be programmed in that language.

However, it is nice to have functional example code in some real language. Also, it is useful to point out some features of popular programming languages that are especially important for embedded systems.

- ANSI C programming language: Many microprocessors and microcontrollers can be programmed in C, and a number of C cross-compilers exist for that purpose. C is perhaps the most frequently used language for new embedded system development. The "const" and the "volatile" keywords, rarely used in desktop app programming, become very important in Embedded Systems/C Programming.
- Assembly language: There are many different microcontroller families, each with their own assembly language with its own unique quirks. This book will cover some basics of assembly language common to most microcontrollers. Unlike desktop app programming, embedded system programs generally must set up an "interrupt vector table".
- This book will discuss (at least briefly) some techniques for multi-language programming (specifically C and assembly).
- There are some instances where microcontrollers are better programmed in a different language (BASIC and Forth come to mind)
- Some controllers are even programmed in their own proprietary languages (PIC Basic, and Dynamic C^[1] for instance).
- Some extremely well-known languages, such as C++ and Java, are rarely used in embedded systems, because C++ and Java compilers are simply unavailable for popular microcontrollers. However, this book may occasionally describe how to implement C++ and Java features in an environment that doesn't natively support them.
- Python compilers are available for some popular microcontrollers. Pyastra[2] compiles for all Microchip PIC12, PIC14 and PIC16 microcontrollers. PyMite[3] compiles for "any device in the AVR family that has at least 64 KiB program memory and 4 KiB RAM". PyMite also targets (some) ARM microcontrollers. Notice that these

embedded Python compilers typically can only compile a subset of the Python language for these devices.

Further reading:

- Robotics: Design Basics: Design software#Programming Languages
- Embedded Systems/PIC Programming#Compilers.2C_Assemblers

References

- [1] <http://imagnetools.com/support/downloads/>
- [2] <http://pyastra.sourceforge.net/>
- [3] <http://pymite.python-hosting.com/wiki/>

Embedded Systems/Terminology

This page will try to discuss some of the different, important terminology, and it may even contain a listing of some of the acronyms used in this book.

Types of Chips

There are a number of different types of chips that we will discuss here.

Microprocessors

These chips contain a processing core, and occasionally a few integrated peripherals. In a different sense, Microprocessors are simply CPUs found in desktops.

Microcontrollers

These chips are all-in-one computer chips. They contain a processing core, memory, and integrated peripherals. In a broader sense, a microcontroller is a CPU that is used in an embedded system.

Digital Signal Processor (DSP)

DSPs are the "best of the best" when it comes to microcontrollers. DSPs frequently run very quickly, and have immense processing power (for an embedded chip). Digital Signal Processors, and the field of Digital Signal Processing is so large and involved, that it warrants its own book -- Digital Signal Processing.

Grades of Microcontrollers

Microcontrollers can be divided up into different categories, depending on several parameters such as bus-width (8 bit, 16 bit, etc...), amount of memory, speed, and the number of I/O pins:

Low-end

Low-end chips are frequently used in simple situations, where speed and power are not a factor. Low-end chips are the cheapest of the bunch, and can usually cost *less than a dollar*, depending on the quantity in which they are purchased. Low-end chips rarely have many I/O pins (4 or 8, total), and rarely have any special capabilities. Almost all low-end chips are 8 bits or smaller.

Mid-level chips

mid-level chips are the "basic" microcontroller units. They don't suffer from the drawbacks of the low-end chips, but at the same time they are more expensive and larger. Mid-level chips are 8 bits or 16 bits wide, and frequently have a number of available I/O pins to play with. Mid-level chips may come with ADC, voltage regulators, OpAmps, etc... Mid-level chips can cost anywhere between \$1 and \$10 for reasonable chips.

High-end chips

High end chips are used in situations where power and speed are a must, but a conventional microprocessor board (think a computer motherboard) is too large or expensive. High-end chips will have a number of fancy features, more available memory, and a larger addressable memory range. High end chips can come in 8 bit, 16 bit, 32 bit or even 64 bit, and can cost anywhere between \$10 to \$100 each.

Acronyms

This will be a functional list of most of the acronyms used in this book

ADC

ADC stands for **Analog to Digital Converter**. ADCs are also written as "A/D" or "A2D" in other literature.

DAC

The exact opposite of an ADC, a DAC stands for **Digital to Analog Converter**. May also be called "D/A" or "D2A"

RAM

Random-Access Memory. RAM is the memory that a microcontroller uses to store information when the power is on. When the power goes off, RAM is erased.

ROM

Read-Only Memory, ROM is memory that can be read, but it cant be written or erased. ROM is cheaper than RAM, and it doesnt lose its information when the power is turned off.

OTP

OTP means **One-Time Programmable**. OTP chips can be programmed once, and only once, usually by a physical process or burning extra wires inside the chip. If an OTP chip is programmed incorrectly, it can't be fixed, so be careful with them.

downloading

In this book, the terms "burning", "flashing", "installing", or "downloading" all mean the same thing -- the automated process of putting the executable image into the non-volatile memory of the embedded system.

After a person tweaks the source code and compiles a new executable image on the PC, that person connects a downloader between the PC and the embedded system, and clicks the "go" button. Then the PC streams the image into the downloader, and the downloader burns the image into the embedded system.

A downloader is variously called a "downloader", "burner", "flasher", "flash downloader", "programming interface", or -- confusingly -- a "programmer".

- [Embedded_Systems/PIC_Microcontroller#downloaders](#)
- [Embedded_Systems/Atmel_AVR#Programming_Interfaces](#)

programming

Sometimes "programming" means the overall process of a person writing software on a PC, going through many edit-compile-download-burn-test cycles. Other times "programming" means the specific step of the "programmer" device burning the compiled code into the chip. Please help us make this book less confusing.

In this book, we use the term "programming" to describe what a human being does to create and test software source code.

Be aware that other texts may use the term "programming" -- such as when talking about "high-voltage programming", "gang programming", etc. -- to describe what we would call "installing". They may call the piece of hardware that does it a "programmer".

Texts that talk about "C++ programming", "assembly programming", "pair programming" etc. -- use "programming" the same way we do. "C++ programmer", "Python programmer", "pair programmer", etc. refer to human beings that do the programming.

for further reading

- We mentioned op amps. A long time ago, "analog computers" were once built entirely out of such operational amplifiers, resistors and capacitors. Today most embedded systems have few, if any op-amps -- they are still useful for some sensor signal amplifiers, anti-aliasing filters before the ADC, anti-aliasing filters after the DAC, and a few op-amps embedded in power supply circuits.

Microprocessor Basics

Embedded Systems/Microprocessor Introduction

Effectively programming an embedded system, and implementing it reliably requires the engineer to know many of the details of the system architecture. Section 1 of the Embedded Systems book will cover some of the basics of microprocessor architecture. This information might not apply to all embedded computers, and much of it may apply to computers in general. This book can only cover some basic concepts, because the actual embedded computers available on the market are changing every day, and it is the engineer's responsibility to find out what capabilities and limitations their particular systems have.

As people continue to pack more and more transistors onto a single chip, more and more of the stuff that was once "peripheral logic" has been integrated on the same chip as the CPU. A *microcontroller* includes most or all the electronics needed in an embedded system in a single integrated circuit ("chip").^[1]

- CPU
- I/O ports
- RAM - contains temporary data
- "ROM" - contains program and constant data -- the firmware. Starting in 1993, many microcontrollers use Flash memory instead of true ROM to hold the firmware, but many engineers still refer to the Flash memory that holds the firmware as "ROM" from force of habit.
- timers -- we discuss these later at Embedded Systems/Programmable Controllers#Timers.
- serial interface -- often a USART -- we discuss these later at Embedded Systems/Serial and Parallel IO
- EEPROM - contains "permanent" data
- analog-to-digital converter

This list is roughly in order of integration. The earliest microcontrollers contained only the CPU and I/O ports; modern microprocessors typically contain the CPU, some I/O ports, and a lot of cache RAM; the cost of a microcontroller dropped dramatically once the CPU, I/O, RAM, and ROM could all be squeezed onto the same chip, because such a microcontroller no longer needs "address pins"; etc. The most highly integrated microcontrollers include all these parts on one chip.

Should we say something about "Harvard architecture" here?

Further reading

Learn Electronics/Microprocessors

[1] "Microcontrollers made easy" (<http://www.st.com/stonline/books/pdf/docs/4966.pdf>) ST AN887

Embedded Systems/Embedded System Basics

Embedded systems programming is not like normal PC programming. In many ways, programming for an embedded system is like programming a PC 15 years ago. The hardware for the system is usually chosen to make the device as cheap as possible. Spending an extra dollar a unit in order to make things easier to program can cost millions. Hiring a programmer for an extra month is cheap in comparison. This means the programmer must make do with slow processors and low memory, while at the same time battling a need for efficiency not seen in most PC applications. Below is a list of issues specific to the embedded field.

Tools

Embedded development makes up a small fraction of total programming. There's also a large number of embedded architectures, unlike the PC world where 1 instruction set rules, and the Unix world where there's only 3 or 4 major ones. This means that the tools are more expensive. It also means that they're lower featured, and less developed. On a major embedded project, at some point you will almost always find a compiler bug of some sort.

Debugging tools are another issue. Since you can't always run general programs on your embedded processor, you can't always run a debugger on it. This makes fixing your program difficult. Special hardware such as JTAG ports can overcome this issue in part. However, if you stop on a breakpoint when your system is controlling real world hardware (such as a motor), permanent equipment damage can occur. As a result, people doing embedded programming quickly become masters at using serial IO channels and error message style debugging.

Resources

To save costs, embedded systems frequently have the cheapest processors that can do the job. This means your programs need to be written as efficiently as possible. When dealing with large data sets, issues like memory cache misses that never matter in PC programming can hurt you. Luckily, this won't happen too often- use reasonably efficient algorithms to start, and optimize only when necessary. Of course, normal profilers won't work well, due to the same reason debuggers don't work well. So more intuition and an understanding of your software and hardware architecture is necessary to optimize effectively.

Memory is also an issue. For the same cost savings reasons, embedded systems usually have the least memory they can get away with. That means their algorithms must be memory efficient (unlike in PC programs, you will frequently sacrifice processor time for memory, rather than the reverse). It also means you can't afford to leak memory ^[1]. Embedded applications generally use deterministic memory techniques and avoid the default "*new*" and "*malloc*" functions, so that leaks can be found and eliminated more easily.

Other resources programmers expect may not even exist. For example, most embedded processors do not have hardware FPUs ^[2] (Floating-Point Processing Unit). These resources either need to be emulated in software, or avoided altogether.

Real Time Issues

Embedded systems frequently control hardware, and must be able to respond to them in real time. Failure to do so could cause inaccuracy in measurements, or even damage hardware such as motors. This is made even more difficult by the lack of resources available. Almost all embedded systems need to be able to prioritize some tasks over others, and to be able to put off/skip low priority tasks such as UI in favor of high priority tasks like hardware control.

Fixed-Point Arithmetic

Some embedded microprocessors may have an external unit for performing floating point arithmetic(FPU), but most low-end embedded systems have no FPU. Most C compilers will provide software floating point support, but this is significantly slower than a hardware FPU. As a result, many embedded projects enforce a no floating point rule on their programmers. This is in strong contrast to PCs, where the FPU has been integrated into all the major microprocessors, and programmers take fast floating point number calculations for granted. Many DSPs also do not have an FPU and require fixed-point arithmetic to obtain acceptable performance.

A common technique used to avoid the need for floating point numbers is to change the magnitude of data stored in your variables so you can utilize fixed point mathematics. For example, if you are adding inches and only need to be accurate to the hundredth of an inch, you could store the data as hundredths rather than inches. This allows you to use normal fixed point arithmetic. This technique works so long as you know the magnitude of data you are adding ahead of time, and know the accuracy to which you need to store your data.

We will go into more detail on fixed-point and floating-point numbers in a later chapter.

further reading

- Floating Point/Fixed-Point Numbers

References

[1] http://en.wikipedia.org/wiki/Memory_leak

[2] http://en.wikipedia.org/wiki/Floating_point_unit

Embedded Systems/Microprocessor Architectures

The chapters in this section will discuss some of the basics in microprocessor architecture. They will discuss how many features of a microprocessor are implemented, and will attempt to point out some of the pitfalls (speed decreases and bottlenecks, specifically) that each feature represents to the system.

Memory Bus

In a computer, a processor is connected to the RAM by a data bus. The data bus is a series of wires running in parallel to each other that can send data to the memory, and read data back from the memory. In addition, the processor must send the address of the memory to be accessed to the RAM module, so that the correct information can be manipulated.

Multiplexed Address/Data Bus

In old microprocessors, and in some low-end versions today, the memory bus is a single bus that will carry both the address of the data to be accessed, and then will carry the value of the data. Putting both signals on the same bus, at different times is a technique known as "time division multiplexing", or just **multiplexing** for short. The effect of a multiplexed memory bus is that reading or writing to memory actually takes twice as long: half the time to send the address to the RAM module, and half the time to access the data at that address. This means that on a multiplexed bus, moving data to and from the memory is a very expensive (in terms of time) process, and therefore memory read/write operations should be minimized. It also makes it important to ensure algorithms which work on large datasets are cache efficient.

Demultiplexed Bus

The opposite of a multiplexed bus is a **demultiplexed bus**. A demultiplexed bus has the address on one set of wires, and the data on another set. This scheme is twice as fast as a multiplexed system, and therefore memory read/write operations can occur much faster.

Bus Speed

In modern high speed microprocessors, the internal CPU clock may move much faster than the clock that synchronizes the rest of the microprocessor system. This means that operations that need to access resources outside the processor (the RAM for instance) are restricted to the speed of the bus, and cannot go as fast as possible. In these situations, microprocessors have 2 options: They can wait for the memory access to complete (slow), or they can perform other tasks while they are waiting for the memory access to complete (faster). Old microprocessors and low-end microprocessors will always take the first option (so again, limit the number of memory access operations), while newer, and high-end microprocessors will often take the second option.

I/O Bus

Any computer, be it a large PC or a small embedded computer, is useless if it has no means to interact with the outside world. I/O communications for an embedded computer frequently happen over a bus called the **I/O Bus**. Like the memory bus, the I/O bus frequently multiplexes the input and output signals over the same bus. Also, the I/O bus is moving at a slower speed than the processor is, so large numbers of I/O operations can cause a severe performance bottleneck.

It is not uncommon for different IO methods to have separate buses. Unfortunately, it is also not uncommon for the electrical engineers designing the hardware to cheat and use a bus for more than 1 purpose. Doing so can save the need for extra transistors in the layout, and save cost. For example, a project may use the USB bus to talk to some LEDs that are physically close by. These different devices may have very different speeds of communication. When programming IO bus control, make sure to take this into account.

In some systems, memory mapped IO is used. In this scheme, the hardware reads its IO from predefined memory addresses instead of over a special bus. This means you'll have simpler software, but it also means main memory will get more access requests.

Programming the IO Bus

When programming IO bus controls, there are 5 major variations on how to handle it- the main thread poll, the multithread poll, the interrupt method, the interrupt+thread method, and using a DMA controller.

Main thread poll

In this method, whenever you have output ready to be sent, you check if the bus is free and send it. Depending on how the bus works, sending it can take a large amount of time, during which you may not be able to do anything else. Input works similarly- every so often you check the bus to see if input exists.

Pros:

- Simple to understand

Cons:

- Very inefficient, especially if you need to push the data manually over the bus (instead of via DMA)
- If you need to push data manually, you are not doing anything else, which may lead to problem with real time hardware
- Depending on polling frequency and input frequency, you could lose data by not handling it fast enough

In general, this system should only be used if IO only occurs at infrequent intervals, or if you can put it off when there are more important things to do. If your system supports multithreading or interrupts, you should use other techniques instead.

Multithread polling

In this method, we spawn off a special thread to poll. If there is no IO when it polls, it puts itself back to sleep for a predefined amount of time. If there is IO, it deals with it on the IO thread, allowing the main thread to do whatever is needed.

Pros:

- Does not put off the main thread
- Allows you to define the importance of IO by changing the priority of the thread

Cons:

- Still somewhat inefficient
- If IO occurs frequently, your polling interval may be too small for you to sleep sufficiently, starving other threads
- If your thread is too low in priority or there are too many threads for the OS to wake the thread in a timely fashion, data can be lost.
- Requires an OS capable of threading

This technique is good if your system supports threading, but does not support interrupts or has run out of interrupts. It does not work well when frequent IO is expected- the OS may not properly sleep the thread if the interval is too small, and you will be adding the overhead of 2 context switches per poll.

Interrupt architecture

(The interrupt architecture uses interrupts, which we discuss in more detail in chapter Embedded Systems/Interrupts).

In this method, the bus fires off an interrupt to the processor whenever IO is ready. The processor then jumps to a special function, dropping whatever else it was doing. The special function (called an interrupt handler, or interrupt service routine) takes care of all IO, then goes back to whatever it was doing.

Pros:

- Very efficient
- Very simple, requires only 1 function

Cons:

- If dealing with IO takes a long time, you can starve other things. This is especially dangerous if your handler masks interrupts, which can cause you to miss hardware interrupts from real time hardware
- If your handler takes so long more input is ready before you handle existing input, data can be lost.

This technique is great so long as dealing with the IO is a short process, such as when you just need to set up DMA. If its a long process, use multithreaded polling or interrupts with threads.

Interrupts and threads

We discuss this technique in more detail in Embedded Systems/Interrupts

In this technique, you use an interrupt to detect when IO is ready. Instead of dealing with the IO directly, the interrupt signals a thread that IO is ready and lets that thread deal with it. Signalling the thread is usually done via semaphore- the semaphore is initialized to the taken state. The IO thread tries to take the semaphore, which fails and the OS puts it to sleep. When IO is ready, the interrupt is fired and releases the semaphore. The thread then wakes up, and handles the IO before trying to take the semaphore and being put back to sleep.

The routine the interrupt vector points at is the "first level interrupt handler". The thread that the OS later wakes up to handle the rest of the work is the "second level interrupt handler".

Pros:

- minimum latency -- instead of all other interrupts being disabled until that interrupt is completely handled, interrupts are turned back on (at the end of the first level interrupt handler) as soon as possible.
- Does not put off the main thread
- Allows you to define the importance of IO by changing the priority of the thread
- Very efficient- only makes context changes when needed and does not poll.
- Very clean solution architecturally, allows you to be very flexible in how you handle IO.
- The second level interrupt handler can wait for a lock to be released (Embedded Systems/Locks and Critical Sections).

Cons:

- Requires an OS capable of threading
- Most complex solution

This solution is the most flexible, and one of the most efficient. It also minimizes the risk of starving more important tasks. Its probably the most common method used today.

DMA (Direct Memory Access) Controller

In some specialised situations, such as where a set of data must be transferred to a communications IO device, a DMA controller may be present that can automatically detect when the IO device is ready for more data, and transfer that data. This technique may be used in conjunction with many of the other techniques, for instance an interrupt may be used when the data transfer is complete.

Pros:

- This provides the best performance, since the I/O can happen in parallel with other code execution

Cons:

- Only applicable to a limited range of problems
- Not all systems have DMA controllers. This is especially true of the more basic 8-bit microcontrollers.
- Parallel nature may complicate a system

Embedded Systems/Programmable Controllers

The original 8086 processor shipped with a number of peripheral chips that each performed different tasks. Among these chips were programmable Interrupt controllers, programmable timers, and programmable I/O chips that could handle many of the tasks of the original computer, to take some of the computational strain off the 8086. In new versions of Intel chips (486, Pentium, etc) many of the peripheral chips have been integrated into the processor, in an attempt to speed up the entire computer. However, much of the functionality remains, even in today's high-end computer systems.

Timers

Timers are incredibly useful for performing a number of different operations. For instance, many multi-threaded operating systems operate by setting a timer, and then switching to a different thread every time the timer is triggered. Programmable timer chips can often be programmed to provide a variety of different timing functions, to take the burden off the microprocessor.

Another common application of a timer is to keep track of the time in human units of hours and minutes, and often years, months, and days. Often this real-time clock (RTC) has a battery to keep it running even in systems that are usually plugged into line power. Such a timer can save power in two ways:

- When we want to know what time it is -- for example, when a digital camera time-stamps a picture it just took -- the system can read it from the real-time clock. Other ways of figuring out the time require more energy.
- When a system needs to do something periodically -- for example, measure the outside temperature every 10 seconds, and transmit it wirelessly to an indoor display -- the system can turn off power to everything except the real-time clock, and then wait for the clock to wake it up.

You can see some of the 8086 compatible timer chips like 8253/54 also they are the same have three independent timers internally but 8254 can work with higher frequencies and is used to generate interrupt like Memory refresh interrupt ,Time of day TOD interrupt and the last one is used to generate the speaker frequencies.

Practically all microcontrollers sold today include integrated timer "peripherals" on the same chip. Most embedded systems either (a) have no external timer chip at all, using only the internal timers, (b) an external real-time clock, or (c) attempt to be PC compatible with a "southbridge" chip that emulates both the 8253-compatible timers and the real-time clock.

Interrupt Controllers

The original 8086 processor had only a single pin used for signaling an interrupt, so a programmable interrupt controller would handle most of the messy details of calling the interrupt. Also, a programmable interrupt controller could be used to monitor an input port for instance, and triggering an interrupt routine when input is received.

Direct Memory Access

Since memory read/write operations take longer than other operations for the microprocessor, one should avoid moving large blocks of memory. Luckily, the original 8086 came with a programmable direct memory access controller (DMA) for use in automatically copying and moving segments of memory. DMAs could also be used for implementing memory-mapped I/O, by being programmed to automatically move memory data to and from an output port.

DMA memory copies can also greatly enhance system performance by allowing the CPU to execute code in parallel with a DMA controller automatically performing the memory copy.

Peripheral Interface Controllers

Peripheral interface controllers take a number of different forms. Each different type of port has a different controller that the microprocessor will interface with to send the output on that port. For instance there are controllers for parallel ports and more modern USB ports. These controllers are used for controlling settings on output such as timing, and setting different modes on the output/input port.

Further reading

- x86 Assembly/Programmable Interrupt Timer

Embedded Systems/Floating Point Unit

Floating point numbers are

Like all information, floating point numbers are represented by bits.

Early computers used a variety of floating-point number formats. Each one required slightly different subroutines to add, subtract, and do other operations on them.

Because some computer applications use floating point numbers a lot, Intel standardized on one particular format, and designed floating-point hardware that calculated much more quickly than the software subroutines. The 80186 shipped with a floating-point co-processor dubbed the 80187. The 80187 was a floating point math unit that handled the floating point arithmetic functions. In newer processors, the floating point unit (FPU) has been integrated directly into the microprocessor.

Many small embedded systems, however, do not have an FPU (internal or external). Therefore, they manipulate floating-point numbers, when necessary, the old way. They use software subroutines, often called a "floating point emulation library".

However, floating-point numbers are not necessary in many embedded systems. Many embedded system programmers try to eliminate floating point numbers from their programs, instead using fixed-point arithmetic. Such programs use less space (fixed-point subroutine libraries are far smaller than floating-point libraries, especially when just one or two routines are put into the system). On microprocessors without a floating-point unit, the fixed-point version of a program usually runs faster than floating-point version. However, these embedded system programmers must figure out exactly how much accuracy a particular application needs, and make sure their fixed-point routines maintain at least that much accuracy.

math routines

(Is there a better place in this wikibook for this discussion? It doesn't even mention floating point.)

Low-end embedded microcontrollers typically don't even have integer multiply in their instruction set[1].

So on low-end CPUs, you must use routines that synthesize basic math operators (multiply, divide, square root, etc.) from even simpler steps. Practically all microprocessors have such routines, posted on the internet by their manufacturer or other users ("Multiplication and Division Made Easy" [2] by Robert Ashby, "Novel Methods of Integer Multiplication and Division" [3], "efficient bit twiddling methods" [4], etc.).

Following the advice known as "Make It Work Make It Right Make It Fast" [5] and "Make It Work Make It Small Make It Fast" [6], many people pick one or two number resolutions that are adequate for the largest kind of data handled in a program, and used that resolution for everything. For desktop machines, often 32-bit integers and 64 bit "double precision floating point" numbers are more than adequate. For embedded systems, often 24-bit integers and 24-bit "fixed point" numbers are more than adequate. If the software fits in the microcontroller, and is plenty fast enough, it is a waste of valuable human time to try to "optimize" it further.

Alas, sometimes the software does not fit in the microcontroller.

- If you run out of RAM, sometimes you only need 2 bytes or 1 byte or 4 bits or 1 bit to store a particular variable.
 - If you run out of time, sometimes you can add lower-precision math routines that quickly calculate the results needed for that inner loop, even though other parts of the code may need higher-precision math routines.
 - If you run out of ROM, sometimes you can trade time for ROM space. Rather than a collection of sets of math routines, each one customized to a slightly different width, you can use a single set of math routines that can handle the maximum possible width. If you have some variables less than that width (to save RAM), then you typically sign-extend variables into a full-size register or global buffer, do full-width calculations there, and then truncate and store the result to the small size.
-

FFT

Many people do FFT using fixed-point arithmetic.

... more tips and hints here ...

- "Develop FFT apps on low-power MCUs" ^[7] by Paul Holden 2005
- "Comparing Floating-Point and Fixed-Point Implementations on ADI Blackfin Processors with LabVIEW" ^[8]
- "Fixed-Point Fast Fourier Transform (FFT)" ^[9]
- (program listed for a fixed-point FFT) ^[10]
- EE-18: Choosing and Using FFTs for ADSP-21xx ^[11] (a fixed-point DSP)

Further reading

- Floating Point/Fixed-Point Numbers
- Floating Point/Fixed-Point Numbers
- AN660: floating point routines for the Microchip PICmicro ^[12]
- AN617: fixed point routines for the Microchip PICmicro ^[13]
- "Algorithm - ArcTan as Fast as You Can - AN2341" ^[14] fixed point routine for the Cypress PSoC
- "Floating Point Approximations" ^[15] collected by the Ganssle Group, giving code and test cases. (Assumes you already have floating-point add, subtract, multiply, and divide, and gives formulas for trig, roots, logarithms, and exponents ... various formulas, with different tradeoffs between accuracy, speed, and range).

References

- [1] <http://archive.chipcenter.com/eexpert/rashby/rashby059.html>
- [2] <http://archive.chipcenter.com/eexpert/rashby/rashby002.html>
- [3] <http://massmind.org/techref/method/math/muldiv.htm>
- [4] <http://massmind.org/techref/method/bits.htm>
- [5] <http://c2.com/cgi/wiki?MakeItWorkMakeItRightMakeItFast>
- [6] <http://c2.com/cgi/wiki?MakeItWorkMakeItSmallMakeItFast>
- [7] http://www.embedded.com/columns/technicalinsights/172302493?_requestid=742859
- [8] <http://zone.ni.com/devzone/cda/tut/p/id/3115>
- [9] http://www.mathworks.com/products/demos/shipping/fixedpoint/fi_radix2fft_demo.html?product=PO
- [10] <http://www.ceet.niu.edu/faculty/kuo/exp/exp7.html>
- [11] http://www.analog.com/UploadedFiles/Application_Notes/275080109ee_18.pdf
- [12] http://www.microchip.com/stellent/idcplg?IdcService=SS_GET_PAGE&nodeId=1824&appnote=en010982
- [13] http://www.microchip.com/stellent/idcplg?IdcService=SS_GET_PAGE&nodeId=1824&appnote=en010962
- [14] <http://www.cypress.com/design/AN2341>
- [15] <http://www.ganssle.com/approx.htm>

Embedded Systems/Parity

In many instances, especially in transmission, it is important to include some amount of error-checking information, so that incorrect information can be determined and discarded. One of the most simple method of error-checking is called **parity**. Parity can be broken up into Even Parity, and Odd Parity schemes. A parity check consists of a single bit that is set, depending on a certain condition.

Even Parity

In an even parity scheme, the parity bit is set if an odd number of bits in the data are set to 1 (to make the total number of 1 bits even). For instance, 01001100 would generate an even parity bit, while 11001100 would not generate one.

Odd Parity

The opposite of Even parity, odd parity generates a parity bit if there are an even number of high-bits in the data (to create an odd number of 1's).

Limitations of Parity

Simple 1-bit parity is only able to detect a single bit error, or an error in an odd number of bits. If an even number of bits (2, 4, 6, 8) are transmitted in error, the parity check will not catch the mistake

However, chances of getting 2 errors in 1 transmission is much much smaller than getting only 1 error in 1 transmission. so parity checks serve as a cheap and easy way to check for errors.

More advanced error detection

ECC codes are often used for the same reasons as parity bits. These codes use more bits, however they allow multi bit error detection, and also correction of single bit errors.

CRC checks are usually used at the end of data blocks. These are carefully designed to give a very high probability of detecting corruption of the data block, no matter how many bit errors are in the block.

Embedded Systems/Memory

On an Embedded System, memory is at a premium. Some chips, particularly embedded VLSI chips, and low-end microprocessors may only have a small amount of RAM "on board" (built directly into the chip), and therefore their memory is not expandable. Other embedded systems have a certain amount of memory, and have no means to expand. In addition to RAM, some embedded systems have some non-volatile memory, in the form of miniature magnetic disks, FLASH memory expansions, or even various 3rd-party memory card expansions. Keep in mind however, that a memory upgrade on an embedded system may cost more than the entire system itself. An embedded systems programmer, therefore, needs to be very much aware of the memory available, and the memory needed to complete a task.

Memory is frequently broken up into a number of different regions that are set aside for particular purposes.

addressable areas

There are typically 4 distinct addressable areas, each one implemented with a different technology:

- program memory (which holds the programs you write), often called ROM (although most developers prefer to use chips that actually implement this with Flash). While your program is running, it is impossible to change any of the data in program memory. But at least when the power comes back on, it's all still there.
- RAM, which holds the variables and stack. (Initial values for variables are copied from ROM). Forgets everything when power is lost.
- EEPROM. Used kind of like the hard drive in a personal computer, to store settings that might change occasionally, and that need to be remembered next time it starts up.
- I/O. This is really the entire point of a microcontroller.

Many popular microcontrollers (including the 8051, the Atmel AVR, the Microchip PIC, the Cypress PSoC) have a "Harvard architecture", meaning that programs can only execute out of "ROM". You can copy bytes from ROM (or elsewhere) into RAM, but it's physically impossible to jump or call such "code" in RAM. This is exactly the opposite of the situation on desktop computers, where the code you write cannot be executed until after it is copied into RAM.

A few popular microcontrollers (such as the 68HC11 and 68HC12 and ...) have a unified address space (a "von Neumann architecture"). You can jump or call code anywhere (although jumping to an address in I/O space is almost certainly not what you really wanted to do).

paging and banking

Often software applications grow and grow. Ancient processors (such as the 8085 used on the Mars rover Sojourner) with 16 bit address registers can directly access a maximum of 65 536 locations -- however, systems using these processors often have much more physical RAM and ROM than that. They use "paging" hardware that swaps in and out "banks" of memory into the directly accessible space. Early Microchip PIC processors had 2 completely separate set of "banking registers", one for swapping in different banks of program ROM, the other for swapping in different banks of RAM.

memory management

All too often, programs written for embedded systems grow and grow until they exceed the available program space. There are a variety of techniques^[1] for dealing with the out-of-memory problem:

- re-compile with the "-Os" (optimize for size) option
- find and comment-out "dead code"
- "refactor" repeated sections into a common subroutine
- trade RAM space for program space.
- put a small interpreter in "internal program memory" that loads and interprets "instructions".
 - use "instructions" -- perhaps p-code or threaded code -- that are more compact than directly coding it in assembly language. Or
 - place these "instructions" can be placed in EEPROM or external serial Flash that couldn't otherwise be used as program memory. Or
 - Both. This technique is often used in "stamp" style CPU modules.
- add more memory (perhaps using a paging or banking scheme)

Most CPUs used in desktop machines have a "memory management unit" (MMU). The MMU handles virtual memory, protects regions of memory used by the OS from untrusted programs, and ...

Most embedded systems do not have a MMU. We discuss the two versions of Linux that can run on a system that does not have a MMU in Embedded Systems/Linux.

x86 Memory Layout

Reserved Memory

Reserved memory is memory which is reserved for some purpose like additional software installation and startup."

Segmented Memory

Old x86 processors were only 16 bit processors, and if a flat memory scheme was used, those processors would only be able to support 65 Kilobytes of memory. The system engineers behind the old 8086 and 80286 processors came up with the idea to segment memory, and use a combination of segment pointers and offset pointers to access an effective 20 bit address range, for a maximum of 1 megabyte of addressable memory.

Address = (Segment register * 16) + pointer register

New 32 bit processors allow for 4 Gigabytes of addressable memory space, and therefore the segmented memory model was all but abandoned in current 32 bit machines (although the segment registers are still used to implement paging schemes).

Memory-Mapped I/O

Memory-Mapped I/O is a mechanism by which the processor performs I/O access by using memory access techniques. This is often put into effect because the memory bus is frequently much faster than the I/O bus. Another reason that memory mapped I/O might be used is that the architecture in use does not have a separate I/O bus.

In memory mapped IO, certain range of CPU's address space is kept aside for the external peripherals. These locations can be accessed using the same instructions as used for other memory accesses. But instead, the read/writes to these addresses are interpreted as access to device rather than a location on the main memory.

A CPU may expect a particular device at a fixed location or can dynamically assign a space for it.

The way this works is that memory interfaces are often designed as a bus (a shared communications resource), where many devices are attached. These devices are usually arranged as master and slave devices, where a master device

can send and receive data from any of the slave devices. A typical system would have:

- A CPU as the master
- One or more RAM and/or ROM devices for program code and data storage
- Peripheral devices for interfacing with the outside world. Examples of these might be a UART (serial communications), Display device or Input device

Further reading

Some popular interpreters for small systems (some of which we briefly mentioned before) include:

- Forth; one Forth wiki ^[2] lists many ports of Forth to many embedded systems.
- (a subset of) Python
- (a subset of) BASIC Programming, typically a tokenized BASIC such as PBASIC or PICAXE BASIC
- Wikipedia: CHIP-8
- Wikipedia: XPL0
- (a subset of) Lua Functional Programming ([3])
- (a subset of) Objective Caml ([4])
- (a subset of) Embedded Systems/C Programming, a C interpreter such as PicoC ^[5] or Wikipedia: Interactive C.
- "What are the available interactive languages that run in tiny memory?" at Stack Overflow ^[6]

References

[1] Data Compression#executable software compression

[2] <http://wiki.forthfreak.net/>

[3] <http://sourceforge.net/projects/hplua>

[4] <http://www.calcwatch.com/forum/viewtopic.php?pid=789#p789>

[5] <http://code.google.com/p/picoc/>

[6] <http://stackoverflow.com/questions/1082751/what-are-the-available-interactive-languages-that-run-in-tiny-memory>

Embedded Systems/Memory Units

ROM

One type of memory that is as cheap as it is useless is Read-Only Memory (ROM). I say that it is useless because you can program it once, and then you can never change the data that is on it. This makes it useless because you can't upgrade the information on the ROM chip (be it program code or data), you can't fix it if there is an error, etc.... Because of this, they are usually called "Programmable Read-Only Memory" (PROM), because you can program it once, but then you can't change it at all.

EPROM

In contrast to PROM is EPROM ("Erasable Programmable Read-Only Memory"). EPROM chips will have a little window, made of either glass or quartz that can be used to erase the memory on the chip. To erase an EPROM, the window needs to be uncovered (they usually have some sort of guard or cover), and the EPROM needs to be exposed to UV radiation to erase the memory, and allow it to be reprogrammed.

EEPROM

A step up from EPROM is EEPROM ("Electrically Erasable Programmable Read-Only Memory"). EEPROM can be erased by exposing it to an electrical charge. This means that EEPROM can be erased in circuit (as opposed to EPROM, which needs to be removed from the circuit, and exposed to UV). An appropriate electrical charge will erase the entire chip, so you can't erase just certain data items at a time.

Many modern microcontroller have an EEPROM section on-board, which can be used to permanently store system parameters or calibration values. These are often referred to as non-volatile memory (NVM). They can be accessed - read and write - as single bytes or blocks of bytes. Like Flash memory EEPROM allows only a limited number of write cycles, usually several ten-thousand.

Write access to on-board NVM tends to be considerably slower than RAM. Embedded software must take this into account and "queue" write requests to be executed in background.

RAM

Random Access Memory (RAM) is a temporary, volatile memory that requires a persistent electric current to maintain information. As such, a RAM chip will not store data when you turn the power OFF. RAM is more expensive than ROM, and it is often at a premium: Embedded systems can have many Kbytes of ROM (sometimes Megabytes or more), but often they have less than 100 **bytes** of RAM available for use in program flow.

FLASH Memory

Flash memory is a combination of the best parts of RAM and ROM. Like ROM, Flash memory can hold data when the power is turned off. Like RAM, Flash can be reprogrammed electrically, in whole or in part, at any time during program execution.

Flash memory modules are only good for a limited number of Read/Write cycles, which means that they can burn out if you use them too much, too often. As such, Flash memory is better used to store persistent data, and RAM should be used to store volatile data items.

Programming Embedded Systems

Embedded Systems/C Programming

The C programming language is perhaps the most popular programming language for programming embedded systems. (Earlier Embedded Systems/Embedded Systems Introduction#Which Programming Languages Will This Book Use? we mentioned other popular programming languages).

Most C programmers are spoiled because they program in environments where not only is there a standard library implementation, but there are frequently a number of other libraries available for use. The cold fact is, that in embedded systems, there rarely are many of the libraries that programmers have grown used to, but occasionally an embedded system might not have a complete standard library, if there is a standard library at all. Few embedded systems have capability for dynamic linking, so if standard library functions are to be available at all, they often need to be directly linked into the executable. Often times, because of space concerns, it is not possible to link in an entire library file, and programmers are often forced to "brew their own" standard c library implementations if they want to use them at all. While some libraries are bulky and not well suited for use on microcontrollers, many development systems still include the standard libraries which are the most common for C programmers.

C remains a very popular language for micro-controller developers due to the code efficiency and reduced overhead and development time. C offers low-level control and is considered more readable than assembly. Many free C compilers are available for a wide variety of development platforms. The compilers are part of an IDEs with ICD support, breakpoints, single-stepping and an assembly window. The performance of C compilers has improved considerably in recent years, and they are claimed to be more or less as good as assembly, depending on who you ask. Most tools now offer options for customizing the compiler optimization. Additionally, using C increases portability, since C code can be compiled for different types of processors.

Example

An example of using C to change a bit is below

Clearing Bits

```
PORTH &= 0xF5; // Changes bits 1 and 3 to zeros using C
PORTH &= ~0x0A; // Same as above but using inverting the bit mask - easier to see which bits are cleared
```

Setting Bits

```
PORTH |= 0x0A; // Set bits 1 and 3 to one using the OR
```

In assembly this would be

Clearing Bits

```
BCLR PORTH,$0A ;Changes bits 1 and 3 to zeros using 68HC12 ASM
```

Setting Bits

```
BSET PORTH,$0A ;Changes bits 1 and 3 to ones using 68HC12 ASM
```

Special Features

The C language is standardized, and there are a certain number of operators available that everybody knows and loves. However, many microprocessors have capabilities that are either beyond what C can do, or are faster than the way C does it. For instance, the 8051 and PIC microcontrollers both have assembly instructions for setting and checking individual bits in a byte. C can affect bits individually using clunky structures known as "bit fields", but bit field implementations are rarely as fast as the bit-at-a-time operations on some microprocessors.

Bit Fields

Bit fields are a topic that few C programmers have any experience with, although it has been a standardized part of the language for some time now. Bit fields allow the programmer to access memory in unaligned sections, or even in sections *smaller than a byte*. Let us create an example:

```
struct _bitfield {
    flagA : 1;
    flagB : 1;
    nybbA : 4;
    byteA : 8;
}
```

The colon separates the name of the field from its size *in bits, not bytes*. Suddenly it becomes very important to know what numbers can fit inside fields of what length. For instance, the flagA and flagB fields are both 1 bit, so they can only hold boolean values (1 or 0). the nybbA field can hold 4 bits, for a maximum value of 15 (one hexadecimal digit).

fields in a bitfield can be addressed exactly like regular structures. For instance, the following statements are all valid:

```
struct _bitfield field;
field.flagA = 1;
field.flagB = 0;
field.nybbA = 0x0A;
field.byteA = 255;
```

The individual fields in a bit field do not take storage types, because you are manually defining how many bits each field takes. *I wish that's how Richie had done it. However, I'm pretty sure that: Each bit field requires a storage type such as "unsigned". See "Declaring and Using Bit Fields in Structures"^[1]; "Allowable bit-field types"^[2].*

However, the fields in a bitfield may be qualified with the keywords "signed" or "unsigned", although "signed" is implied, if neither is specified.

If a 1-bit field is marked as signed, it has values of +1 and 0. *Allow me to quote from Wiki:BitField: A signed 1-bit bit-field that can contain 1 is a bug in the compiler.*

It is important to note that different compilers may order the fields differently in a bitfield, so the programmer should never attempt to access the bitfield as an integer object. Without trial and error testing on your individual compiler, it is impossible to know what order the fields in your bitfield will be in.

Also bitfields are aligned, like any other data object on a given machine, to a certain boundary.

const

A "const" in a variable declaration is a promise by the programmer who wrote it that the program will not alter the variable's value.

There are 2 slightly different reasons "const" is used in embedded systems.

One reason is the same as in desktop applications:

Often a structure, array, or string is passed to a function using a pointer. When that argument is described as "const", such as when a header file says

```
void print_string( char const * the_string );
```

, it is a promise by the programmer who wrote that function that the function will not modify any items in the structure, array, or string. (If that header file is properly #included in the file that implements that function, then the compiler will check that promise when that implementation is compiled, and give an error if that promise is violated).

On a desktop application, such a program would compile to exactly the same executable if all the "const" declarations were deleted from the source code -- but then the compiler would not check the promises.

When some other programmer has an important piece of data he wants to pass to that function, he can be sure simply by reading the header file that that function will not modify those items. Without that "const", he would either have to go through the source code of the function implementation to make sure his data isn't modified (and worry about the possibility that the next update to that implementation might modify that data), or else make a temporary copy of the data to pass to that function, keeping the original version unmodified.

storing data in ROM

Another reason to use "const" is specific to embedded systems:

On many embedded systems, there is much more program Flash (or ROM) than RAM. A ".c" file that uses a definition such as

```
char * months[] = {
    "January", "February", "March",
    "April", "May", "June",
    "July", "August", "September",
    "October", "November", "December",
};
```

forces the compiler to store all those strings in program Flash, then on boot-up, to copy those values to a location in RAM. That wastes precious RAM if, as is often the case, the program never actually modifies those strings. By modifying the declaration to

```
char const * const months[] = { ... };
```

, we inform the compiler that we promise to never modify those strings (or their order in the array), and so the compiler is free to store all those strings in program Flash, and fetch the original value from Flash whenever it is needed. That saves RAM for variables that really do change.

(Some compilers, if you use definitions such as

```
static char * months[] = { ... };
```

, are smart enough to work out for themselves whether or not that the program ever actually modifies those strings. If the program does modify those strings, then of course the compiler must put them in RAM. But if not, the compiler

is free to store those strings only once, in program Flash).

storing data in ROM on a Princeton architecture microcontrollers

Princeton architecture microcontrollers use exactly the same instructions to access RAM as program Flash.

C compilers for such architectures typically put all data declared as "const" into program Flash. Functions neither know nor care whether they are dealing with data from RAM or program Flash; the same "read" instructions work correctly whether the function is given a pointer to RAM or a pointer to program Flash.

storing data in ROM on a Harvard architecture microcontrollers

Unfortunately, Harvard architecture microcontrollers use completely different instructions to access RAM than program Flash. (Often they also have yet another set of instructions to access EEPROM, and another to access external memory chips). This makes it difficult to write a subroutine (such as puts()) that can be called from one part of the program to print out a constant string (such as "November") from ROM, and called from another part of the program to print out a variable string in RAM.

Unfortunately, different C compilers (even for the same chip) require different, incompatible techniques for a C programmer to tell a C compiler to put data in ROM. There are at least 3 ways for a C programmer to tell a C compiler to put data in ROM.

(1) Some people claim that using the "const" modifier to indicate that some data is intended to be stored in ROM is an abuse of notation. ^[3] Such people typically propose using some non-standard attribute or storage specifier, such as "PROGMEM" or "rom"^[4], on variable definitions and function parameters, to indicate "value resides in program Flash, not RAM". Unfortunately, different compilers have different, incompatible ways of specifying that data may be placed in ROM. Typically such people use function libraries that 2 copies of functions that deal with strings (etc.); one copy is used for strings in RAM, the other copy is used for strings in ROM. This technique uses the minimum amount of RAM, but it usually requires more ROM than other techniques.

(2) Some function libraries assume the data is in RAM. When a programmer wants to call such functions with data that is actually in ROM, the data is first temporarily copied to a buffer in RAM. This technique uses the minimum amount of ROM to hold the library, but it uses more ROM and RAM than the other techniques at every function call that involves data in ROM.

(3) Some function libraries use functions that can handle being called from one place with a string in RAM, and from other places with a string in ROM. This typically requires "fat pointers" that have extra bits that indicate whether the pointer is pointing to something in RAM or ROM. Every time such a library uses a pointer, the executing code checks those bits to see whether to execute the "read from RAM" or "read from ROM" instructions.

volatile

A "volatile" in a variable declaration tells us and the compiler that the value of that variable may change at any time, by some means outside this C program.

The "volatile" keyword tells the compiler not to make certain optimizations that only work with "normal" variables stored in RAM or ROM that are completely under the control of this C program.

The entire point of embedded programming is its communications with the outside world -- and both input and output devices require the "volatile" keyword.

There are at least 3 types of optimizations that "volatile" turns off:

- "read" optimizations -- without "volatile", C compilers assume that once the program reads a variable into a register, it doesn't need to re-read that variable every time the source code mentions it, but can use the cached value in the register. This works great with normal values in ROM and RAM, but fails miserably with input

peripherals. The outside world, and internal timers and counters, frequently change, making the cached value stale and irrelevant.

- "write" optimizations -- without "volatile", C compilers assume that it doesn't matter what order writes occur to different variables, and that only the last write to a particular variable really matters. This works great with normal values in RAM, but fails miserably with typical output peripherals. Sending "turn left 90, go forward 10, turn left 90, go forward 10" out the serial port is completely different than "optimizing" it to send "0" out the serial port.
- instruction reordering -- without "volatile", C compilers assume that they can reorder instructions. The compiler may decide to change the order in which variables are assigned to make better use of registers. This may fail miserably with IO peripherals where you, for example, write to one location to acquire a sample, then read that sample from a different location. Reordering these instructions would mean the old/stale/undefined sample is 'read', then the peripheral is told to acquire a new sample (which is ignored).

Depending on your hardware and compiler capabilities, other optimizations (SIMD, loop unrolling, parallelizing, pipelining) may also be affected.

const volatile

Many people don't understand the combination of "const" and "volatile". As we discussed earlier in Embedded Systems/Memory, embedded systems have many kinds of memory.

Many input peripherals -- such as free-running timers and keypad interfaces -- must be declared "const volatile", because they both (a) change value outside by means outside this C program, and also (b) this C program should not write values to them (it makes no sense to write a value to a 10-key keypad).

compiled and interactive

The vast majority of the time, when people write code in C, they run that code through C compiler on some personal computer to get a native executable. People working with embedded systems then download that native executable to the embedded system, and run it.

However, a few people working with embedded systems do things a little differently.

- Some use a C interpreter such as PicoC^[5] or Wikipedia: Interactive C. They download the C source code to the embedded system, then they run the interpreter in the embedded system itself.
- Some people have the luxury of working with "large" embedded systems that can run a standard C compiler (it runs the standard GCC on Linux or BSD; or it runs the Wikipedia: DJGPP port of GCC on FreeDos; or it runs the Wikipedia: MinGC port of GCC on Windows; or it runs the Wikipedia: Tiny C Compiler on Linux or Windows; or some other C compiler). They download the C source code to the embedded system, then they run the compiler in the embedded system itself.

C compilers for embedded systems

Perhaps the biggest difference between C compilers for embedded systems and C compilers for desktop computers is the distinction between the "platform" and the "target". The "platform" is where the C compiler runs -- perhaps a laptop running Linux or a desktop running Windows. The "target" is where the executable code generated by the C compiler will run -- the CPU in the embedded system, often without any underlying operating system.

The GCC compiler is^[citation needed] the most popular C compiler for embedded systems. GCC was originally developed for 32-bit Princeton architecture CPUs. So it was relatively easily ported to target ARM core microcontrollers such as XScale and Atmel AT91RM9200; Atmel AVR32 AP7 family; MIPS core microcontrollers such as the Microchip PIC32; and Freescale 68k/ColdFire processors.

The people who write compilers have also (with more difficulty) ported GCC to target the Texas Instruments MSP430 16-bit MCUs; the Microchip PIC24 and dsPIC 16-bit Microcontrollers; the 8-bit Atmel AVR microcontrollers; the 8-bit Freescale 68HC11 microcontrollers.

Other microcontrollers are very different from a 32-bit Princeton architecture CPU. Many compiler writers have decided it would be better to develop an independent C compiler rather than try to force the round peg of GCC into the square hole of 8-bit Harvard architecture microcontroller targets:

SDCC - Small Device C Compiler for the Intel 8051, Maxim 80DS390, Zilog Z80, Motorola 68HC08, Microchip PIC16, Microchip PIC18 <http://sdcc.sourceforge.net/>

There are some highly respected companies that sell commercial C compilers. You can find such a commercial C compiler for practically every microcontroller, including the above-listed microcontrollers. Popular microcontrollers not already listed (i.e., microcontrollers for which the only known C compiler is a commercial C compiler) include the Cypress M8C MCUs; Microchip PIC10 and Microchip PIC12 MCUs; etc.

Further reading

- [Wikipedia:bit field](#)
- [Wiki:BitField](#)
- [C Programming/Variables](#) and [C++ Programming/Variables](#) also discuss "const" and "volatile" variables
- [ARM technical support FAQ: Use of 'const' and 'volatile'](#) ^[5]
- ["Volatile as a promise"](#) ^[6] article by Dan Saks
- [Nullstone: "Volatile"](#) ^[7] "Empirical data suggests that incorrect optimization of volatile objects is one of the most common defects in C optimizers."
- Some of many incorrect understandings of combining "const" and "volatile": [\[8\]](#), [\[9\]](#), ...
- ["Use of volatile"](#) ^[10] by Ashok K. Pathak
- [The Wikipedia: Small Device C Compiler supports several popular microcontrollers. SDCC is the only open source C compiler for Intel 8051-compatible microcontrollers.](#)
- ["Free C/C++ Compilers & Cross-Compilers for MicroControllers"](#) ^[11]

References

- [1] <http://publib.boulder.ibm.com/infocenter/macxhelp/v6v81/index.jsp?topic=/com.ibm.vacpp6m.doc/language/ref/clrc03defbitf.htm>
- [2] http://gcc.gnu.org/onlinedocs/gcc-4.2.2/gcc/Structures-unions-enumerations-and-bit_002dfields-implementation.html#Structures-unions-enumerations-and-bit_002dfields-implementation
- [3] "Data in Program Space: A Note On const" (http://www.nongnu.org/avr-libc/user-manual/pgmspace.html#pgmspace_const)
- [4] "BoostC C Compiler for PICmicro Reference Manual" (<http://sourceboost.com/Products/BoostC/Docs/boostc.pdf>)
- [5] <http://www.arm.com/support/faqdev/1485.html>
- [6] <http://www.embedded.com/columns/programmingpointers/175801310>
- [7] <http://nullstone.com/htmls/category/volatile.htm>
- [8] <http://www.openasthra.com/c-tidbits/static-volatile-const-int-x1-valid/>
- [9] <http://en.allexperts.com/q/C-1587/constant-volatile.htm>
- [10] <http://www.programmersheaven.com/articles/pathak/article1.htm>
- [11] <http://www.thefreecountry.com/compilers/cpp-microcontrollers-pda.shtml>

Embedded Systems/Assembly Language

This book will demonstrate techniques for programming embedded systems in assembly language.

x86 Assembly Review

Main page: X86 Assembly

The x86 microprocessor has (at least):

4 general purpose registers

AX, BX, CX, and DX. AX is the fast accumulator.

4 segment registers

CS (code section), DS (data section), ES (extra section), SS (stack section).

5 pointer registers

SI (source index), DI (destination index), IP (instruction pointer), SP (stack pointer), BP (base pointer).

1 flag register

Flags ('7' flags like Zero flag, Carry flag)

Unlike "memory-mapped" processors, the x86 has special "I/O" instructions (inp, outp) intended to talk to I/O hardware.

ARM assembly review

Main page: Embedded Systems/ARM Microprocessors

At any one time, 17 registers can be accessed: R0 to R14 (which have identical hardware), R15, and the status register CPSR.

(To reduce latency on interrupt handling, these registers and the SPSR "saved program status register" are "shadowed" during interrupts. Including those shadows, the typical ARM processor has a total of 37 registers).

The standard C calling convention for ARM ^[citation needed] is:

- R15: PC: program counter
- R14: LR: link register (holds return address for most recent subroutine call)
- R13: SP: stack pointer (for nested subroutine calls)
- R12-R4: long-term variables: used by a subroutine only if it restores the original values before it returns
- R3-R0: scratch-pad variables and subroutine-call parameters and subroutine-return results.

I/O hardware is typically "memory mapped".

Word Length

Modern desktop PCs are almost all 32 bit machines, and the next generation of processors is going to be fully 64 bit. This is all well and good for the average programmer, but what do you do when you are in an embedded situation with a microcontroller the size of your finger nail that is capable of only 4 bit arithmetic? 32 bits may be the norm in the desktop market, but there is no gold standard in embedded chips: more bits take up more space and costs more money. In essence, it is the job of a good embedded systems engineer to find the smallest, cheapest microcontroller that does the job that needs to get done. Consider the following table:

bits	biggest unsigned number	biggest signed number	smallest signed number*
4	15	7	-8
8	255	127	-128
16	65,535	32,767	-32,768

* 2's compliment format

Even the 16 bit processor is a far cry from the 4 billion integer range of a standard 32 bit processor. Let's say that we have a 4 bit microcontroller with 4 available internal registers (4 bit each), and 256 bytes of onboard programmable memory. This processor cannot handle anything but the most simple tasks! What if we need to manipulate an 8-bit number on this little microprocessor? for instance, what if we want to make a digital clock with it? the 4 bit microprocessor is going to need to handle numbers up to and including 59 (the number of minutes displayed before the next hour). This is going to require more then the 4 bits allotted, in fact it is going to require at least 6 bits of space. What we need to do then, is come up with a way to treat 2 separate small registers as if they are a single large register. This chapter will talk about that subject a little bit.

For further reading

- Assembly Language
- AVR Assembler^[1]

References

[1] <http://avr-asm.tripod.com/>

Embedded Systems/Mixed C and Assembly Programming

C and Assembly

Many programmers are more comfortable writing in C, and for good reason: C is a mid-level language (in comparison to Assembly, which is a low-level language), and spares the programmers some of the details of the actual implementation.

However, there are some low-level tasks that either can be better implemented in assembly, or can *only* be implemented in assembly language. Also, it is frequently useful for the programmer to look at the assembly output of the C compiler, and hand-edit, or *hand optimize* the assembly code in ways that the compiler cannot. Assembly is also useful for time-critical or real-time processes, because unlike with high-level languages, there is no ambiguity about how the code will be compiled. The timing can be strictly controlled, which is useful for writing simple device drivers. This section will look at multiple techniques for mixing C and Assembly program development.

Inline Assembly

One of the most common methods for using assembly code fragments in a C programming project is to use a technique called **inline assembly**. Inline assembly is invoked in different compilers in different ways. Also, the assembly language syntax used in the inline assembly depends entirely on the assembly engine used by the C compiler. Microsoft C++, for instance, only accepts inline assembly commands in MASM syntax, while GNU GCC only accepts inline assembly in GAS syntax(also known as AT&T syntax) . This page will discuss some of the

basics of mixed-language programming in some common compilers.

Linked assembly

When an assembly source file is assembled by an assembler, and a C source file is compiled by a C compiler, those two **object files** can be linked together by a **linker** to form the final executable. The beauty of this approach is that the assembly files can be written using any syntax and assembler that the programmer is comfortable with. Also, if a change needs to be made in the assembly code, all of that code exists in a separate file, that the programmer can easily access. The only disadvantages of mixing assembly and C in this way are that a) both the assembler and the compiler need to be run, and b) those files need to be manually linked together by the programmer. These extra steps are comparatively easy, although it does mean that the programmer needs to learn the command-line syntax of the compiler, the assembler, and the linker.

Inline Assembly vs. linked assembly

Advantages of inline assembly:

Short assembly routines can be embedded directly in a C function in a C code file. The mixed-language file then can be completely compiled with a single command to the C compiler (as opposed to compiling the assembly code with an assembler, compiling the C code with the C Compiler, and then linking them together). This method is fast and easy. If the in-line assembly is embedded in a function, then the programmer doesn't need to worry about `#Calling_Conventions`, even when changing compiler switches to a different calling convention.

Advantages of linked assembly:

If a new microprocessor is selected, all the assembly commands are isolated in a ".asm" file. The programmer can update just that one file -- there is no need to change any of the ".c" files (if they are portably written).

Calling Conventions

When writing separate C and Assembly modules, and linking them with your linker, it is important to remember that a number of high-level C constructs are very precisely defined, and need to be handled correctly by the assembly portions of your program. Perhaps the biggest obstacle to mixed-language programming is the issue of function calling conventions. C functions are all implemented according to a particular convention that is selected by the programmer (if you have never "selected" a particular calling convention, it's because your compiler has a default setting). This page will go through some of the common calling conventions that the programmer might run into, and will describe how to implement these in assembly language.

Code compiled with one compiler won't work right when linked to code compiled with a different calling convention. If the code is in C or another high-level language (or assembly language embedded in-line to a C function), it's a minor hassle -- the programmer needs to pick which compiler / optimization switches she wants to use *today*, and recompile every part of the program that way. Converting assembly language code to use a different calling convention takes more manual effort and is more bug-prone.

Unfortunately, calling conventions are often different from one compiler to the next -- even on the same CPU. Occasionally the calling convention changes from one version of a compiler to the next, or even from the same compiler when given different "optimization" switches.

Unfortunately, many times the calling convention used by a particular version of a particular compiler is inadequately documented. So assembly-language programmers are forced to use reverse engineering techniques to figure out the exact details they need to know in order to call functions written in C, and in order to accept calls from functions written in C.

The typical process is:

- write a ".c" file with stubs ... *details???* ... exactly the same number and type of inputs and outputs that you want the assembly-language function to have.
- Compile that file with the appropriate switches to give a mixed assembly-language-with-c-in-comments file (typically a ".cod" file). (If your compiler can't produce an assembly language file, there is the tedious option of disassembling the binary ".obj" machine-code file).
- Copy that ".cod" file to a ".asm" file. (Sometimes you need to strip out the compiled hex numbers and comment out other lines to turn it into something the assembler can handle).
- Test the calling convention -- compile the ".asm" file to an ".obj" file, and link it (instead of the stub ".c" file) to the rest of the program. Test to see that "calls" work properly.
- Fill in your ".asm" file -- the ".asm" file should now include the appropriate header and footer on each function to properly implement the calling convention. Comment out the stub code in the middle of the function and fill out the function with your assembly language implementation.
- Test. Typically a programmer single-steps through each instruction in the new code, making sure it does what they wanted it to do.

Parameter Passing

Normally, parameters are passed between functions (either written in C or in Assembly) via the stack. For eg. if a function foo1() calls a function foo2() with 2 parameters (say characters x and y), then before the control jumps to the starting of foo2(), two bytes (normal size of a character in most of the systems) are filled with the values that need to be passed. Once control jumps to the new function foo2(), and you use the values (passed as parameters) in the function, they are retrieved from the stack and used.

There are two parameter passing techniques in use,

1. Pass by Value
2. Pass by Reference

Parameter passing techniques can also use

- right-to-left (C-style)
- left-to-right (Pascal style)

On processors with lots of registers (such as the ARM and the Sparc), the standard calling convention puts **all** the parameters (and even the return address) in registers.

On processors with inadequate numbers of registers (such as the 80x86 and the M8C), all calling conventions are forced to put at least some parameters on the stack or elsewhere in RAM.

Some calling conventions allow "re-entrant code".

Pass by Value

With pass-by-value, a copy of the actual value (the literal content) is passed. For example, if you have a function that accepts two characters like

```
void foo(char x, char y){ x = x + 1; y = y + 2; putchar(x); putchar(y); }
```

 and you invoke this function as follows `char a,b; a='A'; b='B'; foo(a,b);` then the program pushes a copy of the ASCII values of 'A' and 'B' (65 and 66 respectively) onto the stack before the function foo is called. You can see that there is no mention of variables 'a' or 'b' in the function foo(). So, any changes that you make to those two values in foo will not affect the values of a and b in the calling function.

Pass by Reference

Imagine a situation where you have to pass a large amount of data to a function and apply the modifications, done in that function, to the original variables. An example of such a situation might be a function that converts a string with lower case alphabets to upper case. It would be an unwise decision to pass the entire string (particularly if it is a big one) to the function, and when the conversion is complete, pass the entire result back to the calling function. Here we pass the address of the variable to the function. This has two advantages, one, you don't have to pass huge data, thereby saving execution time and two, you can work on the data right away so that by the end of the function, the data in the calling function is already modified.

But remember, any change you make to the variable passed by reference will result in the original variable getting modified. If that's not what you wanted, then you must manually copy the variable before calling the function.

80x86 / Pentium

... do I need to say anything about compact/small/large/huge here? ...

AVR

WARNING!! Those who know a thing or two about copyright issues, should check if I didn't just do something wrong. The next segment was copy-pasted from http://www.nongnu.org/avr-libc/user-manual/FAQ.html#faq_reg_usage ^[1]

What registers are used by the C compiler?

Data types

char is 8 bits, int is 16 bits, long is 32 bits, long long is 64 bits, float and double are 32 bits (this is the only supported floating point format), pointers are 16 bits (function pointers are word addresses, to allow addressing the whole 128K program memory space on the ATmega devices with > 64 KB of flash ROM). There is a -mint8 option (see Options for the C compiler avr-gcc) to make int 8 bits, but that is not supported by avr-libc and violates C standards (int must be at least 16 bits). It may be removed in a future release.

Call-used registers (r18-r27, r30-r31)

May be allocated by gcc for local data. You may use them freely in assembler subroutines. Calling C subroutines can clobber any of them - the caller is responsible for saving and restoring.

Call-saved registers (r2-r17, r28-r29)

May be allocated by gcc for local data. Calling C subroutines leaves them unchanged. Assembler subroutines are responsible for saving and restoring these registers, if changed. r29:r28 (Y pointer) is used as a frame pointer (points to local data on stack) if necessary. The requirement for the callee to save/preserve the contents of these registers even applies in situations where the compiler assigns them for argument passing.

Fixed registers (r0, r1)

Never allocated by gcc for local data, but often used for fixed purposes:

r0 - temporary register, can be clobbered by any C code (except interrupt handlers which save it), may be used to remember something for a while within one piece of assembler code

r1 - assumed to be always zero in any C code, may be used to remember something for a while within one piece of assembler code, but must then be cleared after use (clr r1). This includes any use of the [f]mul[s[u]] instructions, which return their result in r1:r0. Interrupt handlers save and clear r1 on entry, and restore r1 on exit (in case it was non-zero).

Function call conventions

Arguments - allocated left to right, r25 to r8. All arguments are aligned to start in even-numbered registers (odd-sized arguments, including char, have one free register above them). This allows making better use of the movw instruction on the enhanced core.

If too many, those that don't fit are passed on the stack.

Return values: 8-bit in r24 (not r25!), 16-bit in r25:r24, up to 32 bits in r22-r25, up to 64 bits in r18-r25. 8-bit return values are zero/sign-extended to 16 bits by the caller (unsigned char is more efficient than signed char - just clr r25).

Arguments to functions with variable argument lists (printf etc.) are all passed on stack, and char is extended to int.

Warning: There was no such alignment before 2000-07-01, including the old patches for gcc-2.95.2. Check your old assembler subroutines, and adjust them accordingly.

Microchip PIC

Unfortunately, several different (incompatible) calling conventions are used in writing programs for the Microchip PIC ^[2].

And several "features" of the PIC architecture make most subroutine calls require several instructions -- much more verbose than the single instruction on many other processors.

The calling convention must deal with:

- The "paged" flash program memory architecture
- limitations on the hardware stack (perhaps by simulating a stack in software)
- the "paged" RAM data memory architecture
- making sure a subroutine call by an interrupt routine doesn't scramble information needed after the interrupt returns to the main loop.

Sparc

The Sparc has special hardware that supports a nice calling convention:

A "register window" ...

further reading

- "Instruction Set Simulation in C" ^[3] by Robert Gordon 2002 -- describes gradually converting from a pure C algorithm to a mixed assembly and C language for testing.
- "Interfacing Assembly and C Source Files - AN2129" ^[4] describes mixing C and assembly language code on a Cypress PSoC processor.
- "Inline Assembler Cookbook" ^[5] describes mixing C and assembly language code on an Atmel AVR processor.

External Links

- Calling C/C++ function from ASM code ^[6]
- OS development: "C++ to ASM linkage in GCC" ^[7]

References

- [1] http://www.nongnu.org/avr-libc/user-manual/FAQ.html#faq_reg_usage
- [2] <http://techref.massmind.org/techref/microchip/pages.htm>
- [3] <http://www.embedded.com/story/OEG20020226S0045>
- [4] <http://www.cypress.com/psoc2/?id=1353&rtID=76&rlD=2610>
- [5] http://www.nongnu.org/avr-libc/user-manual/inline_asm.html
- [6] <http://www.expertcore.org/viewtopic.php?f=12&t=478>
- [7] http://wiki.osdev.org/C%2B%2B_to_ASM_linkage_in_GCC

Embedded Systems/IO Programming

An embedded system is useless if it cannot communicate with the outside world. To this effect, embedded systems need to employ I/O mechanisms to both receive outside data, and transmit commands back to the outside world. Few Computer Science courses will even mention I/O programming, although it is a central feature of embedded systems programming. This chapter then will serve as a crash course on I/O programming, both for those with a background in C, and also for those without it.

Dos.h

The Dos.h header file commonly included in many C distributions, especially on DOS and Windows systems. This file contains information on a number of different routines, but most importantly it contains prototypes for the `inp()` and `outp()` functions that can be used to provide port output directly from a C program. Many embedded systems however, will not have a Dos.h header file in their library, nor will they have any precompiled C routines to handle port input and output. The purpose of this chapter then, is to teach the reader how to "brew their own" input and output routines.

The <iohw.h> interface

Some C compiler distributions include the <iohw.h> interface. It allows relatively portable hardware device driver code to be written. It is used to implement the standard C++ <hardware> interface. ^[1]

x86 Output Routines

The x86 instruction set contains 2 instructions: **in** and **out** both functions take 2 arguments, a port number, and then another parameter to receive the data or to send the data from (depending on which command you use).

we can define 2 functions in assembly, using the CDECL calling convention, that we can link with our C programs, and call from our C programmes to handle port output and input.

Synchronous and Asynchronous

Data can be transmitted either synchronously or asynchronously. **synchronous** transmissions are transmissions that are sent with a clock signal. This way the receiver knows exactly where each bit begins and ends. This way, there is less susceptibility to noise and **jitter**. Also, synchronous transmissions frequently require extensive hand-shakeing between the transmitter and receiver, to ensure that all timing mechanisms are synchronized together. Conversely, **asynchronous** transmissions are sent without a clock signal, and often without much hand-shaking.

References

[1] "Technical Report on C++ Performance" (<http://www.research.att.com/~bs/performanceTR.pdf>) by Dave Abrahams et. al. 2003

Embedded Systems/Serial and Parallel IO

This page of the Embedded Systems book is a stub. You can help by expanding this section.

Data Transmission

Data can be sent either serially, one bit after another through a single wire, or in parallel, multiple bits at a time, through several parallel wires. Most famously, these different paradigms are visible in the form of the common PC ports "serial port" and "parallel port". Early parallel transmission schemes often were much faster than serial schemes (more wires = more data faster), but the added cost and complexity of hardware (more wires, more complicated transmitters and receivers). Serial data transmission is much more common in new communication protocols due to a reduction in the I/O pin count, hence a reduction in cost. Common serial protocols include SPI, and I²C. Surprisingly, serial transmission methods can transmit at much higher clock rates per bit transmitted, thus tending to outweigh the primary advantage of parallel transmission. Parallel transmission protocols are now mainly reserved for applications like a CPU bus or between IC devices that are physically very close to each other, usually measured in just a few centimeters. Serial protocols are used for longer distance communication systems, ranging from shared external devices like a digital camera to global networks or even interplanetary communication for space probes, however some recent CPU bus architectures are even using serial methodologies as well.

Serial Transmission

RS-232

See Also

- Serial Programming Book

RS-485

See also

- Serial Programming/RS-485

I2C Inter-Integrated Circuit

See Also

I2C (Inter-Integrated Circuit) Bus Technical Overview and Frequently Asked Questions ^[1]

Ethernet

As on-chip memory increases, it is becoming more common to see Ethernet support in small system-on-chip embedded systems. New Ethernet ASIC products are also on the market. This allows an embedded system to have it's own IP address on a network or on the internet. It can act as a server for its own webpage, to implement a GUI or general purpose I/O, and to display any relevant information such as sensor data, or even as a portal to remotely upgrade firmware. For example, many network routers have these features.

USB

See Also

- Serial Programming/USB (Currently, Q1/2006, the module is a stub)

Serial ATA

See Also

- Serial Programming/Serial ATA (Currently, Q1/2006, the module is a stub)

Parallel Transmission

Centronics

Centronics is synonymous with the 1980's PC standard parallel printer interface.

For further reading

- Robotics/Computer Control/The Interface/Networks

References

- [1] <http://www.esacademy.com/faq/i2c/>

Embedded Systems/Super Loop Architecture

When programming an embedded system, it is important to meet the time deadlines of the system, and to perform all the tasks of the system in a reasonable amount of time, but also in a good order. This page will talk about a common program architecture called the **Super-Loop Architecture**, that is very useful in meeting these requirements

Definition

A super loop is a program structure comprised of an infinite loop, with all the tasks of the system contained in that loop. Here is a general pseudocode for a superloop implementation:

```
Function Main_Function()  
{  
    Initialization();  
    Do_Forever  
    {  
        Check_Status();  
        Do_Calculations();  
        Output_Response();  
    }  
}
```

We perform the initialization routines before we enter the super loop, because we only want to initialize the system once. Once the infinite loop begins, we don't want to reset the values, because we need to maintain persistent state in the embedded system.

The loop is in fact a variant of the classic "batch processing" control flow: Read input, calculate some values, write out values. Do it until you run out of input data "cards". So, embedded systems software is not the only type of software which uses this kind of architecture. For example, computer games often use a similar loop. There the loop is called (*tight*) (*main*) *game loop*.

Power-Save Super Loop

Let's say we have an embedded system which has an average loop time of 1ms, and needs only to check a certain input once per second. It seems a waste to continue looping the program, especially when we don't need to do anything most of the time. In this situation, the program will loop 1000 times before it needs to read the input, and the other 999 loops of the program will just be a countdown to the next read. In this case, it is sorely inefficient to have the processor chugging away at 100% capacity all the time. We will now implement an expanded superloop to build in a delay:

```
Function Main_Function()  
{  
    Initialization();  
    Do_Forever  
    {  
        Check_Status();  
        Do_Calculations();  
        Output_Response();  
        Delay_For_Next_Loop();  
    }  
}
```

```
}

```

Notice how we added a delay at the end of the super loop? If we build this delay to delay for 999ms, we don't need to loop 1000 times, we can read the input on every loop.

Also, it is important to note that many microcontrollers have power-save modes, where they will require less electrical power, which can be especially good if the system is running off a battery.

Power Use Calculations

Let's say that we have a microcontroller that uses 20mA of current in "normal mode", but only needs 5mA of power in "Low-Power Mode". Let's also say that we are using the example superloop above, which is in "Low-Power Mode" 99.9% of the time (1ms of calculations every second), and is only in normal mode 0.1% of the time:

$$Power = \frac{(99.9\% \times 5mA) + (0.1\% \times 20mA)}{100\%} = 5.015mA \quad \textit{Average}$$

Notice how we can cut down our power consumption by adding in a substantial delay? This is especially important because few embedded applications will require 100% of processor resources. Most embedded systems are able to just sit and wait in a low-power state until needed.

Embedded Systems/Protected Mode and Real Mode

x86 Processor Modes

Real mode and protected mode are two operating modes of the Intel x86 processor. However, there are certain other modes as well.

V86 (Virtual 86 mode)

This is the mode in which DOS applications run on Windows machine. This was done mainly to maintain compatibility with older DOS applications.

SMM (System Management Mode)

This mode was introduced, as the name suggests, for managing the system transparently without applications or OS getting the hint of it. Its primarily meant to be used by the BIOS code.

Big Real Mode

Now this mode is more like Real mode, but in this we can access full 4Gb address space of the 32-bit processor.

However in this page, we will be focussing mainly on Real mode and Protected mode only.

Real Mode

This is the only mode which was supported by the 8086 (the very first processor of the x86 series). The 8086 had 20 address lines, so it was capable of addressing "2 raised to the power 20" i.e. 1 MB of memory.

Protected Mode

This is the mode used most commonly by modern 32-bit operating systems.

Entering Protected Mode

For instructions to enter protected mode, see: X86 Assembly/Protected Mode.

Embedded Systems/Bootloaders and Bootsectors

To simplify many tasks, programmers for many systems will often employ a generic piece of software called a **bootloader** that will set some system settings (such as enabling protected mode), and then will be used to load the kernel, and then transfer control to the kernel for system operation. In embedded systems particularly, bootloaders are useful when doing work on the kernel: the kernel can be altered and tested, and the bootloader will automatically load each new version into memory.

To further simplify the process, the programmer can employ a tool called a **bootmenu**, which is essentially a bootloader that allows the user to select which kernel to load, from a list of possibilities. This is useful when multiple kernels are being compared, or when different versions of the same kernel are being debugged.

Bootloaders are used on many microcontrollers. A bootloader is often the fastest way to update a program in a microcontroller with small changes. That makes the edit-compile-download-test cycle a little bit faster.

The microcontroller can also have minimal hard-coded silicon dedicated to a simpler programming interface, which needs an expensive programmer socket. A vendor can then put a tiny program in Flash which reads the real program through the interface-du-jour, be it RS-232, I²C^[1], or wireless USB.

Further Reading

- [Wikipedia:RedBoot](#)
- [x86 Assembly/Bootloaders](#)
- [AVR bootloader^{\[2\]}](#)
- [PIC bootloaders^{\[3\]}](#)
 - [PIC16f877 Monitor on Linux^{\[4\]}](#)
 - [USB PIC18 microcontroller bootloader^{\[5\]}: download new firmware over USB.](#)
- [USB bootloader for Cypress PSoC microcontrollers^{\[6\]}](#)

References

- [1] <http://en.wikipedia.org/wiki/I2C>
- [2] <http://www.cmeter.org/CVmegaload/index.html>
- [3] <http://massmind.org/techref/microchip/devprogs.htm#bootloaders>
- [4] <http://www.wsu.edu/~jackdollar/jmon/index.htm>
- [5] <http://www.diolan.com/pic/bootloader.html>
- [6] <http://www.psocdeveloper.com/forums/viewtopic.php?t=1021>

Embedded Systems/Terminate and Stay Resident

In the original DOS operating system, there was no capability for multi-threading, or multi-process mechanisms. However, it was found to be very beneficial to leave certain components in memory even after the process that created it ended. These program fragments were known as **Terminate and Stay Resident** modules, and were the precursors to the dynamic library infrastructure of current Windows operating systems. TSR routines are often used to implement device drivers, or common library functions.

Real Time Operating Systems

Embedded Systems/Real-Time Operating Systems

A **Real-Time Operating System** (RTOS) is a computing environment that reacts to input within a specific time period. A real-time deadline can be so small that system reaction appears instantaneous. The term real-time computing has also been used, however, to describe "slow real-time" output that has a longer, but fixed, time limit.

Learning the difference between real-time and standard operating systems is as easy as imagining yourself in a computer game. Each of the actions you take in the game is like a program running in that environment. A game that has a real-time operating system for its environment can feel like an extension of your body because you can count on a specific "lag time:" the time between your request for action and the computer's noticeable execution of your request. A standard operating system, however, may feel disjointed because the lag time is unreliable. To achieve time reliability, real-time programs and their operating system environment must prioritize deadline actualization before anything else. In the gaming example, this might result in dropped frames or lower visual quality when reaction time and visual effects conflict.

Methods

An operating system is considered real-time if it invariably enables its programs to perform tasks within specific time constraints, usually those expected by the user. To meet this definition, some or all of the following methods are employed:

- The RTOS performs few tasks, thus ensuring that the tasks will always be executed before the deadline
- The RTOS drops or reduces certain functions when they cannot be executed within the time constraints ("load shedding")
- The RTOS monitors input consistently and in a timely manner
- The RTOS monitors resources and can interrupt background processes as needed to ensure real-time execution
- The RTOS anticipates potential requests and frees enough of the system to allow timely reaction to the user's request
- The RTOS keeps track of how much of each resource (CPU time per timeslice, RAM, communications bandwidth, etc.) might possibly be used in the worst-case by the currently-running tasks, and refuses to accept a new task unless it "fits" in the remaining un-allocated resources.

Chapters in this section will discuss how an RTOS works, some general methods for working with an RTOS, and a few popular RTOSes. Finally, in some later chapters, we will discuss how to write your own RTOS.

Objectives

An RTOS must respond in a timely manner to changes, but that does not necessarily mean that an RTOS can handle a large throughput of data. In fact in an RTOS, small response times are valued much higher than power, or data speed. Sometimes an RTOS will even need to drop data to ensure that it meets its strict deadlines. In essence, that provides us with a perfect definition: **an RTOS is an operating system designed to meet strict deadlines.** Beyond that definition, there are few requirements as to what an RTOS must be, or what features it must have. Some RTOS implementations are very powerful and very robust, while other implementations are very simple, and suited for only one particular purpose.

An RTOS may be either event-driven or time-sharing. An **event-driven RTOS** is a system that changes state only in response to an incoming event. A **time-sharing RTOS** is a system that changes state as a function of time

The Fundamentals

To most people, embedded systems are not recognizable as computers. Instead, they are hidden inside everyday objects that surround us and help us in our lives. Embedded systems typically do not interface with the outside world through familiar personal computer interface devices such as a mouse, keyboard and graphic user interface. Instead, they interface with the outside world through unusual interfaces such as sensors, actuators and specialized communication links. Real-time and embedded systems operate in constrained environments in which computer memory and processing power are limited. They often need to provide their services within strict time deadlines to their users and to the surrounding world. It is these memory, speed and timing constraints that dictate the use of real-time operating systems in embedded software.

Real-Time Kernel

The heart of a real-time OS (and the heart of every OS, for that matter) is the **kernel**. A kernel is the central core of an operating system, and it takes care of all the OS jobs:

1. Booting
2. Task Scheduling
3. Standard Function Libraries

Now, we will talk about booting and bootloaders later, and we will also devote several chapters to task scheduling. So we should mention at least one thing about standard function libraries: In an embedded system, there is rarely enough memory (if any) to maintain a large function library. If functions are going to be included, they must be small, and important.

In an embedded system, frequently the kernel will boot the system, initialize the ports and the global data items. Then, it will start the scheduler and instantiate any hardware timers that need to be started. After all that, the Kernel basically gets dumped out of memory (except for the library functions, if any), and the scheduler will start running the child tasks.

Basic Kernel Services

In the discussion below, we will focus on the "kernel" – the part of an operating system that provides the most basic services to application software running on a processor. The "kernel" of a real-time operating system ("RTOS") provides an "abstraction layer" that hides from application software the hardware details of the processor (or set of processors) upon which the application software will run.

For further reading

- Operating System Design
- "Operating systems on the rise" ^[1] by Jim Turley, *Embedded Systems Design* 2006-06-21. Survey results show that about 3/4 of all embedded system projects use some kind of an operating system. About 1/4 of all embedded system projects use no operating system at all (presumably using a Embedded Systems/Super Loop Architecture instead).

See Embedded Systems/Common RTOS for a list of common real-time operating systems.xxxx

References

[1] <http://www.embedded.com/showArticle.jhtml?articleID=187203732>

Embedded Systems/Threading and Synchronization

One of the most useful developments in the history of computing is multitasking and multithreading. This technique isn't always available to an embedded system engineer, but some embedded systems and RTOS have multithreading (MT) capability. The chapters in this section will talk about some of the uses of MT, and will discuss some of the common pitfalls associated with MT programming. This page is only going to serve as a brief reference to multi-threaded programming.

Preemptive Multithreading

When the first multi-tasking systems were established, they did not have a central controller. Multi-tasking was established by having programs voluntarily give up control to the system, and the system would then give control to another process. This system worked reasonably well, except that any program that was misbehaving would slow down the entire system. For instance, if a program got stuck in an infinite loop, it would never give up control, and the system would freeze.

The solution to this problem is **preemptive multithreading**. In a preemptive environment, control could be moved from one process to another process at any given time. The process that was "preempted" would not even know that anything had happened, except maybe there would be a larger than average delay between 2 instructions. Preemptive multithreading allows for programs that do not voluntarily give up control, and it also allows a computer to continue functioning when a single process hangs.

There are a number of problems associated with preemptive multithreading that all stem from the fact that control is taken away from one process when it is not necessarily prepared to give up control. For instance, if one process were writing to a memory location, and was preempted, the next process would see half-written data, or even corrupted data in that memory location. Or, if a task was reading in data from an input port, and it was preempted, the timing would be wrong, and data would be missed from the line. Clearly, this is unacceptable.

The solution to this new problem then is the idea of synchronization. Synchronization is a series of tools provided by the preemptive multithreaded operating system to ensure that these problems are avoided. Synchronization tools can include timers, "critical sections," and locks. Timers can ensure that a given process may be preempted, but only for a certain time. Critical sections are commands in the code that prevent the system from switching control for a certain time. Locks are commands that prevent interference in atomic operations. These topics will all be discussed in the following chapters.

Mutexes

The term **Mutex** is short for "Mutual Exclusion", and is a type of mechanism used in a preemptive environment that can prevent unauthorized access to resources that are currently in use. Mutexes follow several rules:

1. Mutexes are system wide objects, that are maintained by the kernel.
2. Mutexes can only be owned by one process at a time
3. Mutexes can be acquired by asking the kernel to allocate that mutex to the current task
4. If a Mutex is already allocated, the request function will block until the mutex is available.

In general, it is considered good programming practice to release mutexes as quickly as possible. Some problems with mutexes will be discussed in the chapter on deadlocks.

Spin Locks

Spin locks is a quick form of synchronization methods. It is named after its behavior - spin in the loop while the condition is false. To implement spin lock system should support test-and-set ^[1] idiom or give exclusive access to a locking thread by any means (masking interrupts, locking bus).

An advantage of spin locks is that they are very simple. A disadvantage is that they waste CPU cycles in loop waiting. Most common use of spin locks is to synchronize quick access to objects. It is not advisable to do a long computations while spin locked a section.

Critical Sections

A critical section is a sequence of computer instructions that may malfunction if interrupted. An atomic operation is a sequence of computer instructions that cannot be interrupted and function correctly. In practice, these two subtly different definitions are often combined. Operating systems provide synchronization objects to meet these requirements, and some actually call these objects as "critical sections," "atomic operations" or "monitors."

An example of a critical section is code that removes data from a queue that is filled by an interrupt. If the critical section is not protected, the interrupt can occur while the dequeuing function is changing pointers, and corrupt the queue pointers. An example of an atomic operation is an I/O read where the process must read all the data at a particular rate, and cannot be preempted while reading.

A generally good programming practice is to have programs exit their critical sections as quickly as possible, because holding a critical section for too long will cause other processes on the system not to get any time, and will cause a major performance decrease. Critical sections should be used with care.

Priority Scheduling

Many RTOS have a mechanism to distinguish the relative priorities of different tasks. High-priority tasks are executed more frequently than the low priority tasks. Each implementation of priority scheduling will be a little different, however.

Deadlock

A **deadlock** occurs when a series of synchronization objects are held in a preemptive MT system in such a way that no process can move forward. Let us take a look at an example:

Let's say that we have 2 threads: T1 and T2. We also have 2 mutexes, M1 and M2.

1. T1 asks for and acquires mutex M1.
2. T2 acquires M2
3. T1 asks for M2, and the system transfers control to T2 until T2 releases M2.

4. T2 asks for M1, and the system is in deadlock (neither thread can continue until the other releases its mutex).

This is a very difficult problem to diagnose, and an even more difficult problem to fix. This chapter will provide some general guide-lines for preventing deadlocks.

Watchdog Timer

In an embedded environment, far away from the lab, and far away from the programmers, engineers, and technicians, all sorts of things can go wrong, and the embedded system needs to be able to fix itself. Remember, once you close the box, and shrink-wrap your product, it's hard to get back in there and fix your mistakes.

In a typical computer systems, cosmic rays flip a bit of RAM about once a month^[citation needed]. If that happens to the wrong bit, the program can "hang", stuck in a short infinite loop.

Turning the power off then on again gets it unstuck. But how do you jiggle the power switch when you are on Earth and your embedded system is near Neptune? Or you are in Paris, and your embedded system is in Antarctica?

One of the most important tools of an embedded systems engineer is the **Watch-Dog Timer** (WDT). A WDT is a timer with a very long fuse (several seconds, usually).

The WDT counts down toward zero(*), like the big red numbers counting down on the bombs in the movies. Left to itself, eventually the counter will reach zero. When the counter reaches zero, the WDT resets the microcontroller (as if the power were turned off, then turned back on).

When the system is running normally, you don't want it to randomly reset itself, so you need to make sure that your program always "feeds the watch-dog" long before time runs out. Good practice is to reset the WDT less than halfway-through its countdown. For instance, if the WDT has a timer of 20 seconds, then you will want to feed the WDT at least once every 10 seconds.

Unlike when our hero deals with bombs in the movies, feeding the watch-dog doesn't stop the countdown. When the code uses a "reset" or "clear" command to feed the watchdog, it merely sets the WDT back to some large number -- and then the watchdog timer immediately starts counting down from there.

If the programmer fails to feed the watchdog in time -- or if the program hangs for any reason -- then sooner or later WDT will time out, and the program will reset, hopefully getting your system unstuck.

(*) Some watchdogs count up. With this kind of watchdog, "feeding the watchdog" resets it to zero. If it ever reaches some high limit, it resets the system.

further reading

- Massmind: watch-dog timers ^[2]
- Wikipedia:watchdog timer
- Embedded Control Systems Design/DesignPatterns#Watchdog timer
- Linux Kernel Drivers Annotated/Character Drivers/Softdog Driver
- "the Grenade Timer: Fortifying the Watchdog Timer Against Malicious Mobile Code" ^[3] by Frank Stajano and Ross Anderson (2000) -- gives most of the benefits of "protected mode" hardware to "very low-cost microcontrollers" that don't have protected mode hardware, using "very frugal hardware resources".

References

- [1] <http://en.wikipedia.org/wiki/Test-and-set>
- [2] <http://massmind.org/techref/wdts.htm>
- [3] <http://www.cl.cam.ac.uk/~rja14/Papers/grenade.pdf>

Embedded Systems/Interrupts

Interrupts

Sometimes things will happen in a system when the processor is simply not ready. In fact, sometimes things change that require immediate attention. Can you imagine, sitting at your PC, that you were to hit buttons on the keyboard, and nothing happens on your computer?

Maybe the processor was busy, and it just didnt check to see if you were hitting any buttons at that time. The solution to this problem is something called an "Interrupt." Interrupts are events that cause the microprocessor to stop what it is doing, and handle a high-priority task first. After the interrupt is handled, the microprocessor goes back to whatever it was doing before. In this way, we can be assured that high-priority inputs are never ignored.

Hardware and Software

There are two types of interrupts: Hardware and Software. Software interrupts are called from software, using a specified command. Hardware interrupts are triggered by peripheral devices outside the microcontroller. For instance, your embedded system may contain a timer that sends a pulse to the controller every second. Your microcontroller would wait until this pulse is received, and when the pulse comes, an interrupt would be triggered that would handle the signal.

Interrupt Service Routines

Interrupt Service Routines (ISR) are the portions of the program code that handle the interrupt requests. When an Interrupt is triggered (either a hardware or software interrupt), the processor breaks away from the current task, moves the instruction pointer to the ISR, and then continues operation. When the ISR has completed, the processor returns execution to the previous location.

Many embedded systems are called **interrupt driven systems**, because most of the processing occurs in ISRs, and the embedded system spends most of it's time in a low-power mode.

Sometimes ISR may be split into two parts: top-half (fast interrupt handler, First-Level Interrupt Handler (FLIH)) and bottom-half (slow interrupt handler, Second-Level Interrupt Handlers (SLIH)). Top-half is a faster part of ISR which should quickly store minimal information about interrupt and schedule slower bottom-half at a later time.

Interrupt Vector Table

The "Interrupt Vector Table" is a list of every interrupt service routine. It is located at a fixed location in program memory.

(Some processors expect the interrupt vector table to be a series of "call" instructions, each one followed by the address of the ISR. Other processors expect the interrupt vector table to hold just the ISR addresses alone.)

You must make sure that every entry in the interrupt vector table is filled with the address of some actual ISR, even if it means making most of them point to the "do nothing and return from interrupt" ISR.

further reading

- [Wikipedia:interrupt vector](#)
- [Embedded_Control_Systems_Design/Operating_systems#Interrupts](#)
- [Operating System Design/Processes/Interrupt](#)

Embedded Systems/RTOS Implementation

The chapters in this section will discuss some of the general concepts involved in writing your own Real-Time Operating System. Readers may be able to read and understand the material in these pages without prior knowledge in operating system design and implementation, but a background knowledge in those subjects would certainly be helpful.

Memory Management

An important point to remember is that some embedded systems are locked away and expected to run for years on end without being rebooted. If we use conventional memory-management schemes to control memory allocation, we can end up with fragmented memory which can take valuable time to defragment and really is a major problem for tasks that are time-sensitive. This page then will talk about how to implement a memory management scheme in an RTOS, and will talk through to a basic implementation of `malloc()` and `free()`.

There are a variety of ways to deal with memory:

- Some systems never do a `malloc()` or `free()` -- all memory is allocated at compile time.
- Some systems use `malloc()` and `free()` with manual garbage collection.
- Some early automatic garbage collection schemes did a "stop the world" for several seconds during garbage collection and/or memory defragmentation. Such a system could miss real-time deadlines, which would be bad.
- Some later automatic garbage collection schemes do "incremental" garbage collection and memory defragmentation.

What is a Task

Embedded systems have a microprocessor connected to some piece of hardware (LEDs, buttons, limit switches, motors, serial port(s), battery chargers, etc.).

Each piece of hardware is generally associated with a little bit of software, called a "task". For example, "Check the keyboard and figure out which (if any) key has been pressed since the last check". Or "Check the current position of the spindle, and update the PID".

Often a task has a real-time limits, such as

- the motors must be shut off within 1/10 second after hitting the limit switch to avoid permanent damage
 - the PID loop must be updated at least every 1/100 second to avoid oscillation
-

- the MP3 player must decode a new sample at 44.1 KHz -- no faster, or it sounds chipmunk-like -- no slower, or it sounds like it's underwater.

Some embedded systems have only one task.

Other embedded systems have a single microcontroller connected to many different pieces of hardware -- they need to "multi-task".

What is the Scheduler

The "task scheduler" (or often "scheduler") is the part of the software that schedules which task to run next. The scheduler is the part of the software that chooses which task to run next.

The scheduler is arguably the most difficult component of an RTOS to implement. Schedulers maintain a table of the current state of each task on the system, as well as the current priority of each task. The scheduler needs to manage the timer too.

In general, there are 3 states that a task can be in:

1. Active. There can be only 1 active thread on a given processor at a time.
2. Ready. This task is ready to execute, but is not currently executing.
3. Blocked. This task is currently waiting on a lock or a critical section to become free.

Some systems even allow for other states:

1. Sleeping. The task has voluntarily given up control for a certain period of time.
2. Low-Priority. This task only runs when all other tasks are blocked or sleeping.

There are 2 ways the scheduler is called:

- the current task voluntarily yield(s) to the scheduler, calling the scheduler directly, or
- the current task has run "long enough", the timer hardware interrupts it, and the timer interrupt routine calls the scheduler.

The scheduler must save the current status of the current task (save the contents of all registers to a specified location), it must look through the list of tasks to find the highest priority task in the Ready state, and then must switch control back to that task (by restoring it's register values from memory).

The scheduler should first check to ensure that it is enabled. If the scheduler is disabled, it shouldn't preempt the current thread. This can be accomplished by checking a current global flag value. Some functions will want to disable the scheduler, so this flag should be accessible by some accessor method. An alternate method to maintaining a global flag is simply to say that any function that wants to disable the scheduler can simply disable the timer. This way the scheduler never gets called, and never has to check any flags.

The scheduler is generally disabled inside a critical section, where we do not want to OS to preempt the current thread. Otherwise, the scheduler should remain active.

Further reading

- "Design Patterns for Real-Time Systems: Resource Patterns" ^[1] by Bruce Powel Douglass 2002
- Microchip RTOS app notes ^[2] include "Microchip AN585: A Real-Time Operating System for PIC16/17", which describes writing your own RTOS.
- Greg Hawley ^[3] notes that "buying your RTOS, in most cases, is the better choice [than] ... building an RTOS from scratch"
- "The Perfect RTOS" ^[4] by Colin Walls 2004 [link not working]
- "Really simple memory management: Fat Pointers" ^[5] describes a simple garbage collection and memory defragmentation scheme that is compatible with small real-time systems (it never does a "stop the world").

- "FLIRTING with 8-bit MCU OSes" ^[6] by Dave Armour 2009 describes implementing just about the minimum functionality required for a pre-emptive OS: TaskCreate(), TaskDestroy(), and a very simple timer-driven task switcher. "FLIRT" uses 144 bytes of flash.

References

- [1] <http://www.awprofessional.com/articles/article.asp?p=30188&seqNum=3&rl=1>
- [2] http://microchip.com/stellent/idcplg?IdcService=SS_GET_PAGE&nodeId=1490&filterID=388
- [3] <http://www.embedded.com/1999/9903/9903sr.htm>
- [4] <http://www.techonline.com/learning/techpaper/embedded/37804>
- [5] <http://www.logarithmic.net/pfh/blog/01184061815>
- [6] <http://www.embedded.com/design/opensource/218600135?printable=true>

Embedded Systems/Locks and Critical Sections

This page of the Embedded Systems book is a stub. You can help by expanding this section.

An important part of an RTOS is the lock mechanisms, and the Critical Section (CS) implementation. This section will talk about some of the problems involved in creating these mechanisms.

Basic Critical Sections

Most embedded systems have at least one data structure that is written by one task and read by another task. With a preemptive scheduler, it is all too easy to write software that *seems* to work fine most of the time, but occasionally the writer will be interrupted right in the middle of updating the data structure, the RTOS switches to the reader task, and then the reader chokes on the inconsistent data.

We need some way of arranging things so that a writer's modification appears "atomic" -- a reader always sees only the (consistent) old version, or the (consistent) new version, never some partially-modified inconsistent state.

There are a variety of ways to avoid this problem, including:

- Design the data structure so that the writer can update it in such a way that it is always in a consistent state. This requires hardware that supports atomic primitives powerful enough to update the data structure from one consistent state to the next consistent state in one atomic operation. Wikipedia:lock-free and wait-free algorithms.
- Have the writer turn off the task scheduler while it is updating the data structure. Then the only time the reader could possibly see the data structure, the data structure is in a consistent state.
- Have the writer turn off all interrupts (including the timer interrupt that kicks off the task scheduler) while it is updating the data structure. Then the only time the reader could possibly see the data structure, the data structure is in a consistent state. But this makes interrupt latency much worse.
- Use a "lock" associated with each data structure. When the reader sees that the writer is updating the data structure, have the reader tell the task scheduler to run some other process until the writer is finished. (There are many kinds of locks).
- Use a "monitor" associated with every routine that uses a data structure.

Whenever a lock or CS mechanism is called, it is important that the RTOS disable the scheduler, to prevent the atomic operations from being preempted and executed incorrectly. Remember that embedded systems need to be stable and robust, so we cannot risk having the operating system itself being preempted while it is trying to create a lock or critical section. If we have a function called DisableScheduler(), we can call that function to disable the scheduler before any atomic operation is attempted, and we can then have a function called EnableScheduler() to restore the scheduler, and continue with normal operation.

Let us now create a general function for entering a critical section:

```

EnterCS()
{
    DisableScheduler();
    return;
}

```

and one for exiting a critical section:

```

ExitCS()
{
    EnableScheduler();
    return;
}

```

By disabling the scheduler during the critical section, we have guaranteed that no preemptive task-switching will occur during the critical section.

This method has a disadvantage that it slows down the system, and prevents other time-sensitive tasks from running. Next, we will show a method by which critical sections can be implemented to allow for preemption.

Critical Section Objects

Critical Sections, like any other term in computing can have a different definition than simply an operation that prevents preemption. For instance, many systems define a CS as being **an object that prevents multiple tasks from entering a given section of code**. Let us say that we are implementing a version of `malloc()` on our system. We want to ensure that once a memory allocation attempt has started, that no other memory allocation attempts can begin. Only 1 memory allocation attempt can be happening at one time. However, we want to allow for the `malloc` function to be preempted just like every other function. To implement this, we need a new data object called a `CRITICAL_SECTION`, or `CRIT_X`, or something of that nature. Our `malloc` function will now look like this:

```

CRIT_SECT mallocCS; //a global CS variable, for use in all tasks.

int RTOS_main(void) //we register our CS in the beginning of the RTOS main routine
{
    AllocCS(mallocCS); //register our critical section with the OS, to prevent duplicates
    ...

void *malloc(size_t size)
{
    void *ptr;
    EnterCS(mallocCS); //we enter the CS, and no other instance of malloc can enter it.
    ptr = FindFreeMemory(size);
    ExitCS(mallocCS); //other malloc attempts can now proceed
    return ptr;
}

```

If two tasks call `malloc` at nearly the same time, the first one will enter the critical section, while the second one will wait, or be "blocked" at the `EnterCS` routine. When the first `malloc` is finished, the second `malloc`'s `EnterCS` function will return, and the function will continue.

To allow other processes looking at other data structures to continue even though this data structure has been locked, `EnterCS()` is typically redefined something like:

```
// non-blocking attempt to enter critical section
int TryEnterCS( CRIT_SECT this )
{
    int success = 0;
    DisableScheduler();
    if( this->lock == 0 ){
        this->lock = 1; // mark structure as locked
        success = 1;
    };
    EnableScheduler();
    return success;
}

// blocking attempt to enter critical section
EnterCS( CRIT_SECT this ){
    int success = 0;
    do{
        success = TryEnterCS( this->lock );
        if( !success ){ Yield(); } // tell scheduler to run some other task for a while.
    }while( !success );
    return;
}

// release lock
ExitCS( CRIT_SECT this )
{
    ASSERT( 1 == this->lock );
    this->lock = 0;
    return;
}
```

The value to creating a Critical Section object, and using that to prevent preemption of sensitive areas is that this scheme does not slow down the system, the way the first scheme does (by disabling the scheduler, and preventing other tasks from executing).

Some OSes, such as Dragonfly BSD, implement EnterCS() and ExitCS() using "serializing tokens", in such a way that when a process attempts to get a lock on another data structure, the OS briefly releases all locks that process holds, before giving that process a lock on all requested locks.

Further Reading

- Barr, Michael. "Multitasking Alternatives and the Perils of Preemption," ^[1] Embedded Systems Design, January 2006.

References

- [1] <http://netrino.com/Articles/RTOSAlternatives/>

Embedded Systems/Common RTOS

This chapter will discuss some particular RTOS implementations. We may use some technical terms described in the [../Real-Time Operating Systems/](#) chapter.

Requested RTOS

Use this page to request or suggest a new chapter about a new RTOS.

Add new RTOS's here before adding them to the main page. **Do not** list an RTOS on the main page if you do not intend on writing a chapter for it yourself. There are far too many different RTOS's in this world to list every instance on the main table of contents, and expect other users to fill in the blanks. Many RTOS are designed for a particular purpose, and few are common enough that other contributors can be expected to have some experience with them.

- INTEGRITY
- veLOSity
- u-veLOSity
- QNX (Operating System Design/Case Studies/QNX)
- VxWorks
- eCos
- ST OS20
- FreeOSEK [1]
- DSPnano [2]
- Unison [3]
- Atomthreads [4]

Many embedded systems have no "operating system" other than a Forth or BASIC interpreter.

Common embedded operating systems

In this book, we discuss these operating systems commonly used in embedded systems:

- Palm OS
- Windows CE
- MS-DOS or DOS Clones
- Linux, including RTLinux and MontaVista Linux and Unison OS

For further reading

A variety of embedded systems and RTOS are based on Linux -- see [Embedded Systems/Linux](#) for details.

- [Embedded Control Systems Design/Operating systems](#)
 - [Wikipedia:INTEGRITY](#): A small, message passing, hard real-time micro kernel with memory protection designed for safety critical and high security devices.
 - [Wikipedia:Contiki](#): a small, open source, operating system developed for use on a number of smallish systems ranging from 8-bit computers to embedded microcontrollers.
 - [Wikipedia: eCos \(embedded Configurable operating system\)](#): an open source, royalty-free, real-time operating system intended for embedded systems and applications. ... eCos was designed for devices with memory footprints in the tens to hundreds of kilobytes, or with real-time requirements.
 - [Wikipedia:DSP/BIOS](#): a royalty-free real-time multi-tasking kernel (mini-operating-system) created by Texas Instruments.
-

- Wikipedia:QNX
- Wikipedia:VxWorks: A small footprint, scalable, high-performance RTOS
- Wikipedia:Windows CE
- Wikipedia:Palm OS
- "pico]OS" [5] has been ported to the Atmel AVR, the ARM, and the 80x86
- Wikipedia:OSEK is not an OS, but an open standard for automotive real-time operating systems.
- MaRTE OS - Minimal Real-Time Operating System for Embedded Applications ^[6] (*Is this related to Wikipedia: MARTE ?*)
- Wikipedia: TinyOS is an open-source operating system designed for wireless embedded sensor networks ("networked sensors").
- Wikipedia: ChibiOS/RT is an open-source real-time operating system that supports LPC214x, AT91SAM7X, STM32F103x and AVRmega processors.
- Wikipedia: Fusion RTOS is a license-free embedded operating system that supports ARM, Analog Devices Blackfin, Motorola StarCore and Motorola DSP 56800E.
- Wikipedia: FreeRTOS is an open-source embedded operating system kernel that supports ARM, Atmel AVR, AVR32, HCS12, MicroBlaze, MSP430, PIC18, dsPIC, Renesas H8/S, x86, 8052 processors. FreeRTOS can be configured for both preemptive or cooperative operation. FreeRTOS, SafeRTOS, and OpenRTOS are based on the same code base.
- Wikipedia: RTEMS (Real-Time Executive for Multiprocessor Systems) is a free open source real-time operating system (RTOS) designed for embedded systems.
- Wikipedia: MicroC/OS-II is an embedded RTOS intended for safety critical embedded systems such as aviation, medical systems and nuclear installations; it supports a wide variety of embedded processors.
- "The Real-time Operating system Nucleus" Wikipedia: TRON Project
- Wikipedia: DSPnano RTOS Ultra Tiny Embedded Linux and POSIX compatible RTOS for 8/16 Bit MCUs with Dual Licensing. Free open source versions and commercially supported versions for MCUs, DSCs and DSPs.
- Wikipedia: Unison RTOS Ultra Tiny Embedded Linux and POSIX compatible RTOS for 32 Bit MCUs with Dual Licensing. Free open source versions and commercially supported versions for MCUs, DSCs and DSPs.

References

- [1] <http://opensek.sf.net>
- [2] <http://rowebots.com/products/dspnano>
- [3] <http://rowebots.com/products/unison>
- [4] <http://atomthreads.com>
- [5] <http://picoos.sourceforge.net/>
- [6] <http://martie.unican.es>

Embedded Systems/Common RTOS/Palm OS

For many years, the Palm OS was the defacto RTOS used in hand-held devices, primarily the Palm handheld PDAs. However, Palm has lost a large amount of market share in recent years, and has lost dominance in the PDA market. However, many Palm devices still exist in this world, and an intrepid engineer can still find and use an old palm device as the primary microcontroller for other projects. This page will discuss Palm OS, and--to a lesser extent--Palm PDAs.

Further Reading

- PalmOS Guide
- <http://pluggedin.palm.com>
- "A Waba-Powered Palm Pilot Robot" ^[1] by James Caple 2001 discusses how to make your Java application run on a Palm Pilot and control a robot.
- RoboPilot ^[2] allows you to use the serial port on your Palm Pilot (Palm Pro or later model) to control a robot that uses the Lynxmotion Inc, Serial Servo Controller (SSC)
- The Palm Pilot Robot Kit (PPRK)
 - "Build your own Palm powered robot" ^[3] by Greg Reshko, Matt Mason, and Illah Nourbakhsh
 - "PPRK Overview" ^[4]
 - Carnegie Mellon University: Palm Pilot Robot Kit ^[5]
- Robot ASCII Serial Command Interpreter (RASCI) ^[6]

References

- [1] <http://java.sys-con.com/node/36769>
 - [2] <http://www.taygeta.com/robots/robopilot.html>
 - [3] <http://www.palmpower.com/issues/issue200012/robot001.html>
 - [4] <http://www.acroname.com/robotics/info/PPRK/overview.html>
 - [5] <http://www.cs.cmu.edu/~pprk/>
 - [6] <http://www.mrrobot.com/rasci.html>
-

Embedded Systems/Common RTOS/Windows CE

Windows CE has been gaining a large market share in the high-end PDA market, and can even be found occasionally on cell phones as well. Windows CE is very similar to other Windows implementations, and actually has a nearly complete implementation of the Win32 programming API for developers to tap into. This page will briefly discuss Windows CE, because further discussions of it are heavily related to discussions of the desktop breeds of Windows, and this book does not have enough scope to discuss windows architecture, the Windows API, or windows programming in general.

Currently, Windows CE implementations ship with the .NET Compact framework. This means that Windows CE applications can be programmed in traditional languages (C, C++, etc) but also .NET languages such as C# and VB.NET.

Further Reading

- Windows Programming

Embedded Systems/Common RTOS/DOS

DOS

Operating systems based off of MS-DOS still enjoy a huge market segment within the development community of embedded systems design. There are many reasons for this, most importantly is that MS-DOS can hardly even be called an operating system by many modern measurements. Almost all DOS-based software usually has exclusive control over the computer while it is running, and a major bonus is that the footprint for the operating system is usually very small. You can put a stripped down version of FreeDOS (a current MS-DOS clone that is still being updated) that fits in just 100K of hard drive space. Even less is required within the memory of the computer. You can even still purchase MS-DOS 6.22, but it must be from specialized software distributors who are under license from Microsoft, and it is no longer "supported" by Microsoft in terms of any software updates, even for known bugs.

Strengths and Weaknesses

The major advantage of DOS is also its largest drawback. By having so little actual operating in the computer, the software developer for DOS must perform many tasks traditionally thought of as something in the operating system. For instance, DOS doesn't have built-in capability for scheduling or multithreading. You must also install interrupt handlers directly into the software application, and API calls tend to be through software interrupts rather than some other more direct procedural method instead. Equipment vendors supporting DOS tend to follow an approach of either providing raw spec sheets for their equipment, or writing a pre-compiled binary object library that has to be linked into your software using a specific compiler.

Software Base

There is a huge software base for developing software in DOS, which is another major strength. Pre-written (even free) libraries for doing things like event scheduling and multi threading do exist for DOS, as well as GUI interface models and support libraries for most standard equipment peripherals. You can even find good compilers for DOS environments that compile to 32-bit protected mode as well, so you are not restricted to just the 8086 instruction set either.

Conclusion

DOS is a good base OS to build a custom RTOS that has specific features that you need without the extra cruft that you don't. It does require a little bit more time to put these extra features that you may need on a specific project, so it is more a trade off of time vs. money. If you have the time to make a well-crafted piece of software fit into a very small memory footprint, DOS as a RTOS is the way to go. It also allows a generally long shelf time for a project that once completed doesn't have to be changed as often to fit obsoleting chip technologies.

Further Reading

- A Neutral Look at Operating Systems/DOS
<http://www.freedos.org> The home of the FreeDOS project.
- <http://freedos-32.sourceforge.net/> home of the FreeDOS-32 project.
- <http://reactos.org/ReactOS> Development Wiki

Embedded Systems/Linux

A few of the many versions of Linux are designed for embedded systems.

Unlike the majority of "desktop" or "server" distributions of Linux, these versions of Linux either

- (a) support real-time tasks, or
- (b) run in a "small" embedded system, typically booting out of Flash, no hard drive, no full-size video display, and take far less than 2 minutes to boot up, or
- (c) both.

Linux and MMU

Linux was originally designed on a processor with a memory management unit (MMU). Most embedded systems do not have a MMU, as we discussed earlier (Embedded Systems/Memory).

Benefits of using a processor with a MMU:

- can isolate running "untrusted" machine code from running "critical" code, so the "untrusted" code is guaranteed (in the absence of hardware failures) not to interfere with the "critical" code
- makes it easier for the OS to present the illusion of virtual memory
- can run "normal" Linux (could also run "µClinux", but what's the point?)

Benefits of using a processor without a MMU:

- typically lower-cost and lower-power
 - can still run the "µClinux" version of Linux specifically designed to run on processors without a MMU.
-

Linux and real time

People use a variety of methods to combine real-time tasks with Linux:

- Run the real-time tasks on a dedicated microcontroller; communicate with a (non-real-time) PC that handles non-real-time tasks. This is pretty much your only choice if you need real-time response times below 1 microsecond.
- Run the real-time tasks in a "underlying" dedicated real-time operating system; run Linux as a "nested operating system" inside one low-priority task on top of the real-time operating system. Some of these systems claim real-time response times below 500 microseconds.
- use a Linux kernel designed to emphasize real-time tasks, and run the real-time tasks with a high priority (perhaps even as a kernel thread). As Linux develops, it seems to be getting better response times ("*Preemptible kernel patch makes it into Linux kernel v2.5.4-pre6*" ^[1]; *Linux kernel gains new real-time support* ^[2]).

Typically embedded Linux needs a minimum of about 2 MB of RAM, not including application and service needs[3].

further reading

- using Linux with hard real-time tasks:
 - the Real-Time Linux wiki ^[4]
 - Wikipedia:Xenomai
 - Wikipedia:RTLinux
 - Wikipedia:RTAI
 - Wikipedia:MontaVista Linux
 - "Real Time Linux Foundation" ^[5]
 - "Real-time Linux Software Quick Reference Guide" ^[6] describes many projects that try to bring real-time systems and Linux together.
- non-real-time Linux distributions designed for embedded systems:
 - Wikipedia: uClinux ("MicroController Linux") is a version of the Linux kernel that supports Altera NIOS, ADI Blackfin, ARM, ETRAX, Freescale M68K (including DragonBall, ColdFire, PowerQUICC and others), Fujitsu FRV, Hitachi H8, MIPS, and Xilinx MicroBlaze processors.
 - Wikipedia: Embeddable Linux Kernel Subset (ELKS) is a small subset of Linux that, like uClinux, can run even on machines that lack a MMU. It apparently only supports x86 machines (including the 8088-based original IBM PC, the 80286-based original IBM PC/AT, the NEC V30H-based Psion Series 3, etc.)
 - "Real Time and Embedded Guide ("rtHOWTO")" ^[7] by Herman Bruyninckx 2002 claims that standard Linux (in 2002) is not a true real-time OS nor an embedded OS.
 - The coreboot project (formerly known as the "LinuxBIOS" project) is developing firmware that replaces a standard "BIOS", boots out of motherboard Flash just like standard BIOS, and boots into almost any modern 32-bit operating system much faster than a standard BIOS (by cutting out most of the "device detection" and "hardware initialization" a standard BIOS does, since the OS needs to do that all over again anyway).
 - Wikipedia: coreboot
 - LinuxBIOS wiki ^[8]
 - "Stallman calls for action on Free BIOS" ^[9]
 - "Reducing OS Boot Times for In-Car Computer Applications" ^[10] by Damien Stolarz 2004
 - "Comparing real-time Linux alternatives" ^[11] by Kevin Dankwardt
 - LynuxWorks ^[12] sells a DO-178B certifiable RTOS and also BlueCat embedded Linux.
 - "hard real-time Linux technology" ^[13]
 - "modifications to the Linux kernel in order to provide a real-time operating system" ^[14]

- U-Boot (the Universal Bootloader) and Embedded Linux ^[15]
- RED-Linux (Real-time and Embedded Linux) ^[16]
- KURT-Linux: Kansas University Real-Time Linux ^[17]
- the Realtime Linux Security Module ^[18] "selectively grants realtime permissions to specific user groups or applications".
- "Real-Time Linux" ^[19] by Alex Ivchenko 2001 "for Linux to be a true alternative to traditional real-time operating systems, its lack of determinism must be dealt with. Real-time extensions have recently made this ... easy"
- "Linux: Realtime Approaches" ^[20] 2005
- "embeddedTUX.org" ^[21], the companion site to Karim Yaghmour's book *Building Embedded Linux Systems*
- The Linux Kernel

References

- [1] <http://www.linuxdevices.com/news/NS3989618385.html>
- [2] <http://www.linuxdevices.com/news/NS9566944929.html>
- [3] <http://en.wikipedia.org/wiki/ECos>
- [4] <http://rt.wiki.kernel.org/>
- [5] <http://realtimelinuxfoundation.org/>
- [6] <http://linuxdevices.com/articles/AT8073314981.html>
- [7] <http://people.mech.kuleuven.be/~bruyning/rthowto/>
- [8] <http://linuxbios.org/>
- [9] <http://www.fsf.org/news/freebios.html>
- [10] <http://www.linuxjournal.com/article/7857>
- [11] <http://www.linuxdevices.com/articles/AT4503827066.html>
- [12] <http://lynuxworks.com/>
- [13] <http://www.windriver.com/announces/rtlinux/>
- [14] <http://www.realtimelinuxfoundation.org/variants/variants.html>
- [15] <http://denx.de/wiki/>
- [16] <http://linux.ece.uci.edu/RED-Linux/>
- [17] <http://itc.ku.edu/kurt/>
- [18] <http://sourceforge.net/projects/realtime-lsm/>
- [19] <http://www.embedded.com/story/OEG20010418S0044>
- [20] <http://kerneltrap.org/node/5291>
- [21] <http://embeddettux.org/>

Interfacing

Embedded Systems/Interfacing Basics

Having our embedded system, with a fancy operating system is all well and good. However, embedded computers are worthless if they can't interface with the outside world. The chapters in this section will talk about some of the considerations involved with interfacing embedded systems.

Pins and Ports

Many embedded systems will provide a series of output pins for transmitting data to the outside world. These pins are arranged into groups called "ports". Ports will frequently (but not always) consist of a power-of-2 number of pins. For instance, common ports might be 4 pins, 8 pins, 16 pins, etc. It is rare to see ports with fewer than 4 pins (because in that case, they probably aren't called ports anymore).

Current and Power

When working with a particular microcontroller, it is very important to read the datasheet, to find out how much current different pins can handle. When talking about current, datasheets will (usually) mention 2 words: Sink and Source.

Sink

The sink value is the amount of current that can flow into the pin (and therefore into the microcontroller) safely.

Source

The source current is the amount of current that can be pulled out of the pin safely.

If you exceed the sink current or the source current on a given pin, you could fry the entire processor, which means added expense, and more time. It is very important that you try to limit the amount of current flowing into and out of your pin.

Ohms Law

Some people would like to never see Ohm's law again, and some people have never seen it before. Ohm's law relates the voltage and the current of a given circuit together, as such:

$$v = ir$$

Where v is the voltage, i is the current, and r is the resistance of the circuit. Let's do an example. We have a microcontroller with output pins that can source 20mA (mA = milliamps), and goes from 0V (for a logical "0") to +5V (for a logical "1"). Using Ohm's law:

$$+5V = (20mA)r \rightarrow r = 250\Omega$$

keep in mind that the resistance is the minimum value necessary to meet the requirements, we could easily pick a resistor with 300Ohms, or even 1KOhm if that was all we had. It is very important to note that diodes, transistors, and relay circuits (all of which are common in embedded systems) can be considered to have an effective resistance of 0. Therefore, it is very important to place resistors in a circuit to control the current flow.

further reading

- Analog and Digital Conversion
- Electronics/Digital to Analog & Analog to Digital Converters

Embedded Systems/External ICs

Integrated Circuits (IC) frequently have very similar operating characteristics to microcontrollers. It is often possible to connect different pins directly to each other without resistors to control the current flow, because the ICs will not draw much current.

Further Reading

- Digital Circuits
- Semiconductors

Embedded Systems/Low-Voltage Circuits

Low voltage circuits, in this field of consideration can essentially be considered circuits that never exceed the pin voltage (or exceed it by small amounts). If the voltage goes higher, or if we keep our current under control, we risk damage to our embedded systems.

Example: sensor

As a simple example we would like to measure the temperature.

The simplest and one of the cheapest ways to measure the temperature is to use a thermistor connected to GND, a resistor connected to VCC, and connect the other ends of each to the analog input pin of a microcontroller.

Because the thermistor and resistor are connected to the same power supply as the microcontroller, we can guarantee that the signal voltage is no higher than the VCC of the microcontroller, and no lower than GND. Because the analog input pin of a microcontroller inherently has high input resistance, we can guarantee that very little current flows. So in this case, we don't need any other components to protect the microcontroller from damage.

Example: Lighting LEDs

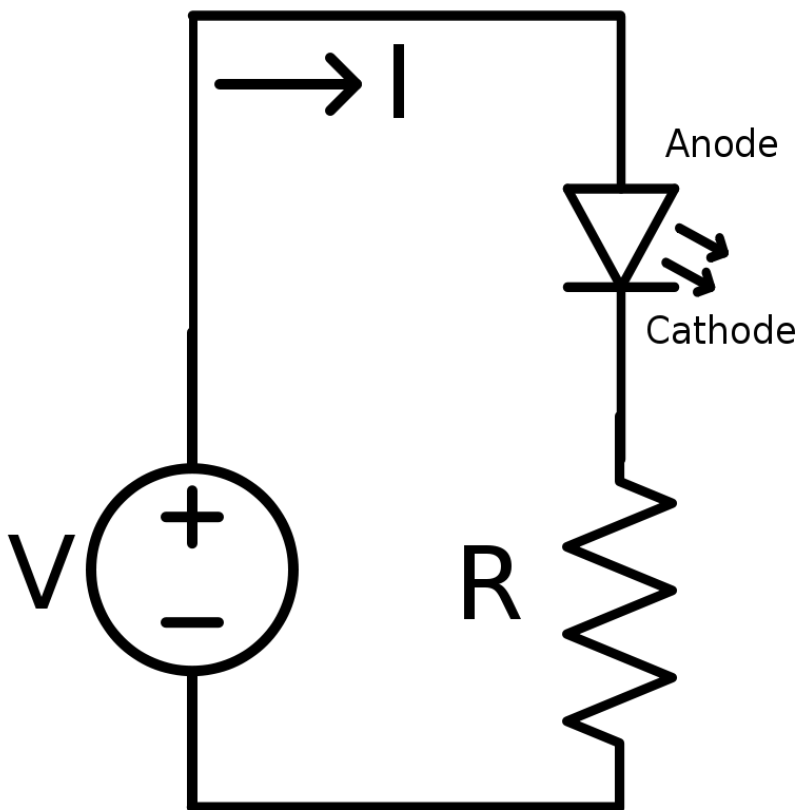

As a more complex example we would like to light a LED (light-emitting diode) from an output pin on an embedded computer. Consider that our output pin can source 20mA at +5V. Our LED is green, which implies a forward voltage drop of about 2 V. However, we also need to consider that our LED requires at least 10mA to light, and our LED can not exceed +20 mA. If the current through the LED gets too high, the LED could pop (it's an actual pop, cover your eyes).

Using ohm's law on the pin, we can find the minimum resistance for the circuit:

$$+5V - 2V = (20mA)r_{min} \rightarrow r = 150\Omega$$

Now, if we use Ohm's law on the diode, we can figure out the maximum resistance (the resistance that makes the LED not light up).

$$+5V - 2V = (10mA)r_{max} \rightarrow r = 300\Omega$$

So we know that our resistance, r , needs to be between 150 and 300 Ohms. Any less than that, and we can permanently destroy the LED or the microcontroller (or probably both). Any more than that, and no damage is done, but the LED will be too dim to see.

further reading

- Analog and Digital Conversion
- Wikipedia: ballast resistor

Embedded Systems/High-Voltage Circuits

Often we use embedded systems to control high-power devices. For example, maybe we want to program a microcontroller to turn on and off standard light bulbs.

As we discussed earlier, typical microcontroller output pins switch between 0 V and 5 V, and can drive a maximum of 0.025 A. But a typical light bulb requires 120 VAC at 0.5 A to turn on. We can't connect the microcontroller up to the 120 VAC directly. ^[1] What do we do?

Transistors and Relays

Some transistors, known as "Power Transistors", can control a high voltage source using a lower voltage control signal. There is also a type of electromechanical device known as a relay that can also be used to control a high voltage source with a relatively small control current. Both of these tools can be used to control the flow of a high-power electrical flow with an embedded computer.

Occasionally we need to use multiple stages of amplification. To turn on a large motor, we need a large relay -- but to turn on the large relay, we need a power transistor -- but to turn on the large transistor, we need at least a small transistor -- finally, we turn on the small transistor with the microcontroller output pin.

Isolation

When working with embedded systems, or any expensive piece of equipment, we often find that it is a good idea to isolate the expensive components from the high power components. We do this through a technique called **isolation**. Isolation, in essence, is how we keep the high current and/or high voltages out of low-current, low-voltage devices. There are several types of isolators.

The "isolation barrier" is an imaginary line between the high-current or high-voltage device on one side, and low-current, low-voltage devices on the other side.

- Transformers are used to transfer power from one side of the isolation barrier to the other
- optoisolators are used to transfer signals across an isolation barrier from one low-power device to another low-power device
- relays allow a microcontroller on one side of the isolation barrier to switch on and off high-power devices on the other side.

Transformers

Transformers use magnetic fields to move a voltage from one coil to another (over simplification). There is no direct wire connection between the input and the output terminals, and therefore transformers can help to prevent spikes on one side from damaging expensive equipment on the other.

Opto-Isolators

Opto-Isolators are the ultimate in isolation^[citation needed]. One half of the Opto-Isolator (OI) is an LED. The circuit connected to that side turns the light on and off. The other half of the optoisolator is a phototransistor. When the light is on, the phototransistor absorbs the light, and acts like a closed switch. When the light is off, the phototransistor acts like an open switch. Because light is used instead of electricity, and because the light can only go in one direction (from LED to phototransistor), they provide a very high level of reliable isolation.

The hardware MIDI interface is an example of a good opto-isolator interface.

Relays

Relays can also be used to isolate, because they act very similarly to transformers. The current flow in one wire is controlled by a magnetic field, generated by a second wire.

A relay controls whether electrons flow or not, by allowing a small current to the input coil producing a magnetic field in which operates the switch.

For further reading

- SCRs and triacs include several power transistors in a convenient package, and often cost less than buying equivalent transistors separately.
- [Wikipedia:relay](#)
- So-called "solid-state relays" ([Wikipedia:SSR](#)) are a convenient combination of an opto-isolator and some power transistors. Some SSRs include a [Wikipedia:Zero cross circuit](#).

References

- [1] (1) Occasionally someone does accidentally connect an integrated circuit to 120 V. The integrated circuit immediately self-destructs. If you're lucky, it cracks in half and lets off a small puff of smoke. If you're unlucky, it will still look like a good chip, leading to hours of frustration trying to figure out why the system isn't working.

Particular Microprocessor Families

Embedded Systems/Particular Microprocessors

This module of *Embedded Systems* is a very brief review of the most popular microprocessor families used in embedded systems. We will go into more detail in the next few modules. Each one of these microprocessor families has an entire module dedicated to that family of processors.

The microprocessor families we will discuss are:

- 8051 Microcontroller 8 bit
- Atmel AVR 8 bit
- Atmel AVR32
- Microchip PIC Microcontroller (this family includes the code-compatible Parallax SX chips) 8 bit
- Microchip dsPIC microcontroller 16 bit: review: Circuit Cellar: "Are You Up for 16 Bits? A look at Microchip's Family of 16-Bit Microcontrollers ^[1] by Jeff Bachiochi 2007; example application: μ Watch D-I-Y open source scientific calculator watch ^[2]
- Freescale Microcontrollers
- The Zilog Z8 Series (Z8, Z8encore, Z8XP)
- Cypress PSoC Microcontroller
- Texas Instruments MSP430 microcontrollers 16 bit
- ARM Microprocessors (this family includes the Philips LPC210x ARM microcontrollers, the discontinued Intel w:StrongARM, Atmel AT91RM9200, and the Intel XScale microprocessors)
- x86 microprocessors

brief selection guide

For many embedded systems, any of these microcontrollers would be more than adequate.

- TI MSP430 has the lowest power consumption. In sleep mode, $0.3 \mu\text{W} = 3 \text{ V} * 0.1 \mu\text{A}$. Some chips in 2xx and 4xx series include 12-bit DACs.
 - The Cypress PSoC has more than one true analog output. Using sleep mode, power consumption as low as $21 \mu\text{W} = 5 \text{ V} * 4.2 \mu\text{A}$ [3]. (You can get analog output from the other chips by using an external ADC, or by faking it with a PWM output and some low-pass filtering.) Most Cypress PSoC microcontrollers come in both DIP and SMT versions.
 - Many of these series include microcontrollers with integrated 10 bit ADCs, but Atmel AVR 8 bit series (as of early 2006) had the lowest-price chip that included such an ADC, as well as another chip with the lowest cost/ADC. Most Atmel AVR 8 bit microcontrollers come in both DIP and SMT versions.
 - If you need a very tiny chip, the Atmel AVR, PIC, and Freescale microcontroller lines all include tiny 8-pin SOIC microprocessors.
 - If you want a 32 bit processor, some Philips ARM processors and Freescale Coldfire processors are now under \$5 for one. (only comes in LQFP64 ?). The only (?) 32 bit processor currently being manufactured in a DIP package is the Parallax Propeller (w:Parallax Propeller) -- \$13 for one.
 - Many people and several commercial products run Linux on a XScale microprocessor or a Atmel AT91RM9200 (ARM core), without a heatsink or fan. Linux has also been ported to the Atmel AVR32 AP7 family [4] (only comes in a 208-pin VQFP). Linux has also been ported to Freescale 68k/ColdFire processors. I don't think Linux has been ported to any of the other processors mentioned above.
-

USB interface

Main page: Serial Programming:USB Technical Manual

(FIXME: very incomplete)

standard PC as host, microcontroller as device

There are a variety of ways to connect a microcontroller to a USB host.

- Some microcontrollers (such as some 18x series PICmicro, 24x94 series (x = 7, 8, 9) PSoC and some Philips ARM microcontrollers and some Atmel ARM microcontrollers and the Freescale MC9S08JS16) that have a built-in "Full Speed" USB device interface.
- practically all microcontrollers have a UART. You can add a USB adapter ^[5] that interfaces between that UART and USB, such as some based on the CP2102 chip ^[6] and some based on the FTDI chips ^[7]. Most of these adapters are designed to have the microcontroller at the device end, and a PC on the host end. These adapters are full speed (12Mbps) USB devices, but don't expect them to be fast, most of them emulate a serial port with baud rates up to about 1 Mbps.
- Many microcontrollers (such as the Atmel ATmega16) can be programmed to be a Low speed USB device with a few external passive components [8].

microcontroller as host, connecting to some USB device

There are a variety of ways to connect a microcontroller to a USB device.

- practically all microcontrollers have a UART, and some USB adapters[9] [10] can be set up with a microcontroller as the host, and some USB device (a mouse, keyboard, or flash drive) on the device end.
- a few microcontrollers (such as the Parallax Propeller) can be programmed to talk to a few USB peripherals with a few external passive components [11].

microcontroller as both a device (connected to a standard PC) and a host (connected to one or more USB devices)

How ? ... USB on-the-go (OTG) defines a single socket that automatically switches between host and device ... for example, a camera with a single USB socket that acts as a device when plugged into a PC (for uploading photos), but acts like a host when plugged into a printer (for printing photos directly without a PC) ... ^[12] ^[13]

- The LUFA library allows the USB-enabled AVR microcontrollers to act as a USB Host, slave or OTG device.[14]
- Most Atmel 32-bit AVR UC3 microcontrollers support full-speed (12 Mbps) USB 2.0 with USB Host, slave, or On-The-Go (OTG) capability

other details on USB

For more details on USB, see the Serial Programming:USB Technical Manual.

Further reading

- Instructables: "How to choose a MicroController" ^[15] by westfw
- Once you've picked out a processor, you'll want to know Embedded Systems/Where To Buy it.
- Robotics: Single Board Computers discusses "processor modules" that include the CPU and a few support chips in a convenient package.
- Getting started with microcontrollers ^[16], part of the "Microcontroller Primer FAQ" by Russ Hersch
- microcontrollers for wireless sensor network devices ^[17]

- "PIC vs. AVR" ^[18] "OK, I know what you people want. You want ultimate fighting, embedded E.E. style. You want to know WHICH IS BETTER, PIC OR AVR?"
- CNCzone: "Microchip vs Atmel" ^[19]
- PSoC Developer "PSoC VS PIC/AVR/ATMEL/8051" ^[20] has a brief comparison review of a few Freescale, Microchip, and Cypress CPUs.

References

- [1] <http://www.circuitcellar.com/archives/viewable/Bachiochi204/index.html>
- [2] <http://calcwatch.com/>
- [3] <http://www.psocdeveloper.com/forums/viewtopic.php?t=2953>
- [4] http://atmel.com/dyn/corporate/view_detail.asp?FileName=AT32AP7001_6_4.html
- [5] http://opencircuits.com/RS232_RS485_USB_Converter_Board
- [6] <http://www.dontronics-shop.com/product.php?productid=16141>
- [7] http://www.parallax.com/detail.asp?product_id=28024
- [8] http://sensorwiki.org/index.php/Building_a_USB_sensor_interface
- [9] <http://www.parallax.com/Store/Microcontrollers/BASICStampModules/tabid/134/txtSearch/604-00051/List/1/Default.aspx>
- [10] <http://www.parallax.com/Store/Microcontrollers/BASICStampModules/tabid/134/txtSearch/27937/List/1/Default.aspx>
- [11] <http://micah.navi.cx/2010/04/its-alive-bit-banging-full-speed-usb-host-for-the-propeller/>
- [12] "Understanding USB On-The-Go" (<http://www.edn.com/article/CA181883.html>) by Kosta Koeman 2001
- [13] "USB On-The-Go (OTG) Basics - AN1035" (<http://www.cypress.com/?rID=12904>)
- [14] <http://www.fourwalledcubicle.com/LUFA.php>
- [15] <http://www.instructables.com/id/How-to-choose-a-MicroController/>
- [16] <http://www.esacademy.com/automation/faq/primer/6.htm>
- [17] <http://wsn.oversigma.com/wiki/index.php/Microcontrollers>
- [18] <http://www.ladyada.net/library/picvsavr.html>
- [19] <http://www.cnczone.com/forums/showthread.php?p=266217>
- [20] <http://www.psocdeveloper.com/forums/viewtopic.php?f=3&t=3483>

Embedded Systems/Intel Microprocessors

When talking about Intel microprocessors, the first words that come to mind might be "Pentium" or "Celeron", or any of the other high-performance, expensive PC chips that are on the market today. However, Intel maintains a very impressive list of legacy parts that can be adapted for embedded systems. The beauty of using these microprocessors is that they are frequently very cheap, and they will all use the standard x86 assembly language, so that developers can program, assemble, and test from the comfort of a PC.

8086 and 80186

8086 and 80186 processors are available in heavily integrated packages. They are usually available in DIP form, and are relatively cheap (10\$ or 15\$ range). These processors might not be as good as an 8051 in an embedded environment, but the ease of programming, and the familiarity that many programmers will feel for these chips can more than make up for the cost.

i386 Embedded Processors

The i386 microprocessor is a modified form of the Intel 80386 microprocessor with a few notable differences: an integrated FPU (originally wasn't standard until the 80486), and a variety of different, small form-factors. One of the major benefits of an i386 microprocessor is that it can be programmed easily using most standard C compilers and x86 assembly language. In fact, many times no additional settings need to be changed in the compiler, except maybe to not link to the standard libraries on the host system.

i386 processors are 32 bit processors, and are frequently very economical choices when a 32bit processor is required. Also, i386 processors frequently have very low power consumption, and generate very little heat. Remember, Intel has been working on this architecture and the general design of this chip continuously for many years now.

X-Scale Embedded Processors

The X-Scale processor is an ARM based device, designed for embedded systems requiring high performance with low power consumption, such as PDA's.

Other Chips

Intel does sell embedded varieties of all its chips, from the 486 up to the Pentium 4. Keep in mind, however, that these chips have all the power of their PC cousins, but in a smaller package. Therefore, it can be expected that they will all be *considerably more expensive* than the desktop chips. Also, with some of the higher performance chips (pentium and up), since the size has been aggressively reduced, and because they have been highly integrated for embedded environments, heat can become an issue (meaning you will need to invest in fans and heat sinks as well).

Further reading

- ARM
 - x86 Assembly
-

Embedded Systems/PIC Microcontroller

Manufactured by Microchip, the PIC ("Programmable Intelligent Computer" or "Peripheral Interface Controller") microcontroller is popular among engineers and hobbyists alike. PIC microcontrollers come in a variety of "flavors", each with different components and capabilities.

Many types of electronic projects can be constructed easily with the PIC family of microprocessors, among them clocks, very simple video games, robots, servo controllers, and many more. The PIC is a very general purpose microcontroller that can come with many different options, for very reasonable prices.

Other microprocessors in this family include the Parallax SX, the Holtek HT48FxxE Series ^[1], and some "PIC-on-a-FPGA" implementations.

History

A long time ago General Instruments produced a chip called the PIC1650, described as a Programmable Intelligent Computer. This chip is the mother of all PIC chips, ~~functionally close to the current 16C54~~. It was intended as a peripheral for their CP1600 microprocessor. Maybe that is why most people think PIC stands for Peripheral Interface Controller. Microchip has never used PIC as an abbreviation, just as PIC. And recently Microchip has started calling its PICs microcontrollers PICmicro MCU's.

Which PIC to Use

How do you find a PIC that is right for you out of nearly 2000 different models of PIC microcontrollers?

Rule Number 1: only pick a microprocessor you can actually obtain. PICs are all similar, and therefore you don't need to be too picky about which model to use.

If there is only 1 kind of PIC available in your school storeroom, use it. If you order from a company such as Newark ^[2] or DigiKey ^[3], ignore any part that is "out of stock" -- only order parts that are "in stock". This will save you lots of time in creating your project.

Recommended "first PIC"

At one time, the PIC16F84 was far and away the best PIC for hobbyists. But Microchip, Parallax, and Holtek are now manufacturing many chips that are even better.

*I'd like a list of the top 4 or so PIC recommendations, and *why* they were recommended, so that when better/cheaper chips become available, it's easy to confirm and add them to the list.*

(Summarizing PICList Beginners checklist for PIC Microcontrollers ^[4], PIC Elmer 160: Appendix "A": "Other PICs" 2003 ^[5], and Wouter van Ooijen ^[6] :)

PIC: Select a chip and buy one ^[7].

Many people recommend the following PICs as a good choice for the "first PIC" for a hobbyist:

- PIC18F4620 -- has 13 analog inputs -- Wouter van Ooijen recommends that hobbyists use the largest and most capable chip available^[6], and this is it (as of 2006-01). ~\$9
- PIC16F877A -- the largest chip of the 16F87x family; has 8 analog inputs -- recommended by Wouter (#2); AmQRP; PICList. ~\$8
- PIC16F88 -- has 7 analog inputs -- recommended by AmQRP; SparkFun ^[8]. ~\$5
- PIC16F628 -- Cheaper than the PIC16F84A, with a built-in 4MHz clock and a UART, but lacks any analog inputs -- recommended by Wouter (#3); AmQRP -- ~\$4

Of the many new parts Microchip has introduced since 2003, are any of them significantly better for hobbyists in some way than these chips ?

There are several different "families":

More selection tips

- The "F" Suffix implies that the chip has reprogrammable Flash memory.

```
PIC10F -- in super-tiny 6 pin packages
PIC12F -- in tiny 8-pin packages
PIC14F
PIC16F
PIC18F
dsPIC30F
```

- ~~The "C" suffix implies that the chip uses EPROM memory. A few of these chips can be erased with an Ultra-Violet eraser. But most of these chips are specifically made so that once you write it you can't change it-- it's OTP (one-time programmable).~~

```
PIC12C
PIC16C
PIC17C
PIC18C
.
```

Each family has one "full" member with all the goodies and a subset of variant members that lack one thing or another. For prototyping, we generally use the "full" version to make sure we can get the prototype working *at all*. During prototyping we want to tweak code, reprogram, and test, over and over until it works. ~~So we use one of the above "Flash" families, not the "OTP" families.~~

Each member of each family generally comes in several different packages. Hobbyists generally use the plastic dual inline package (often called DIP or PDIP) because it's the easiest to stick in a solderless breadboard and tinker with. (The "wide-DIP" works just as well). They avoid using ceramic dual inline package (CDIP), not because ceramic is bad (it's just as easy to plug into a solderless breadboard), but because the plastic parts work just as well and are much cheaper.

(Later, for mass production, we may figure out which is the cheapest cut-down version that just barely has enough goodies to work, and comes in the cheapest package that has just barely enough pins for this particular application ... ~~perhaps even a OTP chip~~).

And then each different package, for each member of each family, comes in both a "commercial temperature range" and a "industrial temperature range".

PIC 16x

The PIC 16 family is considered to be a good, general purpose family of PICs. PIC 16s generally have 3 output ports to work with. Here are some models in this family that were once common:

1. ~~PIC 16C54 - The original PIC model, the 'C54 is available in an 18 pin DIP, with 12 I/O pins.~~
2. ~~PIC 16C55 - available in a 28-pin DIP package, with 20 available I/O pins.~~
3. ~~PIC 16C56 - Same form-factor as the 'C54, but more features.~~
4. ~~PIC 16C57 - same form-factor as the 'C55, but more features.~~
5. ~~PIC 16C71 - has 4 available ADC, which are mapped to the same pins as Port A (dual-use pins).~~
6. ~~PIC 16C84 - has the ability to erase and reprogram in-circuit EEPROMs.~~

Many programs written for the PIC16x family are available for free on the Internet.

Flash-based chips such as the PIC16F88 are far more convenient to develop on, and can run code written for the above chips with little or no changes.

PIC 12x

The PIC 12 series are all very small chips, with 8 pins, and 4 available I/O pins. These are used only when space is a huge factor, and the PIC doesn't have many responsibilities

PIC 18x

The PIC 18x series are available in a 28 and 40-pin DIP package. They have more ports, more ADC, etc... PIC 18s are generally considered to be very high-end microcontrollers, and are even sometimes called full-fledged CPUs.

Microchip is currently (as of 2007) producing 6 Flash microcontrollers with a USB interface. All are in the PIC18Fx family. (The 28 pin PIC18F2450, PIC18F2455, PIC18F2550; and the 40/44 pin PIC18F4450, PIC18F4455, PIC18F4550).

The PIC Stack

The PIC stack is a dedicated bank of registers (separate from programmer-accessible registers) that can only be used to store return addresses during a function call (or interrupt).

- 12 bit: A PIC microcontroller with a 12 bit core (the first generation of PIC microcontrollers) (including most PIC10, some PIC12, a few PIC16) only has 2 registers in its hardware stack. Subroutines in a 12-bit PIC program may only be nested 2 *deep*, before the stack overflows, and data is lost. People who program 12 bit PICs spend a lot of effort working around this limitation. (These people are forced to rely heavily on techniques that avoid using the hardware stack. For example, macros, state machines, and software stacks).
- 14 bit: A PIC microcontroller with a 14 bit core (most PIC16) has 8 registers in the hardware stack. This makes function calls much easier to use, even though people who program them should be aware of some remaining gotchas [9].
- 16 bit: A PIC microcontroller with a 16 bit core (all PIC18) has a "31-level deep" hardware stack depth. This is more than deep enough for most programs people write.

Many algorithms involving pushing data to, then later pulling data from, some sort of stack. People who program such algorithms on the PIC must use a separate software stack for data (reminiscent of Forth). (People who use other microprocessors often share a single stack for both subroutine return addresses and this "stack data").

Call-tree analysis can be used to find the deepest possible subroutine nesting used by a program. (Unless the program uses w:recursion). As long as the deepest possible nesting of the "main" program, plus the deepest possible nesting of the interrupt routines, give a total sum less than the size of the stack of the microcontroller it runs on, then everything works fine. Some compilers automatically do such call-tree analysis, and if the hardware stack is

insufficient, the compiler automatically switches over to using a "software stack". Assembly-language programmers are forced to do such analysis by hand.

What else do you need

Compilers, Assemblers

Versions of BASIC, C, Forth, and a few other programming languages are available for PICmicros. See Embedded Systems/PIC Programming.

downloaders

You need a device called a "downloader" to transfer compiled programs from your PC and burn them into the microcontroller. (Unfortunately "programming" has 2 meanings -- see Embedded_Systems/Terminology#programming.)

There are 2 styles of downloaders. If you have your PIC in your system and you want to change the software,

- with a "IC programmer" style device, you must pull out the PIC, plug it into the "IC programmer", reprogram, then put the PIC back in your system.
- with a "in circuit programmer" style device (ICSP), you don't touch the PIC itself -- you plug a cable from the programmer directly into a header that you have (hopefully) placed next to the PIC, reprogram, then unplug the cable.

An (incomplete) list of programmers includes:

- In Circuit Programmer for PIC16F84 PIC16F84 Programmer ^[10]
- IC Programmer ICProg ^[11] Programs : 12Cxx, 16Cxxx, 16Fxx, 16F87x, 18Fxxx, 16F7x, 24Cxx, 93Cxx, 90Sxxx, 59Cxx, 89Cx051, 89S53, 250x0, PIC, AVR , 80C51 etc.
- Many other programmers are listed at MassMind ^[12].

Many people prefer to use a "bootloader" for programming whenever possible. Bootloaders are covered in detail in chapter ../Bootloaders and Bootsectors/ .

Power Supply

The most important part of any electronic circuit is the power supply. The PIC programmer requires a +5 volt and a +13 volt regulated power supply. The need for two power supplies is due to the different programming algorithms:

- High Power Programming Mode - In this mode, we enter the programming mode of the PIC by driving the RB7(Data) and RB6(CLOCK) pins of the PIC low while driving the MCLR pin from 0 to VCC(+13v).
- Low Power Programming Mode - This algorithm requires only +5v for the programming operation. In this algorithm, we drive RB3(PGM) from VDD to GND to enter the programming mode and then set MCLR to VDD(+5v).

This is already taken care of inside the PIC burner hardware. If you are curious as to how this is done, you might want to look at the various PIC burner hardware schematics online. ^{[13] [14]}

Oscillator Circuits

The PIC microcontrollers all have built-in RC oscillator circuits available, although they are slow, and have high granularity. External oscillator circuits may be applied as well, up to a maximum frequency of 20MHz. PIC instructions require 4 clock cycles for each machine instruction cycle, and therefore can run at a maximum effective rate of 5MHz. However, certain PICs have a PLL (phase locked loop) multiplier built in. The user can enable the Times 4 multiplier, thus yielding a virtual oscillator frequency of 4 X External Oscillator. For example, with a maximum allowable oscillator of 16MHz, the virtual oscillator runs at 64MHz. Thus, the PIC will perform 64 / 4 =

16 MIPS (million instructions per second). Certain pics also have built-in oscillators, usually 4Mhz for precisely 1MIPS, or a low-power imprecise 48Khz. This frees up to two I/O pins for other purposes. The pins can also be used to produce a frequency if you want to synchronize other hardware to the same clock as one PIC's internal one.

programming

Continue with Embedded Systems/PIC Programming.

Further reading

There is a lot of information about using PIC microcontrollers (and electronics design in general) in the PICList archives. If you are really stumped, you might consider subscribing to the PICList, asking your question ... and answering someone else's question in return. The PICList archives are hosted at MassMind^[15]

- RC Airplane/RCAP discusses a project that uses a PIC16F876A.
- the Parallax SX FAQ^[16] by Guenther Daubach
- Microchip PIC^[17]: the original manufacturer's web site
- Getting Starting with PICmicro controllers^[6] by Wouter van Ooijen
- "The PIC 16F628A: Why the PIC 16F84 is now obsolete."^[18]
- "The PIC 16F88: Why the PIC 16F84 is now *Really* obsolete."^[19]
- "Free PIC resources and projects with descriptions, schematics and source code."^[20]
- "Programming PICmicros in the C programming language"^[21]
- "Programming PICmicros in other programming languages: Forth, JAL, BASIC, Python, etc."^[22]
- The "8-bit PIC® Microcontroller Solutions brochure"^[23] describes how big the PIC hardware stack is in each PIC microcontroller family, and other major differences between families.

[1] <http://holtek.com/>

[2] <http://www.newark.com>

[3] <http://digikey.com>

[4] <http://techref.massmind.org/techref/piclist/begin.htm>

[5] <http://amqrp.org/elmer160/lessons/index.html>

[6] http://www.voti.nl/swp/n_index.html

[7] <http://techref.massmind.org/techref/supplies.htm>

[8] <http://www.sparkfun.com/commerce/present.php?p=PIC%20Boot%20Loader>

[9] <http://massmind.org/techref/microchip/pages.htm>

[10] <http://www.ubasics.com/adam/pic/icp84.html>

[11] <http://www.ic-prog.com/>

[12] <http://massmind.org/techref/microchip/devprogs.htm>

[13] "PIC Microcontroller Programmers" (<http://massmind.org/techref/microchip/devprogs.htm>)

[14] "Choosing a PIC programmer" (<http://www.best-microcontroller-projects.com/pic-programmer.html>)

[15] <http://massmind.org/techref/microchip/>

[16] <http://forums.parallax.com/forums/default.aspx?f=7&m=73041>

[17] http://microchip.com/stellent/idcplg?IdcService=SS_GET_PAGE&nodeId=74

[18] <http://finitesite.com/d3jsys/16F628.html>

[19] <http://finitesite.com/d3jsys/16F88.html>

[20] <http://www.best-microcontroller-projects.com>

[21] <http://www.microchipe.com>

[22] <http://massmind.org/techref/microchip/languages.htm>

[23] <http://ww1.microchip.com/downloads/en/DeviceDoc/39630B.pdf>

- Micro&Robot - 877 (<http://www.scmstore.com/english/robotic/programmable/microrobot877.asp>): robot kit with self-programmable PIC Microcontroller! You don't need a PIC programmer.
- Programming the PIC16f628a with SDCC (<http://burningsmell.org/pic16f628/>): An occasionally-updated list of examples demonstrating how to use the PIC's peripherals and interface with other devices with the free SDCC

pic compiler.

Embedded Systems/8051 Microcontroller

The Intel 8051 microcontroller is one of the most popular general purpose microcontrollers in use today. The success of the Intel 8051 spawned a number of clones which are collectively referred to as the MCS-51 family of microcontrollers, which includes chips from vendors such as Atmel, Philips, Infineon, and Texas Instruments.

About the 8051

The Intel 8051 is an 8-bit microcontroller which means that most available operations are limited to 8 bits. There are 3 basic "sizes" of the 8051: Short, Standard, and Extended. The Short and Standard chips are often available in DIP form, but the Extended 8051 models often have a different form factor, and are not "drop-in compatible". All these things are called 8051 because they can all be programmed using 8051 assembly language, and they all share certain features (although the different models all have their own special features).

Some of the features that have made the 8051 popular are:

- 8-bit data bus
- 16-bit address bus
- 32 general purpose registers each of 8 bits
- 16 bit timers (usually 2, but may have more, or less).
- 3 internal and 2 external interrupts.
- Bit as well as byte addressable RAM area of 16 bytes.
- Four 8-bit ports, (short models have two 8-bit ports).
- 16-bit program counter and data pointer

8051 models may also have a number of special, model-specific features, such as UARTs, ADC, OpAmps, etc...

Typical applications

8051 chips are used in a wide variety of control systems, telecom applications, robotics as well as in the automotive industry. By some estimations, 8051 family chips make up over 50% of the embedded chip market.

Basic Pins

PIN 9: PIN 9 is the reset pin which is used reset the microcontroller's internal registers and ports upon starting up. 2 machine cycle should be high at this pin.

PINS 18 & 19: The 8051 has a built-in oscillator amplifier hence we need to only connect a crystal at these pins to provide clock pulses to the circuit.

PIN 40 and 20: Pins 40 and 20 are VCC and ground respectively. The 8051 chip needs +5V 500mA to function properly, although there are lower powered versions like the Atmel 2051 which is a scaled down version of the 8051 which runs on +3V.

PINS 29, 30 & 31: As described in the features of the 8051, this chip contains a built-in flash memory. In order to program this we need to supply a voltage of +12V at pin 31. If external memory is connected then PIN 31, also called EA/VPP, should be connected to ground to indicate the presence of external memory. PIN 30 is called ALE (address latch enable), which is used when multiple memory chips are connected to the controller and only one of them needs to be selected. We will deal with this in depth in the later chapters. PIN 29 is called PSEN. This is "program select enable". In order to use the external memory it is required to provide the low voltage (0) on both PSEN and EA pins.

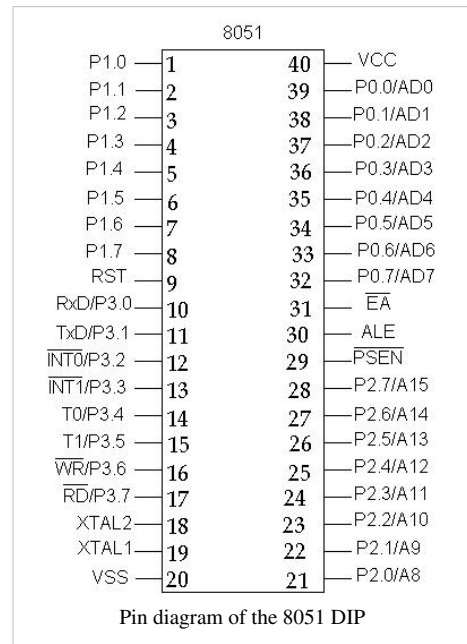

Ports

There are 4 8-bit ports: P0, P1, P2 and P3.

PORT P1 (Pins 1 to 8): The port P1 is a general purpose input/output port which can be used for a variety of interfacing tasks. The other ports P0, P2 and P3 have dual roles or additional functions associated with them based upon the context of their usage.

PORT P3 (Pins 10 to 17): PORT P3 acts as a normal IO port, but Port P3 has additional functions such as, serial transmit and receive pins, 2 external interrupt pins, 2 external counter inputs, read and write pins for memory access.

PORT P2 (pins 21 to 28): PORT P2 can also be used as a general purpose 8 bit port when no external memory is present, but if external memory access is required then PORT P2 will act as an address bus in conjunction with PORT P0 to access external memory. PORT P2 acts as A8-A15, as can be seen from fig 1.1

PORT P0 (pins 32 to 39) PORT P0 can be used as a general purpose 8 bit port when no external memory is present, but if external memory access is required then PORT P0 acts as a multiplexed address and data bus that can be used to access external memory in conjunction with PORT P2. P0 acts as AD0-AD7, as can be seen from fig 1.1

Oscillator Circuits

The 8051 requires the existence of an external oscillator circuit. The oscillator circuit usually runs around 12MHz, although the 8051 (depending on which specific model) is capable of running at a maximum of 40MHz. Each machine cycle in the 8051 is 12 clock cycles, giving an effective cycle rate at 1MHz (for a 12MHz clock) to 3.33MHz (for the maximum 40MHz clock).

Internal Architecture

[1] **Bold text**

Data and Program Memory

The 8051 Microprocessor can be programmed in PL/M, 8051 Assembly, C and a number of other high-level languages. Many compilers even have support for compiling C++ for an 8051.

Program memory in the 8051 is read-only, while the data memory is considered to be read/write accessible. When stored on EEPROM or Flash, the program memory can be rewritten when the microcontroller is in the special programmer circuit.

Program Start Address

The 8051 starts executing program instructions from address 0x00 in the program

Direct Memory

The 8051 has 256 bytes of internal addressable RAM, although only the first 128 bytes are available for general use by the programmer. The first 128 bytes of RAM (from 0x00 to 0x7F) are called the **Direct Memory**, and can be used to store data.

Special Function Register

The **Special Function Register** (SFR) is the upper area of addressable memory, from address 0x80 to 0xFF. This area of memory cannot be used for data or program storage, but is instead a series of memory-mapped ports and registers. All port input and output can therefore be performed by memory **mov** operations on specified addresses in the SFR. Also, different status registers are mapped into the SFR, for use in checking the status of the 8051, and changing some operational parameters of the 8051.

General Purpose Registers

The 8051 has 4 selectable banks of 8 addressable 8-bit registers, R0 to R7. This means that there are essentially 32 available general purpose registers, although only 8 (one bank) can be directly accessed at a time. To access the other banks, we need to change the current bank number in the flag status register.

A and B Registers

The A register is located in the SFR

memory location 0xE0. The A register works in a similar fashion to the AX register of x86 processors. The A register is called the **accumulator**,

and by default it receives the result of all arithmetic operations. The B register is used in a similar manner, except that it can receive the extended answers from the multiply and divide operations. When not being used for

multiplication and Division, the B register is available as an extra general-purpose register.

References

[1] <http://www.embedds.com/wp-content/uploads/2007i/0710/8051.jpg>

Embedded Systems/Freescale Microcontrollers

Freescale Semiconductor (formally Motorola Semiconductor Products Sector) spun-off from Motorola in July 2004. Freescale makes many microcontrollers (MCU's) and also a whole host of other devices such as sensors, DSP's and memory, to name a few.

The Freescale Microcontrollers come in 5 families.

- 6800 descendents: 8 bit or 16 bit
- 68000 descendents: 32 bit
- MCore: 32 bit
- PowerPC family: 32 bit
- ARM family: 32 bit. We discuss ARM core Freescale microcontrollers in another chapter, Embedded Systems/ARM Microprocessors.

8-bit MCUs

Freescale HC08

There are many variations on the HC08 CPU core; The 68HC908JL8 is one example. the HC908J13 offer 256 bytes of RAM (random access memory) and 4K bytes of Flash ROM (Read only memory). The Hc08 cores offer a maximum bus speed of 8MHz, a 20MHz crystal may be used as the external clock source(as the oscillator is internally divided by 4 to give 8MHz bus speed). Typical peripheral components of the microcontroller include:

- Two 16 bit, free running timers.
- SCI (serial communications interface,(RS232))
- 12 channel 8-bit Analogue to digital converters (A/D)

The HC08 microcontrollers are usually supplied in 28 pin or 32 pin DIL packages, but can also be obtained in surface-mount SOIC footprints

16-bit MCUs

32-bit Embedded Processors

68k/ColdFire

The 68k family and the nearly-binary-compatible ColdFire family are 32 bit processors capable of running Linux.

There is a Debian Linux port to 68k processors with a MMU. A Debian Linux port to ColdFire processors with a MMU is "in progress".

There are several ColdFire chips that, as of 2008, are available for under \$5 (in qty 1). Those low-cost chips do not include a MMU, and so cannot run a full version of Linux. w:uClinux runs on chips without a MMU, and has been ported to some ColdFire chips[1] on platforms with at least 1 MB of RAM.

Yes, but does uClinux actually run on a chip that costs less than \$5 ?

Most (all?) currently manufactured ColdFire and 68k chips are available only in surface mount packages, not in any DIP package.

PowerPC

- First Generation: G1 (601)
- Second Generation: G2 (603, 603e, 604)
- Third Generation: G3 (750, 750CX, 750CX3, 750FX, 750GX)
- Fourth Generation: G4 (7400,7450)

further reading

- w:Freescale 68HC12
- w:Freescale ColdFire
- w:PowerPC
- The 68HC12 discussion forum at EmbeddedRelated ^[2] is still pretty active, apparently because 68HC12 dev boards (such as those from EVBplus ^[3]) are typically lower-cost than dev boards with most other microcontrollers.
- EE Compendium: resources for using Freescale's HC12 family ^[4]
- w:Motorola 68000 family

References

- [1] <http://www.uclinux.org/ports/coldfire/>
- [2] <http://www.embeddedrelated.com/groups/68hc12/1.php>
- [3] <http://evbplus.com/>
- [4] <http://ee.cleversoul.com/hc12.html>

Embedded Systems/Atmel AVR

The **Atmel AVRTM** is a family of 8-bit RISC microcontrollers produced by Atmel. The AVR architecture was conceived by two students at the **Norwegian Institute of Technology (NTH)** and further refined and developed at **Atmel Norway**, the Atmel daughter company founded by the two chip architects.

Memory

The memory of the Atmel AVR processors is a Modified Harvard architecture, in which the program and data memory are on separate buses to allow faster access and increased capacity. The AVR uses internal memory for data and program storage, and so does not require any external memory.

The four types of memories in a Atmel AVR are:

- Data memory: registers, I/O registers, and SRAM
- Program flash memory
- EEPROM
- Fuse bits

All these memories are on the same chip as the CPU core. Each kind of memory is separated from each other, in different locations on the chip. Address 0 in data memory is distinct from address 0 in program flash and address 0 in EEPROM.

Program Memory

All AVR microcontrollers have some amount of 16 bit wide non-volatile flash memory for program storage, from 1KB up to 256KB (or, 512-128K typical program words). The program memory holds the executable program opcodes and static data tables. Program memory is linearly addressed, and so mechanisms like page banking or segment registers are not required to call any function, regardless of its location in program memory.

AVRs cannot use external program memory; the flash memory on the chip is the only program memory available to the AVR core.

The flash program memory can be reprogrammed using a programming tool, the most popular being those that program the chip *in situ* and are called in-system programmers (ISP). Atmel AVRs can also be reprogrammed with a high-voltage parallel or serial programmer, and via JTAG (again, *in situ*) on certain chips. The flash memory in an AVR can be re-programmed at least 10,000 times.

Many of the newer AVRs (MegaAVR series) have the capability to self-program the flash memory. This functionality is used mainly by bootloaders.

Data Memory

Data Memory includes the registers, the I/O registers, and internal SRAM.

The AVR has thirty-two general purpose eight-bit registers (R0 to R31), six of which can be used in pairs as sixteen-bit pointers (X, Y, and Z).

All AVR microcontrollers have some amount of RAM, from 32 bytes up to several KB. This memory is byte addressable. The register file (both general and special purpose) is mapped into the first addresses and thus accessible also as RAM. Some of the tiniest AVR microcontrollers have only the register file as their RAM.

The data address space consists of the register file, I/O registers, and SRAM. The working registers are mapped in as the first thirty-two memory spaces (0000_{16} - $001F_{16}$) followed by the reserved space for up to 64 I/O registers (0020_{16} - $005F_{16}$). The actual usable SRAM starts after both these sections (address 0060_{16}). (Note that the I/O register space may be larger on some more extensive devices, in which case the beginning address of SRAM will be

higher.) Even though there are separate addressing schemes and optimized opcodes for register file and I/O register access, they can still be addressed and manipulated as if they were SRAM.

The I/O registers (and the program counter) are reset to their default starting values when a reset occurs. The registers and the rest of SRAM have initial random values, so typically one of the first things a program does is clear them to all zeros or load them with some other initial value.

The registers, I/O registers, and SRAM never wear out, no matter how many times they are written.

External Data Memory

Some of the higher pin-count AVR microcontrollers allow for external expansion of the data space, addressable up to 64KB. When enabled, external SRAM is overlaid by internal SRAM; an access to address 0000_{16} in the data space will always resolve to on-chip memory. Depending on the amount of on-chip SRAM present in the particular AVR, anywhere from 512 bytes to several KB of external RAM will not be accessible. This usually does not cause a problem.

The support circuitry required is described in the datasheet for any device that supports external data memory, such as the Mega 162^[1], in the "External Memory Interface" section. The support circuitry is minimal, consisting of a '573 or similar latch, and potentially some chip select logic. The SRAM chip select may be tied to a logic level that permanently enables the chip, or it may be driven by a pin from the AVR. For an SRAM of 32KB or less, one option is to use a higher-order address line to drive the chip select line to the SRAM.

EEPROM Storage

Almost all AVR microcontrollers have internal EEPROM memory for non-volatile data storage. Only the Tiny11 and Tiny28 have no EEPROM.

EEPROM memory is not directly mapped in either the program or data space, but is instead accessed indirectly as a peripheral, using I/O registers. Many compilers available for the AVR hide some or all of the details of accessing EEPROM. IAR's C compiler for the AVR recognizes the compiler-specific keyword `__eeprom` on a variable declaration. Thereafter, a person writes code to read and write that variable with the same standard C syntax as normal variables (in RAM), but the compiler generates code to access the EEPROM instead of regular data memory.

Atmel's datasheets indicate that the EEPROM can be re-written a minimum of 100,000 times. An application must implement a wear-leveling scheme if it writes to the EEPROM so frequently that it will reach the write limit before it reaches the expected lifetime of the device. AVRs ship from the factory with the EEPROM erased, i.e. the value in each byte of EEPROM is FF_{16} .

Many of the AVRs have errata about writing to EEPROM address 0 under certain power conditions (usually during brownout), and so Atmel recommends that programs not use that address in the EEPROM.

Fuse Settings

A Fuse is an EEPROM bit that controls low level features and pin assignments. Fuses are not accessible by the program; they can only be changed by a chip programmer. Fuses control features which must be set before the chip can come out of reset and begin executing code.

The most frequently modified fuses include:

1. Oscillator/crystal characteristics, including drive strength and start-up time.
2. JTAG pins used for JTAG or GPIO
3. RESET pin used as a reset input, debugWire, or GPIO
4. Brown Out Detect (BOD) enable and BOD voltage trigger points

There is also a fuse to enable serial in-system programming, which is set by default. If it is set incorrectly, the only way to program the chip is by using a high-voltage programmer, such as the STK-500, AVR Dragon, or third-party

programmer. A developer is therefore cautioned to be careful when manipulating fuses.

Reset

The AVR's RESET pin is an active-low input that forces a reset of the processor and its integrated peripherals. The line can be driven by an external power-on reset generator, a voltage supervisor (which asserts RESET when the power supply voltage drops below a predefined threshold), or another component in a larger system. For example, if the AVR is managing a few sensors and servos as part of a large integrated system, another controller might observe some condition that justifies resetting the AVR; it could do so by asserting the AVR's RESET line.

AVRs also include a watchdog timer, which can reset the processor when it times out. The watchdog timer must be reset periodically to prevent it from timing out. Failure to reset the watchdog timer is usually an indication that the program code has failed (locked up, entered an infinite loop, or otherwise gone astray), and the processor should be reset. On some AVRs the watchdog can be programmed to issue an interrupt instead of resetting the processor. This functionality can be used to wake up the AVR from a sleep mode.

The RESET pin is used for in-system serial programming, as a GPIO, or for debugWIRETM low pin count debugging, depending on the chip and the programming of the fuse bits. If the reset functionality of that pin is disabled, it cannot be recovered by in-system serial programming, and another method such as high-voltage programming must be used.

Interrupts

AVRs support multiple interrupt sources, both internal and external. An interrupt could be from an internal peripheral reaching a certain state (i.e. character received on UART), or from an external event like a certain level on a pin. Each interrupt source causes a jump to a specific location in memory. That location is expected to contain either a RETI (Return from Interrupt) instruction to essentially ignore the interrupt, or a jump to the actual interrupt handler.

Most AVRs have at least one dedicated external interrupt pin (INT0). Older AVRs can trigger an interrupt on a high or low level, or on a falling edge. Newer AVRs add more options, such as triggering on the rising edge or either edge. Additionally, many of the newer AVRs implement pin-change interrupts for all pins in groups of eight, eliminating the need for polling the pins. The pin-change interrupt handler must examine the state of the pins that are associated with that interrupt vector, and determine what action to take.

Due to button bounce issues, it is considered poor design to connect a push button or other user input directly to an interrupt pin; some debouncing or other signal conditioning must be interposed so that the signal from the button does not violate the setup and hold times required on the interrupt pins.

General Purpose I/O Ports

General Purpose I/O, or GPIO, pins are the digital I/O for the AVR family. These pins are true push-pull outputs. The AVR can drive a high or low level, or configure the pin as an input with or without a pull-up. GPIOs are grouped into "ports" of up to 8 pins, though some AVRs do not have enough pins to provide all 8 pins in a particular port, e.g. the Mega48/88/168 does not have a PortC7 pin. Control registers are provided for setting the data direction, output value (or pull-up enabled), and for reading the value on the pin itself. An individual pin can be accessed using bitwise manipulation instructions.

Each port has 3 control registers associated with it, DDRx, PORTx, and PINx. Each bit in those registers controls one GPIO pin, i.e. bit 0 in DDRA controls the data direction for PortA0 (often abbreviated PA0), and bit 0 in PORTA will control the data (or pullup) for PA0.

The DDR (Data Direction Register) controls whether the pin is an input or an output. When the pin is configured as an output, the corresponding bit in the PORT register will control the drive level to the pin, high or low. When the pin is configured as an input, the bit in the PORT register controls whether a pull-up is enabled or disabled on that pin. The PIN (Port Input) register was read-only on earlier AVRs, and was used to read the value on the port pin, regardless of the data direction. Newer AVRs allow a write to the PIN register to toggle the corresponding PORT bit, which saves a few processor cycles when bit-banging an interface.

Timer/Counters

All AVRs have at least one 8-bit timer/counter. For brevity, a timer/counter is usually referred to as simply a timer.

Some of the Tiny series have only one 8-bit timer. At the high end of the Mega series, there are chips with as many as six timers (two 8-bit and four 16-bit).

A timer can be clocked directly by the system clock, by a divided-down system clock, or by an external input (rising or falling edge). Some AVRs also include an option to use an external crystal, asynchronous to the system clock, which can be used for maintaining a real-time clock with a 32.768KHz crystal.

The basic operation of a timer is to count up to FF_8 (or $FFFF_{16}$), roll over to zero, and set an overflow bit, which may cause an interrupt if enabled. The interrupt routine reloads the timer with the desired value in addition to any other processing required.

The value of a timer can be read back at any time, even while it is running. (There is a specific sequence documented in the datasheets to read back a 16-bit timer so that a consistent result is returned, since the AVR can only move 8 bits at a time.) A timer can be halted temporarily by changing its clock input to "disabled," then resumed by re-selecting the previous clock input.

PWM

Many of the AVRs include a compare register for at least one of the timers. The compare register can be used to trigger an interrupt and/or toggle an output pin (i.e. OC1A for Timer 1) when the timer value matches the value in the compare register. This may be done separately from the overflow interrupt, enabling the use of pulse-width modulation (PWM).

Some AVRs also include options for phase-correct PWM, or phase- and frequency-correct PWM.

The Clear Timer on Compare (CTC) mode allows for the timer to be cleared when it matches a value in the compare register, before the timer overflows. Clearing the timer prior to overflow manipulates the timer resolution, allowing for greater control of the output frequency of a compare match. It can also simplify the counting of an external event.

The ATtiny26 is unique in its inclusion of a 64MHz high-speed PWM mode. The 64MHz clock is generated from a PLL, and is independent of, and asynchronous to, the processor clock.

Some AVRs also include complementary outputs suitable for controlling some motors. A dead-time generator (DTG) inserts a delay between one signal falling and the other signal rising so that both signals are never high at the same time. The high-end AT90PWM series allows the dead time to be programmed as a number of system clock cycles, while other AVRs with this feature simply use 1 clock cycle for the dead time.

Output Compare Modulator

An Output Compare Modulator (OCM), which allows generating a signal that is modulated with a carrier frequency. OCM requires two timers, one for the carrier frequency, and the second for the signal to be modulated. OCM is available on some of the Mega series.

Serial Communication

AVR microcontrollers are in general capable of supporting a plethora of serial communication protocols and serial bus standards. The exact types of serial communication support varies between the different members of the AVR microcontroller family.

On top of support in hardware there is also often the option to implement a particular serial communication mechanism entirely in software. Typically this is used in case a particular AVR controller does not support some serial communication mechanism in hardware, the particular hardware is already in use (e.g. when two RS232 interfaces are needed, but only one is supported in hardware), or the chip's hardware can't be used, because it shares pins with other chip functions, and such a function is already in used for the particular hardware. The latter often happens with the low-pincount AVRs in DIP packages.

Finally, there is also the possibility to use additional logic to implement a serial communication function. For example, most AVRs don't support the USB bus (some later ones do so, however). When using an AVR which doesn't support USB directly, a circuit designer can add USB functionality with a fixed-function chip such as the FTDI232 USB to RS232 converter chip, or a general-purpose USB interface such as the PDIUSB11. Adding additional electronics is in fact necessary for some supported communication protocols, e.g. standard-compliant RS232 communication requires adding voltage level converters like the MAX232.

The number of serial communication possibilities supported by a particular AVR can be confusing at times, in particular if the pins are shared with other chip functions. An intensive study of the particular AVR's datasheet is highly recommended. The serial communication features most commonly to be found on AVRs are discussed in the following sections.

Universal Synchronous Asynchronous Receiver Transmitter (USART)

Recent AVRs typically come with a Universal Synchronous Asynchronous Receiver Transmitter (USART) built-in. A USART is a programmable piece of hardware which is capable of generating and decoding various serial communication protocols. USART is an acronym from the following words:

Universal

Can be used in a lot of different serial communication scenarios

Synchronous

Can be used for synchronous serial communication (sender and receiver are synchronised by a particular clock signal)

Asynchronous

Can be used for asynchronous serial communication (sender and receiver are not explicitly synchronised via a clock signal, but synchronise on the data signal).

Receiver

The hardware in the AVR can receive serial data

Transmitter

The hardware can send serial data

Earlier AVRs had a UART that did not support synchronous serial communication, hence the absence of the "S" in the acronym.

USARTs or UARTs work with logic voltage levels while e.g. the RS232 protocol requires much different voltage levels than the 5V or 3.3V supplies found on AVR circuits. The conversion from and to such voltage levels is performed by an additional chip which is commonly called a line driver or line interface.

With the right line interface an AVR's USART can, for example, be used to communicate with RS-232, RS-485, MIDI, LIN bus, or CANbus devices, to name some of the popular protocols.

See Robotics: Computer Control: The Interface: Networks for more details.

RS-232 Signalling

The RS-232 specification calls for a negative voltage to represent a "1" bit, and a positive voltage to represent a "0" bit. The spec allows for levels from +3 to +15V, and -3 to -15V, but +/-12V is commonly seen. The AVR does not have the ability to drive a negative output voltage on any GPIO pin, and so a level converter, such as the MAX232, is used to talk to PCs and strict RS-232 devices. See Serial Programming:RS-232 Connections for more detail on RS-232 wiring.

RS-232 has a relatively short maximum cable length. For longer cabling distances, consider using RS-485 signaling on your USART.

Two Wire Interface

TWI is a variant of Phillips' I²C bus interface. I²C consists of two wires, known as SDA (serial data) and SCL (serial clock), which use open-drain drivers and therefore require pull-ups to a logic-1 state. I²C uses a common ground, so all devices on the bus should be at the same ground potential to avoid ground loops. TWI uses 7 bit addressing, which allows for multiple devices to connect to the bus.

Many TWI devices have at least the top four bits of the address hard-coded, and the remaining bits configurable by some means such as connecting dedicated address pins to power or ground; this often allows for only 2-8 model X devices on the bus. The AVR's TWI hardware can act as Master or Slave, and can meet the 400Kbit/s spec.

Serial Peripheral Interface (SPI)

SPI, the Serial Peripheral Interface Bus, is a master-slave synchronous serial protocol. This means that there is a clock line which determines where the pulses are to be sampled, and that one of the parties is always in charge of initiating communication. It uses at least three lines, which are called:

MISO

Master In Slave Out.

MOSI

Master Out Slave In.

SCK

Serial Clock.

Conceptually, SPI is a bidirectional shift register; as bits are shifted out on either MISO or MOSI, bits are shifted in on the other line. The master always controls the clock.

An SPI slave has a Slave Select (SS) signal, which signals to the slave that it should respond to messages from the master. SS is almost always active-low. If there is only one master and one slave, the slave's SS line could be tied low, and the master would not need to drive it. If there are two or more slaves, then the master must use a separate slave select signal to each slave. The downside of this approach is that the master can only address as many slaves as it has extra outputs (without the use of a separate decoder).

Hardware Implementation The larger AVR microcontrollers have built-in SPI transceivers (from the ATMEGA8 upwards). The serial clock is derived from the processor clock, with several divisors available. The data length is always 8 bits. The clock polarity and phase may be configured, leading to four possible combinations of when the data is clocked in and out of the chip. This interface is very popular, and is widely available on a variety of other processors and peripherals.

The pins used for the SPI bus are also used as a way of programming the chip via ISP (In System Programming)(Except on the mega128).

Universal Serial Interface Some AVRs, particularly in the Tiny family, provide a Universal Serial Interface (USI) instead of an SPI. The USI is capable of operating as an SPI, but also as an I2C controller, and with a little extra effort, a USART. The bit length of the transfer is configurable, as is the clock driver. The clock can be driven by software, by the timer 0 overflow, or by an external source.

Software Implementation SPI can be implemented using bit-banging of the I/O lines. An efficient implementation of a slave can be done by connecting SCLK to an external interrupt source.

The datasheet for a particular AVR provides a block diagram of the SPI or USI controller on that chip.

Protocol Issues

SPI, RS-232, I²C, and other serial interfaces only define the method by which bits and bytes are transmitted; they correspond to layer 1 in the OSI model, the physical layer. The bytes could be anything: temperature readings (in Centigrade or Fahrenheit, depending on your sensor), readings from a pressure sensor, control signals to turn off a pump, or the bytes of a JPEG image. Some of this meaning may be assigned by the use of a serial communications protocol.

A serial protocol must handle a wide variety of usage conditions, as well as provide for recovering from failures. For example, if two sensors are connected to a single microcontroller (such as inside and outside temperature), the protocol provides a way for the receiver on the other end of the serial line to discern which reading belongs to which sensor. If a cable is unplugged during transmission, or a byte is lost due to line noise, the protocol can provide a way to re-synchronize the transmitter and the receiver.

The Serial Programming wikibook contains more discussion of serial protocols.

Analog Interfaces

Analog to Digital

Analog to digital conversion uses digital number to represent the proportion of the analog signal sampled. For example, by applying a 3V to the input of an ADC with a full-scale range of 5 V, will result as a digital output of 60% of the full range of the digital output. The digital number can be represented in 8 or 10 bits by the ADC. An 8 bit converter will provide output from 0 to $2^8 - 1$, or 255. 10 bits will provide output from 0 to $2^{10} - 1 = 1023$.

$$10 \text{ bit sample: } \frac{3V}{5V} = 0.6 \times 1023 = 614 \text{ in ADCH:ADCL or}$$

$$8 \text{ bit sample: } \frac{3V}{5V} = 0.6 \times 255 = 153 \text{ in ADCL}$$

Many AVRs include an ADC, specifically a successive-approximation ADC. The ADC reference voltage (5V in the example above) can be an external voltage, an internal fixed 1.1V reference.

AVRs with an ADC have several analog inputs which are connected to the ADC via an analog multiplexer. Only one analog input can be converted at any given time. The ADC controller provides a method for sequentially converting the inputs, so that an AVR can easily cycle through multiple sources thousands of times a second. AVRs can run

ADC conversions continuously in the background, or use a special "ADC sleep" mode to halt the processor while a conversion is taking place, to minimize voltage disturbances from the rest of the MCU.

Analog Comparator Peripheral

Nearly all AVR microcontrollers feature an Analog Comparator which can be used to implement an ADC on those AVRs which do not have an ADC, or if all of the ADC inputs are already in use. Atmel provides sample code and documentation for using the comparator as a low-speed ADC. The signal to be measured is connected to the inverted input, and a reference signal is connected to the non-inverting input. The AVR generates an interrupt when the signal falls below or rises above the reference value.

A common use for the analog comparator is sensing battery voltage, to alert the user to a low battery.

Other Integrated Hardware

Aside from what might be considered typical peripherals for a microcontroller (UART, SPI, ADC), some AVRs include more specialized peripherals for specific applications.

LCD Driver

In larger models like the ATmega169 (as seen in the AVR Butterfly), an LCD driver is integrated. The LCD driver commandeers several ports of the AVR to drive the column/row connections of a display. One particular trait of Liquid Crystal that must be taken care of is that no DC bias is put through it. DC bias, or having more electrons passing one way than the other when pumping AC, chemically breaks apart the liquid crystal. The AVR's LCD module uses precise timing to drive pixels forwards and backwards equally.

USB Interface

The AT90USB ^[2] series includes an on-chip USB controller. Some models are "function" only, while others have On-The-Go functionality to act as either a USB host (for interfacing with other slave devices) or as a USB slave (for interfacing with a USB master).

AVRs without built-in USB can use an external chip such as the PDIUSB12, or for a low-speed and minimal functionality device, a firmware-only approach.

Two firmware-only USB drivers are obdev ^[3], which is available under an Open Source compliant license with some restrictions, and USBtiny ^[4], which is licensed under the GPL.

Although these software implementation provide a very cheap way to add USB connectivity, they are limited to low-speed transfers, and tie up quite some AVR resources. Other hardware ICs which translate USB signals to RS-232 (serial) for the AVRs are available, from vendors such as FDTI. These ICs have the advantage of offloading the strenuous task of managing the USB connection with the disadvantage of being limited to the speed of the AVR's serial port.

Temperature Sensor

Some newer models have a built in temperature sensor hooked up to the ADC.

AVR Selection

The AVR microcontrollers are divided into three groups:

- tinyAVR
- AVR (Classic AVR)
- megaAVR

The difference between these devices mostly lies in the available features. The tinyAVR microcontrollers are usually devices with lower pin-count or reduced feature set compared to the megaAVRs. All AVR devices have the same basic instruction set and memory organization, so migrating from one device to another AVR is usually trivial.

The classic AVR is mostly EOL'd, and so new designs should use the Mega or Tiny series. Some of the classic AVRs have replacement parts in the mega series, e.g. the AT90S8515 is replaced by the mega8515.

Atmel provides a Parametric Product Table ^[5] which compares the memory, peripherals, and features available on the entire line of AVRs.

Hardware Design Considerations

Atmel provides the AVR Hardware Design Considerations ^[6] to assist the hardware designer. This document also shows the standard in-circuit serial programming connector.

AVR development/application boards

Butterfly Demo Board

The AVR Butterfly is a self-contained, battery-powered demonstration board running the ATMEL AVR ATmega169V Microcontroller. The board includes an LCD screen, joystick, speaker, serial port, RTC, flash chip, temperature, light & voltage sensors. The board has a shirt pin on its back and can be worn as a name badge.

The AVR Butterfly comes preloaded with software to demonstrate the capabilities of the microcontroller. Factory firmware can scroll your name, display the sensor readings, and show the time. Also, the AVR Butterfly has a piezo buzzer that can reproduce sound.

The AVR Butterfly demonstrates LCD driving by running a 14-segment, 6 alpha-numeric character display. However, the LCD interface consumes many of the I/O pins.

The Butterfly's ATmega169 CPU is capable of speeds up to 8Mhz, however it is factory set by software to 2Mhz to preserve the button battery life. A pre-installed bootloader program allows the board to be re-programmed with a standard RS-232 serial plug.

Ecos Technology produces a carrier board for the Butterfly ^[7] which provides a power supply, convenient connections to I/O ports, a DB-9 serial port (with level translator), and a large prototyping area.

STK500 starter kit

The STK500 starter kit and development system features ISP and high voltage programming for all AVR devices, either directly or through extension boards. The board is fitted with DIP sockets for all AVRs available in DIP packages.

Several expansion modules are available for the STK500 board. These include:

- STK501 - Adds support for microcontrollers in 64 pin TQFP packages.
- STK502 - Adds support for LCD AVRs in 64 pin TQFP packages.
- STK503 - Adds support for microcontrollers in 100 pin TQFP packages.
- STK504 - Adds support for LCD AVRs in 100 pin TQFP packages.
- STK505 - Adds support for 14 and 20 pin AVRs.
- STK520 - Adds support for 14 and 20 pin microcontrollers from the AT90PWM family.

Third-Party Boards

There are many AVR based development and/or application boards available from third parties, far too many to list all of them here.

- Arduino ^[8] is built around an ATmega8 or ATmega168, and is designed to be used with an open source development environment.
- AVR Based Support and Application Boards ^[9] by Mr. Pascal Stang from Stanford University
- GPMU40 ^[10] supports many different Atmel AVR chips
- Futurlec 2313 Board ^[11] (Note that the AT90S2313 is obsolete, and has been replaced by the ATtiny2313.)
- Olimex ^[12] produces many AVR-based development and prototyping boards, and has a list of links to example projects ^[13] as well.

Programming Interfaces

There are many means to get Program code onto the AVR.

In System Programming

Functionally, ISP is done through SPI, with some twiddling on Reset. As long as the SPI pins of the AVR aren't connected to anything disruptive, the AVR chip could stay soldered onto a board while reprogramming. All that's needed is a 6 pin plug, and an affordable PC adapter. This is the most common way to develop with an AVR.

Atmel's AVR ISP mkII connects to a PC's USB port and performs in-system programming using Atmel's software.

avrdude ^[14] (AVR Downloader UploaDEr) runs on Linux, FreeBSD, Windows, and Mac OS X, and supports a variety of in-system programming hardware, including Atmel AVR ISP mkII, Atmel JTAG ICE, older Atmel serial-port based programmers, and various third-party and "do-it-yourself" programmers.

High Voltage Programming

HV programming is mostly the backup mode on smaller AVRs. An 8 pin package doesn't leave many unique signal combinations to kick the AVR into programming mode. A 12 volt signal, however, is something the AVR should never see in a proper circuit.

Parallel Programming

Parallel is a backup mode on larger AVRs. It may be the only way to talk to an AVR that has a crazy oscillator fuse set. Parallel programming may also be faster, good if you have a modest production line going.

Bootloader Programming

Most AVR models can reserve a bootloader region, 256B - 2KB, where re-programming code can reside. At power on, the Bootloader runs first, and does some user-programmed determination whether to re-program, or jump to the main application. The code can re-program through any interface available, it could read an encrypted binary through an ethernet adapter if it felt like it. Atmel has application notes and code pertaining to any interface from RS-232 onwards.

Bootloaders are covered in detail in chapter [../Bootloaders and Bootsectors/](#).

No Programming at All

The AT90SC series of AVRs are available with a mask ROM rather than flash for program memory. [15]

Because of the large up-front cost and minimum order quantity, mask ROM is only cost-effective for a large production run.

Debugging Interfaces

The AVR offers several options for debugging, mostly involving on-chip debugging while the chip is in the target system.

JTAG

JTAG provides access to on-chip debugging functionality while the chip is running in the target system. JTAG allows accessing internal memory and registers, setting breakpoints on code, and single-stepping execution to observe system behaviour.

Atmel provides a series of JTAG adapters for the AVR.

1. The JTAGICE adapter ^[16] interfaces to the PC via a standard serial port. It is somewhat expensive by hobbyist standards at around US \$300, although much more affordable than many other microcontroller emulation systems. The JTAGICE has been EOL'ed, though it is still supported in AVR Studio and other tools.
2. The JTAGICE mkII ^[17] replaces the JTAGICE, and is similarly priced. The JTAGICE mkII interfaces to the PC via USB, and supports both JTAG and the newer debugWIRE interface.
3. The AVR Dragon ^[18] is a low-cost (approximately \$50) substitute for the JTAGICE mkII for certain target parts. The AVR Dragon provides in-system serial programming, high-voltage serial programming and parallel programming, as well as JTAG or debugWIRE emulation for parts with 32KB of program memory or less.

There are also several third party JTAG debuggers/reprogrammers for around \$40, such as those from Ecos and Olimex, as well as DIY projects, including Evertool ^[19] and Aquaticus ^[20]. These are clones of the original JTAGICE, and do not support the debugWire interface.

JTAG can also be used to perform a Boundary Scan test [21], which tests the electrical connections between AVRs and other Boundary Scan capable chips in a system. Boundary scan is well-suited for a production line; the hobbyist is probably better off testing with a multimeter or oscilloscope.

debugWIRE

debugWIRE™ is Atmel's solution for providing on-chip debug capabilities via a single microcontroller pin. It is particularly useful for lower pin count parts which cannot provide the four "spare" pins needed for JTAG. The JTAGICE mkII and the AVR Dragon support debugWIRE. debugWIRE was developed after the original JTAGICE release, and none of the JTAG clones support it.

Simulation

Simulation is not a debugging interface, *per se*, but simulation in software can be an effective debugging aid prior to committing a design to physical hardware.

AVR Studio^[22] simulates the AVR core at the assembly language level, and allows viewing and manipulation of all internal registers. HAPsim^[23] is a set of virtual devices that plug into AVR Studio. It provides LCDs, LEDs, buttons, and dumb terminals.

Other software packages exist which provide software simulation of the AVR core and peripherals are available.

- VMLab^[24] provides full-circuit simulation as well as a virtual oscilloscope. The debugger offers the ability to single step C code, as well as edit and rebuild winAVR programs. As of version 3.12, VMLab is freeware.
- AVRora^[25] is an "AVR simulation and analysis framework."
- Proteus^[26] provides schematic capture, PCB editing, and microcontroller simulation, including the AVR. The simulator "downloads" code into simulated AVR core. There is also support for a variety of virtual peripherals within the simulator.
- Simulavr^[27] is a free (GPLv2) simulator working with GDB and commonly used with avr-gcc.

Firmware Programming

A microcontroller won't do much without firmware; program code to tell the microcontroller what to do. Firmware for AVRs can be written in many different languages. Atmel published The Novice's Guide to AVR Development^[28], part of Atmel Applications Journal 2001 Summer^[29], which provides a brief tutorial in assembly language programming using AVR Studio.

AVR Assembly Language

- AVR Studio 4: Assembler, Simulator & WinAVR Compatible Project Editor^[30] (free download)
- AVR Instruction Set User Guide^[31]
- AVR Assembler Site^[1]
- AVR Assembler Forum^[32]
- AVR Assembler Tutorial^[33]

Some features of the AVR microprocessor can only be accessed with assembly language.

Assembly language will almost always produce the smallest code as compared to other compiled languages, and for this reason, it is a popular choice for applications that must fit into a very small code space.

AVR Studio is free of charge, but the program runs only on Windows, and its source code is not available. Two particular free/open-source assemblers for AVR are AVRA^[34] and Toms AVR Assembler^[35].

Ada

- AVR-Ada ^[36] at Sourceforge – Ada compiler from GCC and libraries for AVR.

BASIC

- The BASCOM-AVR development environment ^[37] is a BASIC Compiler for the AVR family. The IDE includes an editor, compiler, simulator and a lot of library functions. The demo version is limited to 4K code. The bascomp.exe command-line works in Wine ^[38].
- BASIC to C ^[39] has a free starter ATMEL AVR BASIC called RVK-BASIC, which runs on Windows. The downloaded version is limited to 100 lines of code.
- EEBasic ^[40] is an implementation of BASIC on a AVR Mega644 which only requires a terminal or terminal emulator to program; no PC based compiler (or other IDE) is used. Language extensions provide for use of the on-chip peripherals.

C

- GCC, the Gnu Compiler Collection, has thorough AVR support for C language.
 - Windows: WinAVR development tools ^[41], the Windows port of GCC. Now, it can even plug into the latest AVR Studio.
 - WinAVR and Butterfly Quickstart Guide ^[42]
 - Linux: Introduction to using AVR-GCC under Linux ^[43]
 - Debian and Ubuntu users, simply "apt-get install binutils-avr gcc-avr avr-libc"
 - Gentoo "emerge avr-libc avrdude crossdev" then "crossdev --target avr-softfloat-linux-gnu"
 - Development upon AVR GCC itself happens at the avr-gcc maillist ^[44].
 - Libraries for GCC
 - The avr-libc project ^[45] or avr-libc manual ^[46] describes the library you probably found bundled with AVR GCC.
 - Procyon AVRlib ^[47] An extensive AVR C Code library with example application code included.
 - A Doubly Linked Memory Manager for WinAVR ^[48]
 - It is possible to use C on the Tiny series which have no RAM (aside from the 32 registers), as demonstrated by Bruce Lightner ^[49].
- ImageCraft C ^[50] is an inexpensive commercial compiler.
- IAR ^[51] is an expensive commercial compiler.
- CodeVisionAVR ^[52] is a relatively inexpensive commercial C compiler for the AVR.

C++

- GCC also has support for C++ on the AVR.

Certain features of C++ are unsuitable for use on a smaller micro like the AVR due to the amount of memory required to implement them; these include exceptions and templates. However, when using a suitable subset of C++, the resultant code is of comparable size to its C language equivalent. One notable use of C++ on the AVR is the Arduino ^[53].

Java

- NanoVM ^[54] - Java virtual machine written in C for Atmel AVR microcontrollers with at least 8k flash.
- MCU Java source ^[55] - Java source to C source translator, which allows to write MCU programs in Java.

Pascal

- AVRco development environment ^[56] – IDE also includes simulator and HLL debugger with JTAG-ICE. Includes numerous library functions.
- MikroPascal ^[57] – Includes AVR-specific libraries, plus help and examples. Free version is limited to 4KB.
- Embedded Pascal ^[58] – IDE running under Windows 95,98 and NT. Language extensions provide for mixing AVR assembly in pascal code.

Forth

- ByteForth (wiki) ^[59] (purchase) ^[60] – Includes (dis)assembler, simulator, ISP-programmer and supports almost any AVR to date. Many library functions and example programs. Comes with complete (Dutch) language manual ^[61]. There is however an English language version with crash course included in the free but complete 2 kByte demo version ^[62]. ByteForth runs under DOS or any system that supports a working DOS-box as Linux, Windows-95, Windows-98SE, etc.
- amforth: atmega forth ^[63] is a compact Forth for AVR atmega micro controllers. It is released under the GPL 2 and is modeled after ANS 94.
- Avise (Atmel VIRTUAL Stack Engine) ^[64] is a "modified version of the Forth programming language." Avise is only available as HEX files to program into one of the supported AVRs; source code is not available. The author's web site also includes some PCB layouts for use with Avise.
- PFAVR ^[65] is a port of pForth ^[66] to the AVR.
- avrforth ^[67] is a 16-bit subroutine threaded forth kernel for atmel's avr series of microcontrollers.

Note that some Forth environments run interactively on the AVR. For example, Avise presents a console on the AVR's UART0 which can accept new word definitions and execute operations. No software (other than a terminal emulator) is required on the PC.

Python

- PyMite ^[68] is a subset of Python that runs on "any device in the AVR family that has at least 64 KiB program memory and 4 KiB RAM."

Scheme

- Scheme on the ATmega ^[69]?

References

Official Atmel Websites

- Atmel AVR Device Site ^[70]
- Atmel AVR Beta Site ^[71]
- Atmel AVR Support Site ^[72]

Wiki

- AVRfreaks wiki ^[73]
- Serial Programming:MAX232 Driver Receiver
- Wikiversity:Embedded System Engineering
- The massmind technical reference ^[74] has an AVR section ^[75], plus a lot of general information about embedded systems hardware and software. Massmind is almost a wiki.
- AVR wiki ^[76] *offline as of 2010-02-15*

Programming & Educational Websites

- AVRBeginners ^[77]
- AVR Assembly Language Site ^[1]
- AVR Machine Language ^[78]
- Free AVR Tutorials and Projects ^[79]

Mailing List & Forums

- The AVR Forum ^[78]
- AVRfreaks ^[80]
- AVRbeginners ^[77]
- AVR-Chat@Egroup.com ^[81]
- AVR-Chat & AVR-GCC mailing list ^[82]
- AVR Butterfly Group ^[83]

Books

- Dhananjay Gadre - *Programming and Customizing the AVR Microcontroller*, McGraw-Hill, 2000.
- Richard H. Barnett, Sarah A. Cox, Larry D. O'Cull - *Embedded C Programming and the Atmel AVR*, Thomson Delmar Learning, 2002.
- John Morton - *AVR: An Introductory Course*, Newnes, 2002.
- Claus Kuhnel - *AVR RISC Microcontroller Handbook*, Newnes, 1998.
- Joe Pardue - *C Programming for Microcontrollers, featuring ATMEL's AVR Butterfly and the free WinAVR Compiler*, Smiley Micros, 2005. Smiley Micros ^[84]
- Chuck Baird - *Programming Microcontrollers using Assembly Language*, Lulu.com, 2006. cbaird.net ^[85]
- Richard H. Barnett - *Embedded C Programming And The Atmel AVR*, Delmar Cengage Learning; 2 edition (June 5, 2006)

University Courses

The following courses are known to use the Atmel AVR as part of the curriculum.

- Introduction to Mechatronics, Santa Clara University ^[86]
 - Embedded System Design Laboratory, Stanford University ^[87]
 - Designing with Microcontrollers, Cornell University ^[88]
 - San Jose State University ^[89]
 - Microprocessors and Interfacing, UNSW ^[90]
-

AVR Projects

- Siwawi: AVR projects ^[91]
- MMC/SD memory cards for Atmel AVR ^[92]

References

- [1] http://www.atmel.com/dyn/resources/prod_documents/doc2513.pdf
- [2] http://www.atmel.com/dyn/products/devices.asp?family_id=607#1761
- [3] <http://www.obdev.at/products/avrusb/index.html>
- [4] <http://www.xs4all.nl/~dicks/avr/usbtiny/index.html>
- [5] http://www.atmel.com/dyn/products/param_table.asp?family_id=607&OrderBy=part_no&Direction=ASC
- [6] http://www.atmel.com/dyn/resources/prod_documents/doc2521.pdf
- [7] <http://ecrostech.com/AtmelAVr/Butterfly/index.htm>
- [8] <http://www.arduino.cc/>
- [9] <http://hubbard.engr.scu.edu/embedded/avr/boards/index.html>
- [10] <http://awce.com/avrhome.htm>
- [11] <http://www.futurlec.com/ATDevBoard.shtml>
- [12] <http://www.olimex.com>
- [13] <http://olimex.com/dev/avrprojects.html>
- [14] <http://savannah.nongnu.org/projects/avrdude>
- [15] <http://www.atmel.com/products/secureavr/overview.asp>
- [16] http://www.atmel.com/dyn/products/tools_card.asp?tool_id=2737
- [17] http://www.atmel.com/dyn/products/tools_card.asp?tool_id=3353
- [18] http://www.atmel.com/dyn/products/tools_card.asp?tool_id=3891
- [19] http://www.siwawi.arubi.uni-kl.de/avr_projects/evertool/
- [20] <http://aquaticus.info/jtag>
- [21] http://atmel.com/dyn/corporate/view_detail.asp?ref=&FileName=JTEGICE.html&SEC_NAME=product
- [22] http://atmel.com/dyn/products/tools_card.asp?tool_id=2725
- [23] <http://www.helmix.at/hapsim/>
- [24] <http://www.amctools.com/vmlab.htm>
- [25] <http://compilers.cs.ucla.edu/avrora/index.html>
- [26] <http://www.labcenter.co.uk/>
- [27] <http://www.nongnu.org/simulavr/>
- [28] http://www.atmel-grenoble.com/dyn/resources/prod_documents/novice.pdf
- [29] <http://www.atmel.com/journal/documents/issue1/journal.pdf>
- [30] http://www.atmel.com/dyn/products/tools_card.asp?tool_id=2725
- [31] http://www.atmel.com/dyn/resources/prod_documents/DOC0856.PDF
- [32] <http://avr.15.forumer.com/index.php?showforum=1>
- [33] <http://www.avr-asm-tutorial.net/index.html>
- [34] <http://avra.sourceforge.net>
- [35] <http://www.tavrasm.org>
- [36] <http://avr-ada.sourceforge.net/>
- [37] <http://www.mcselec.com/>
- [38] http://en.wikipedia.org/wiki/Wine_%28software%29
- [39] <http://www.bastoc.com>
- [40] <http://www.dandysolutions.com>
- [41] <http://winavr.sourceforge.net/>
- [42] <http://www.smileymicros.com/QuickStartGuide.pdf>
- [43] <http://www.linuxfocus.org/English/November2004/article352.shtml>
- [44] <http://lists.gnu.org/archive/html/avr-gcc-list/>
- [45] <http://savannah.nongnu.org/projects/avr-libc/>
- [46] <http://www.nongnu.org/avr-libc/user-manual/index.html>
- [47] <http://hubbard.engr.scu.edu/embedded/avr/avr-lib/index.html>
- [48] <http://www.jennaron.com.au/avr/DoublyLinkedMemory.html>
- [49] <http://lightner.net/avr/ATtiny/projects/README.txt>
- [50] <http://www.imagecraft.com/software/>
- [51] http://www.iar.com/index.php?show=5921_ENG&&page_anchor=http://www.iar.com/p5921/p5921_eng.php
- [52] <http://www.hpinfotech.ro/html/cvavr.htm>

- [53] <http://www.arduino.cc>
- [54] <http://www.harbaum.org/till/nanovm/index.shtml>
- [55] <http://mcujavasource.sourceforge.net/>
- [56] <http://e-lab.de/>
- [57] http://www.mikroelektronika.co.yu/english/product/compilers/mikropascal_avr/index.htm
- [58] <http://users.iafrica.com/r/ra/rainier/>
- [59] <http://forthfreak.de/index.cgi?ByteForth>
- [60] <http://www.forth.hccnet.nl/pr-bytef.html>
- [61] <http://www.forth.hccnet.nl/downloads/avrb207.pdf>
- [62] <http://www.forth.hccnet.nl/downloads/eng-avr.f.zip>
- [63] <http://amforth.sourceforge.net/>
- [64] <http://www.cinetix.de/avise/index.htm>
- [65] <http://claymore.engineer.gvsu.edu/~steriana/Software/index.html>
- [66] <http://www.softsynth.com/pforth/>
- [67] <http://krue.net/avrforth/>
- [68] <http://pymite.python-hosting.com/wiki/PyMite>
- [69] <http://1010.co.uk/atmegascheme.html>
- [70] <http://www.atmel.com/products/AVR/>
- [71] http://www.atmel.no/beta_ware/
- [72] <http://support.atmel.no/bin/customer>
- [73] <http://wiki.avrfreaks.net/>
- [74] <http://massmind.org/techref/>
- [75] <http://massmind.org/techref/atmel/avr/index.htm>
- [76] <http://avrwiki.com/>
- [77] <http://www.avrbeginners.net/>
- [78] <http://avr.15.forumer.com/>
- [79] <http://extremeelectronics.co.in/avr-tutorials/>
- [80] <http://www.avrfreaks.net/>
- [81] <http://groups.yahoo.com/group/AVR-Chat/>
- [82] <https://savannah.nongnu.org/projects/avr>
- [83] <http://groups.yahoo.com/group/AVRButterFly/>
- [84] <http://www.smileymicros.com>
- [85] <http://www.cbaird.net>
- [86] <http://mech143.engr.scu.edu/>
- [87] <http://www.stanford.edu/class/ee281/>
- [88] <http://instruct1.cit.cornell.edu/courses/ee476/>
- [89] <http://www.engr.sjsu.edu/bjfurman/courses/ME106/index.htm>
- [90] <http://www.cse.unsw.edu.au/~cs2121/>
- [91] http://www.siwawi.arubi.uni-kl.de/avr_projects/
- [92] <http://avenhaus.de/EEG/MMC/MMC.shtml>

Embedded Systems/ARM Microprocessors

The ARM architecture is a widely used 32-bit RISC processor architecture. In fact, the ARM family accounts for about 75% of all 32-bit CPUs, about 90% of all embedded 32-bit CPUs (Wikipedia: ARM architecture). ARM Limited licenses several popular microprocessor cores to many vendors. (ARM does not sell physical microprocessors). Originally ARM stood for *Advanced RISC Machines*.

Some cores offered by ARM:

- ARM7TDMI
- ARM9
- ARM11

Some examples of ARM based processors:

- Intel X-Scale (PXA-255 and PXA-270), used in Palm PDAs
- Philips LPC2000 family (ARM7TDMI-S core), LPC3000 family (ARM9 core)
- Atmel AT91SAM7 (ARM7TDMI core)
- ST Microelectronics STR710 (ARM7TDMI core)
- Freescale MCIMX27 series (ARM9 core)

The lowest-cost ARM processors (in the the LPC2000 series) have dropped below US\$ 5 in ones, which is less than the cost of many 16-bit and 8-bit microprocessors.

For further reading

- Embedded Systems/Assembly Language
- Embedded_Systems/Mixed_C_and_Assembly_Programming#ARM
- the ARM microcontroller wiki ^[1]
- Whirlwind Tour of ARM Assembly ^[2]
- GCC ARM Improvement Project ^[3] at the University of Szeged
- The ARM Linux Project ^[4]: Linux for all ARM based machines
- ARM ^[5]
- ARM developers discussion forums ^[6]

References

- [1] <http://www.open-research.org.uk/ARMuC/>
 - [2] <http://www.coranac.com/tonc/text/asm.htm>
 - [3] <http://www.inf.u-szeged.hu/gcc-arm/>
 - [4] <http://www.arm.linux.org.uk/docs/whatis.php>
 - [5] <http://arm.com/>
 - [6] <http://sevensandnines.com/>
-

Embedded Systems/AT91SAM7S64

The AT91SAM7S64 is a noteworthy instance of the ARM processor architecture because of the availability of affordable prototyping hardware (1 ^[1], 2 ^[2], 3 ^[3]) and of on-line tutorial information (1 ^[4], 2 ^[5]). There is a bootloader ^[6] for it as well.

Image of Olimex board at <http://www.olimex.com/dev/images/ARM/ATMEL/SAM7-Hxxx-1.jpg>

There are a number of interesting projects documented for this controller (1 ^[7], 2).

My hope for this page is to work up a getting-started guide for the cheapest SAM7 board I can find, which is thusfar the Olimex board ^[1].

References

- [1] <http://www.olimex.com/dev/sam7-h64.html>
- [2] http://www.sparkfun.com/commerce/product_info.php?products_id=614
- [3] http://www.atmel.com/dyn/products/tools_card.asp?tool_id=3784
- [4] <http://www.doctort.org/adam/nerd-notes/getting-started-with-the-olimex-sam7-p256.html>
- [5] http://www.atmel.com/dyn/resources/prod_documents/doc6293.pdf
- [6] http://claymore.engineer.gvsu.edu/%7Esteriana/Software/Sam_I_Am/index.html
- [7] http://www.siwawi.arubi.uni-kl.de/avr_projects/arm_projects/index_at91.html

Embedded Systems/Cypress PSoC Microcontroller

The Cypress PSoC microcontroller, like all microprocessors, has its own quirks.

When you can't figure something out, and this FAQ doesn't help, the forums at

- <http://www.psocdeveloper.com/>, under "Forums"
- <http://www.psoczone.com/>, under "Forums"
- <http://www.cypress.com/>, under "Technical Support" then "Discussion Boards".

are a good place to start.

User Documentation

- Embedded Systems/Cypress PSoC Microcontroller/Application Notes
- Embedded Systems/Cypress PSoC Microcontroller/User Modules

Cypress PSoC FAQ

(If the answers I've sketched in are incorrect, *please* correct them).

Which PSoC to use

Some people recommend that hobbyists use the largest and most capable chip available in a DIP package -- as of 2008-09, that is the CY8C29466 28-DIP.

CY8C29466 28-DIP -- I suspect this is the same chip as in the CY8C29466 28-SSOP or 28-SOIC, CY8C29566 44-TQFP, CY8C29666 48-SSOP or 48-QFN, CY8C29866 100TQFP. These parts have more Flash (32 KByte Flash) and more RAM (2 KByte RAM) and more digital blocks (and analog blocks?) than any other PSoC available.

CY8C27143 8-DIP: more Flash (16 KByte Flash) and more digital blocks (and analog blocks?) and just as much RAM (256 bytes) of any 8-pin PSoC.

CY8CNP102: not yet available (as of 2008-09), but expected to have 256 KByte non-volatile storage and 2 KByte RAM.

(analogous to Embedded Systems/PIC Microcontroller#Which PIC to Use)

other FAQs

Q: It's not working!

A: Have you gone through the "Software Checklist: Tips on Using PSoC" ^[1] by Zlatko Saravanja, 2004 ? Tips on using the PSoC ^[2] ? PSoC(R) Technical Reference Manual (TRM) ^[3]? "Getting Started with PSoC (READ THIS FIRST) - AN2010" ^[4]?

Q: I'm having problems trying to use my PSoC MiniProg to program a CY8C26443.

A: The Mini programmer does not support the 25/26 families. You will have to use ICE-4000 or the ICE-cube. Or switch to a chip that the MiniProg does support, such as the 27/29 families. [FIXME: make a list of chips, and mark each with "Y -- known to work with MiniProg", "N -- doesn't work with MiniProg", or "? -- unknown"]. <http://www.psocdeveloper.com/forums/viewtopic.php?t=2057> <http://www.psocdeveloper.com/forums/viewtopic.php?t=2022> (Should we make this a table, with the various programmers -- m8cprogs open hardware ^[5], MiniProg, ICE-cube, etc. vs. the various chips?).

interrupt handler

Q: How do I write an interrupt handler in C?

A: See ^[2] "Software Checklist: Tips on Using PSoC" ^[1]. Also, inside the PSoC IDE, choose "Help", "Documentation", then "C Language Compiler User Guide" ^[6]. More discussion: <http://www.psocdeveloper.com/forums/viewtopic.php?t=2089> and "Tips on using the PSoC" <http://www.psocdeveloper.com/old/index.php?page=8&mode=article&k=11> <http://www.psocdeveloper.com/forums/viewtopic.php?t=1902> <http://www.psocdeveloper.com/forums/viewtopic.php?t=2102> <http://www.psocdeveloper.com/forums/viewtopic.php?t=2099> <http://www.psocdeveloper.com/forums/viewtopic.php?t=2089>

warning: area 'myproject_RAM' not defined

Q: I'm getting the message:

```
warning: area 'myproject_RAM' not defined in startup file './obj/boot.o' and
does not have an link time address.
```

How do I get rid of that warning?

A: (from <http://www.psocdeveloper.com/forums/viewtopic.php?t=1761>) Open the boot.tpl. In the end, you will see many areas defined in RAM. Add the following line below the already existing RAM area declarations, just above the AREA bss declaration: AREA myproject_RAM (RAM, REL, CON) Then save the boot.tpl file and "Config" >> "generate application".

lookup table

Q: How do I create a lookup table in assembly language?

A: See <http://www.psocdeveloper.com/old/index.php?page=8&mode=article&k=10> (Um ... don't you also have to disable "code compression" during that table?)

gotchas

Q: Any gotchas I should watch out for?

A: "Tips on using the PSoC" <http://www.psocdeveloper.com/old/index.php?page=8&mode=article&k=11>

simulator and other programming languages

Q: What alternatives are there to the (free) PSoC Designer and the ImageCraft PSoC C compiler ? (Because they haven't yet been ported to Linux)

A1: m8cutils: <http://m8cutils.sourceforge.net/> Werner is developing an assembler and a simulator and a programmer for Linux [7] [8] <http://www.psocdeveloper.com/forums/viewtopic.php?t=1616>

A2: Forth/PSoC Forth: Christopher Burns wrote a PSoC Forth. The source code is available at http://www.psocdeveloper.com/tools/misc_dev_tools/. As of 2007, David Cary is maintaining it at Forth/PSoC Forth (was: <http://forthfreak.net/index.cgi?M8cForth>). This Forth compiler will work with Linux, Mac, Windows, Solaris, Palm, and even VT-100 dumb terminals.

I/O pins

Q: How do I make output pins Hi and Lo ?

A: Usually you connect the output pins to some digital "module" (such as a PWM block). If none of the "modules" do what you want, you can set them in software -- see The GPIO reference http://www.psocdeveloper.com/articles/fundamentals_of_psoc_gpio/the_gpio_read_write_example_project <http://www.psocdeveloper.com/docs/example-project.html> GPIO Help <http://www.psocdeveloper.com/forums/viewtopic.php?t=83> <http://www.psocdeveloper.com/forums/viewtopic.php?t=1950> (Warning: Be aware that the PRTxDR register is write-only -- you can't read back from that register. If you read from the PRTxDR address, you are directly reading the value at the pins, which is often *not* what you just wrote. If you incorrectly assume they will be the same, you will sooner or later be bitten by the read-modify-write problem.). (Warning: "you cannot read a port that is configured for "interrupt on change from last read" from main code and have the ISR feature work reliably." See <http://www.psocdeveloper.com/forums/viewtopic.php?t=2094>). "How to set a single port pin?" http://www.cypress.com/portal/server.pt/gateway/PTARGS_0_652034_739_205_211_43/http%3B/sjapp20/cf_apps/design_supports/forums/messageview.cfm?catid=3&threadid=18055 PSoC I/O Pin-Port Configuration - AN2094 http://www.cypress.com/portal/server.pt?space=CommunityPage&control=SetCommunity&CommunityID=285&PageID=552&shortlink=DA_240474 "Mr. Zee's intro to GPIO", "Basic fundamentals of GPIO" by mrzee <http://www.psocdeveloper.com/forums/viewtopic.php?t=2058> <http://www.psocdeveloper.com/forums/viewtopic.php?t=1667>

Q: What should I do with pins I'm not using ? A:???

QThe XRES should be connected to ... what ?

A: Although it has an internal pull down it is good practice to connect it to ground via a 470,1K,... ohm resistor.

I/O pins

Q: How do I read the state of a single digital input pin?

A: Usually you connect the input pins to some digital "module" (such as a timer block). If none of the "modules" do what you want, you can set them in software -- see the GPIO references in the previous question.

interrupts

Q: How do I set up a digital input pin to trigger an interrupt? Where do I put the code to handle that interrupt?

A: ??? <http://www.psocdeveloper.com/forums/viewtopic.php?t=1586> "How to determine source of GPIO interrupt" <http://www.psocdeveloper.com/forums/viewtopic.php?t=1524>

How many bytes of stack do I really need?

Q: I'm running out of RAM -- How many bytes of stack do I really *need*?

A: the "stalkwalk" utility does static stack analysis <http://www.psocdeveloper.com/forums/viewtopic.php?t=9> gives a conservative count of how many bytes are needed. (It still needs some work ...).

RS485

Q: How do I connect my PSoC to a RS485 bus?

A1: <http://www.psocdeveloper.com/forums/viewtopic.php?t=1640> mentions "Interrupt on 9th bit ... Application Note AN2269 "Implement 9-Bit Protocol on the PSoC™ UART" "

A2: Half-duplex issues are discussed at <http://www.psocdeveloper.com/forums/viewtopic.php?t=1731> <http://www.psocdeveloper.com/forums/viewtopic.php?t=2397>

UART

Q: The UART isn't working! I'm pulling out my hair!

A: Please restate in the form of a question.

mixing C and assembly language

Q: How do I call a C function from assembly?

A: You can call C functions in assembly by adding an underscore before the function name. For example, if you want to call a C function called foo() from assembly you would use

```
call _foo
```

. This applies for C functions that do not take any parameters. If you want to call functions that take parameters then you need to pass these parameters to the stack before calling it. The parameters are pushed from right to left and MSB first. Example: C function to be called:

```
void foo(WORD Arg1, WORD Arg2)
```

assembly code:

```
mov A, [Arg2 MSB]
push A
mov A, [Arg2 LSB]
push A
mov A, [Arg1 MSB]
push A
mov A, [Arg1 LSB]
```

```
push A
xcall _foo
add SP, -4
```

interrupts

Q: How do I call a C function from an assembly ISR?

A1: The simple method: Use "#pragma interrupt_handler" to mark the C function. From the ISR side, LJUMP to the C function (don't bother pushing anything on the stack). Refer to the answer of question "How do I write an interrupt handler in C?". The C function marked with "#pragma interrupt_handler" can call normal C functions (and normal assembly functions) -- but normal C functions *cannot* call any C function marked with "#pragma interrupt_handler".

A2: If you insist that your assembly ISR *must* "call" a normal C function, it gets tricky.

You need to take care of saving and restoring virtual registers used by the C function. Open the .lst file and check what are the virtual registers used by the C function. For example, if the C function foo() uses virtual registers __r0 and __r1: (assumes void foo(void). See "How do I call a C function from assembly?" if foo has parameters.)

```
mov A, [__r0]
push A
mov A, [__r1]
push A
xcall _foo
pop A
mov [__r1], A
pop A
mov [__r0], A
```

Apart from saving and restoring virtual registers, A and X also have to be saved and restored. In case you are using a program with LMM enabled, then the paging mode has to be restored to native paging before calling the C function and also the paging registers have to be saved and restored.

This is all stuff that the compiler would have handled automatically for you, if you had marked that C function with "#pragma interrupt_handler", and had your assembly language LJUMP to that C function.

object code size

Q: How can I optimize object code size generated by the PSoC C Compiler ?

A1: On MCUs with more than 256 bytes of SRAM, do not use LMM if at all possible. The overhead from page management is significant.

A2: Do not use 32-bit variables unless absolutely necessary.

A3: If possible, stick to 8-bit variables of type BYTE, and only use 16-bit WORDs if necessary.

A4: If readability does not overly suffer, try to only use global variables.

A5: Stay away from pointers to structures, and arrays of structures. This particularly means avoiding the passing of structure pointers to functions.

A6: Consider limiting the number of function parameters, and making common data global that can be accessed directly by all functions.

JTAG

Q: Does the PSoC do JTAG ?

A: No. But much of the JTAG functionality can be done other ways. PSoC boundary scan using "m8cbscan" ^[9]

Q: Is there a way that the program running in the PSoC can modify the flash in that same PSoC? (instead of the normal process of burning the program into the PSoC, then never modifying the program) ?

A1: ... use the EEPROM module ...

A2: ... some tips in the "Flash Write Routine" ^[10] thread ...

A3: ... Forth/PSoC Forth gives an example of a program running in the PSoC that modifies the flash in that same PSoC.

further reading

- Forth/PSoC Forth gives an example of PSoC assembly language
- "Homemade MIDI turntable" ^[11] by casainho very briefly shows a schematic and a photo of a PCB with a CY7C63723 microcontroller on it (inside an optical mouse) ... although the final project ends up using an Atmel AVR instead.

References

- [1] http://www.psocdeveloper.com/docs/articles/tips_on_using_the_psoc/software_checklist/
- [2] <http://www.psocdeveloper.com/articles/tips-on-using-the-psoc/introduction.html>
- [3] http://www.cypress.com/portal/server.pt?space=CommunityPage&control=SetCommunity&CommunityID=285&PageID=552&shortlink=DA_550707
- [4] <http://www.cypress.com/design/AN2010>
- [5] <http://www.psocdeveloper.com/forums/viewtopic.php?t=2075>
- [6] http://www.cypress.com/portal/server.pt?space=CommunityPage&control=SetCommunity&CommunityID=285&PageID=552&shortlink=DA_242412
- [7] <http://www.psocdeveloper.com/forums/viewtopic.php?t=1744>
- [8] <http://www.psocdeveloper.com/forums/viewtopic.php?t=1685>
- [9] <http://www.psocdeveloper.com/forums/viewtopic.php?t=2693>
- [10] <http://www.psocdeveloper.com/forums/viewtopic.php?t=186&postdays=0&postorder=asc&start=60>
- [11] <http://casainho.net/tiki-index.php?page=Homemade+midi+turntable>

Appendices

Embedded Systems/Common Protocols

This is a list of common protocols used in embedded systems. Eventually, this list will become hyperlinks to sources of information on each.

- I²C
- CAN
- BlueTooth
- InfraRed
- ZigBee
- SPI
- RS-232
- USB
- MINES ^[1] (Microcontroller Interpreter for Networked Embedded Systems) was designed for very small embedded systems (see Gallery of MINES Devices ^[2]).
- the Tiny Embedded Network ^[3]
- IEEE Standard for Sensor Transducer Interface ^[4]
- the three byte Mini SSC protocol ^[5]
- JTAG
- NTSC / PAL television video output: w:TV Typewriter, Generating TV signal by PSoC ^[6], Generating TV signal with the PICs ^[7], PIC Breakout ^[8], ... Parallax Propeller has a video generator ...

If you are designing a new protocol because none of these meet your needs (which are what, exactly?), you may want to consider the w:Network protocol design principles, and post rough drafts to the PICA standards wiki ^[9] for expert review.

References

- [1] <http://www.artisllc.com/solutions/embedded/mines/>
 - [2] http://www.artisllc.com/solutions/embedded/mines/mines_gallery.html
 - [3] <http://members.tripod.com/~mdileo/>
 - [4] <http://standards.ieee.org/announcements/electindustrange.html>
 - [5] <http://seetron.com/ssc.htm>
 - [6] http://antiradio.narod.ru/raznoe/cypress/tv_generating/tvgenerating.html
 - [7] <http://www.uelectronics.info/generating-tv-signal-pics>
 - [8] <http://www.acm.uiuc.edu/sigarch/projects/breakout/>
 - [9] <http://interwiki.sourceforge.net/cgi-bin/picawiki.pl/StartingPoint>
-

Embedded Systems/Where To Buy

This page will list some places where the reader can buy some of the hardware discussed in this book. Some of the embedded systems can be purchased for relatively cheap (some PIC microcontrollers will cost 5\$ or less), and therefore the reader can purchase them for cheap and play around with them. Some of the embedded computers are relatively expensive, but these ones are very useful for home projects, because larger expensive boards will be more versatile, and will have more gadgets and gizmos to play with.

- JK Microsystems ^[1] This company has a number of good, solid embedded computers, many of which are i386 compatible. Many of these computers come with DOS preloaded, but an RTOS called "eRTOS" is available for free. Many of these computers come with ethernet extensions, so they can be used to perform simple web-based tasks (IRC bot, or simple web server, for instance).
- Technologic Inc. ^[2] This company offers many moderate to high-end microprocessors with a number of available add-ons including PCMCIA cards (for things like wireless internet cards). Many of these systems are pre-loaded with a linux distro called "TS-Linux"
- ZWorld ^[3] This webpage offers a number of embedded systems and development kits. The flagship model is called the "Rabbit Core", and is a very fast and flexible microprocessor. These core units can be incorporated into a number of different "single board computers", for maximum flexibility. RabbitCore processors are programming in a proprietary language called "Dynamic C", which is similar to standard C.
- Rentron ^[4] This webpage is basically a large catalogue for a number of different components including microcontrollers, microprocessors, transmitters, receivers, encoders, decoders, etc..
- <http://www.atmel.com> This company sells a large number of different types of components, including ARM chips, an 8051-compatible chip, and a proprietary 8-bit microprocessor called the "Atmel AVR", and a 4-bit microprocessor called the "MARC4". Also sells a number of DSP modules, and controllers.
- Embedded Planet ^[5] This company offers numerous fully customizable PowerPC, XScale, ARM and MIPS based embedded computers with multiple bootloader and operating system choices.

further reading

- Open Circuits wiki: list of electronics suppliers ^[6]

References

[1] <http://www.jkmicro.com/>

[2] <http://www.embeddedx86.com/>

[3] <http://www.zworld.com/>

[4] <http://www.rentron.com>

[5] <http://www.embeddedplanet.com>

[6] <http://opencircuits.com/Supplier>

Embedded Systems/Resources

Wikimedia Resources

- Robotics
- Communication Systems
- Digital Signal Processing
- List of emulators
- Wikiversity:Embedded System Engineering
- Serial Programming Book
- Programmable Logic
- Parallel Computing and Computer Clusters
- Electric Circuits
- Analog and Digital Conversion
- Embedded Control Systems Design

Related Programming Resources

- Ada Programming
- Assembly Language
- C Programming
- C++ Programming
- Forth
- Software Engineers Handbook

Web Resources

- "AN887: Microcontrollers made easy" ^[1] 2002 a gentle introduction to microcontrollers in general and some of the things they do, with lots of pictures.
 - Knowledge and concepts behind VLSI chip design ^[2]
 - Embedded System description in simple words ^[3]
 - Microcontrollers Forum ^[4]
 - <http://www.EmbeddedRelated.com/>
 - Embedded White Papers, Downloads, Companies, News, Articles ^[5]
 - Microcontroller based free projects. ^[6]
 - Embedded Systems Design Magazine ^[7] has articles such as "The basics of programming embedded processors: Part 1" ^[8] by Wayne Wolf
 - Embedded Systems Resources ^[9]
 - Electronics Components Tutorials for Robotics ^[10]
 - Dedicated Systems Magazine ^[11]
 - RTC Magazine ^[12]
 - COTS Journal ^[13]
 - Portable Design Magazine ^[14]
 - PKG Magazine ^[15]
 - www.embeddedcommunity.com ^[16]
 - "Tools for Embedded Developers" ^[17] recommended by the Ganssle Group
 - Embedded System News ^[18]
-

- "Technical Report on C++ Performance" ^[19] by Dave Abrahams et. al. has a lot of tips for using C++ in embedded systems.

Books

- Barr, Michael et al. "Embedded Systems Dictionary" ISBN 1578201209
- Predko, Myke. "Programming and Customizing PICmicro Microcontrollers", McGraw Hill, 2002. ISBN 0071361723
- Pont, Michael J. "Embedded C" Addison Wesley, 2002. ISBN 020179523X
- Berger, Arnold S. "Embedded Systems Design: An Introduction to Processes, Tools and Techniques" CMP Books, 2001. ISBN 1578200733

References

- [1] <http://www.st.com/stonline/books/pdf/docs/4966.pdf>
- [2] <http://www.vlsichipdesign.com>
- [3] <http://embedded-system.net/reference/what-is-embedded-system/>
- [4] <http://www.nabble.com/MicroControllers-f2055.html>
- [5] <http://www.embeddedstar.com/>
- [6] <http://www.endtas.com/robot>
- [7] <http://embedded.com/>
- [8] <http://embedded.com/design/multicore/201200638>
- [9] <http://www.eg3.com/>
- [10] http://www.norcom-electronics.com/electronics_tutorials.php
- [11] <http://omimo.be/>
- [12] <http://www.rtcmagazine.com/>
- [13] <http://www.cotsjournalonline.com/>
- [14] <http://www.portabledesign.com/>
- [15] <http://www.pkgmagazine.com/>
- [16] <http://www.embeddedcommunity.com/>
- [17] <http://www.ganssle.com/tools.htm>
- [18] <http://embeddedsystemnews.com/>
- [19] <http://www.research.att.com/~bs/performanceTR.pdf>

Embedded Systems/Licensing



Permission is granted to copy, distribute and/or modify this document under the terms of the **GNU Free Documentation License**, Version 1.2 or any later version published by the Free Software Foundation; with no Invariant Sections, no Front-Cover Texts, and no Back-Cover Texts. A copy of the license is included in the section entitled "GNU Free Documentation License."

Article Sources and Contributors

- Wikibooks:Collections/Embedded Systems** *Source:* <http://en.wikibooks.org/w/index.php?oldid=1339120> *Contributors:* Whiteknight
- Wikibooks:Collections Preface** *Source:* <http://en.wikibooks.org/w/index.php?oldid=1795903> *Contributors:* Adrignola, Jomegat, Magesha, Mike.lifeguard, RobinH, Whiteknight
- Embedded Systems/Embedded Systems Introduction** *Source:* <http://en.wikibooks.org/w/index.php?oldid=1826627> *Contributors:* AdRiley, Az1568, DavidCary, Hagindaz, Herbythyme, Jedikaiti, Jomegat, Mcleodm, QuiteUnusual, Recent Runes, SPat, Webaware, Whiteknight, YMS, 33 anonymous edits
- Embedded Systems/Terminology** *Source:* <http://en.wikibooks.org/w/index.php?oldid=1604590> *Contributors:* DavidCary, Intgr, Manikandan.ts, Whiteknight, 7 anonymous edits
- Embedded Systems/Microprocessor Introduction** *Source:* <http://en.wikibooks.org/w/index.php?oldid=1826643> *Contributors:* Adrignola, DavidCary, Jedikaiti, Whiteknight, 2 anonymous edits
- Embedded Systems/Embedded System Basics** *Source:* <http://en.wikibooks.org/w/index.php?oldid=1816057> *Contributors:* DavidCary, Hagindaz, Icewedge, Javariel, Mbluett, Recent Runes, Whiteknight, 8 anonymous edits
- Embedded Systems/Microprocessor Architectures** *Source:* <http://en.wikibooks.org/w/index.php?oldid=1394714> *Contributors:* DavidCary, Jamin1001, Rhartness, Whiteknight, 1 anonymous edits
- Embedded Systems/Programmable Controllers** *Source:* <http://en.wikibooks.org/w/index.php?oldid=1603920> *Contributors:* DavidCary, Herbythyme, Jamin1001, Panic2k4, Uhussein, Whiteknight, 3 anonymous edits
- Embedded Systems/Floating Point Unit** *Source:* <http://en.wikibooks.org/w/index.php?oldid=1826685> *Contributors:* DavidCary, Jedikaiti, Whiteknight, 2 anonymous edits
- Embedded Systems/Parity** *Source:* <http://en.wikibooks.org/w/index.php?oldid=1826714> *Contributors:* DavidCary, Dragontamer, Jedikaiti, Whiteknight, 3 anonymous edits
- Embedded Systems/Memory** *Source:* <http://en.wikibooks.org/w/index.php?oldid=1826719> *Contributors:* DavidCary, Jedikaiti, Webaware, Whiteknight, 5 anonymous edits
- Embedded Systems/Memory Units** *Source:* <http://en.wikibooks.org/w/index.php?oldid=1286869> *Contributors:* Whiteknight, 3 anonymous edits
- Embedded Systems/C Programming** *Source:* <http://en.wikibooks.org/w/index.php?oldid=1800294> *Contributors:* Adrignola, DavidCary, Eigendude, Herbythyme, Jomegat, Mikiemike, Panic2k4, Special Ed, Thenub314, Tigerraj32, Whiteknight, Zohair.ahmad, 9 anonymous edits
- Embedded Systems/Assembly Language** *Source:* <http://en.wikibooks.org/w/index.php?oldid=1792729> *Contributors:* Adrignola, Darklama, DavidCary, NipplesMeCool, Whiteknight, 4 anonymous edits
- Embedded Systems/Mixed C and Assembly Programming** *Source:* <http://en.wikibooks.org/w/index.php?oldid=1758203> *Contributors:* Adrignola, DavidCary, Mikiemike, Rajdivecha, Recent Runes, Whiteknight, 17 anonymous edits
- Embedded Systems/IO Programming** *Source:* <http://en.wikibooks.org/w/index.php?oldid=1555639> *Contributors:* DavidCary, QuiteUnusual, Whiteknight, 2 anonymous edits
- Embedded Systems/Serial and Parallel IO** *Source:* <http://en.wikibooks.org/w/index.php?oldid=1407949> *Contributors:* Darklama, DavidCary, Kwhitefoot, Mikiemike, Robert Horning, Whiteknight, 9 anonymous edits
- Embedded Systems/Super Loop Architecture** *Source:* <http://en.wikibooks.org/w/index.php?oldid=894156> *Contributors:* Darklama, Fpeelo, Whiteknight, 5 anonymous edits
- Embedded Systems/Protected Mode and Real Mode** *Source:* <http://en.wikibooks.org/w/index.php?oldid=890012> *Contributors:* RohitUpadhyay, Whiteknight
- Embedded Systems/Bootloaders and Bootsectors** *Source:* <http://en.wikibooks.org/w/index.php?oldid=1292577> *Contributors:* DavidCary, Jamin1001, Whiteknight, 2 anonymous edits
- Embedded Systems/Terminate and Stay Resident** *Source:* <http://en.wikibooks.org/w/index.php?oldid=890014> *Contributors:* Tannersf, Whiteknight
- Embedded Systems/Real-Time Operating Systems** *Source:* <http://en.wikibooks.org/w/index.php?oldid=1731460> *Contributors:* DavidCary, Fxyoung, IRelayer, Jomegat, Whiteknight, Zephram Stark, 24 anonymous edits
- Embedded Systems/Threading and Synchronization** *Source:* <http://en.wikibooks.org/w/index.php?oldid=1087168> *Contributors:* DavidCary, Derbeth, Maksym.yehorov, Whiteknight, 3 anonymous edits
- Embedded Systems/Interrupts** *Source:* <http://en.wikibooks.org/w/index.php?oldid=1221443> *Contributors:* DavidCary, Maksym.yehorov, Whiteknight, 4 anonymous edits
- Embedded Systems/RTOS Implementation** *Source:* <http://en.wikibooks.org/w/index.php?oldid=1606849> *Contributors:* DavidCary, Whiteknight, 5 anonymous edits
- Embedded Systems/Locks and Critical Sections** *Source:* <http://en.wikibooks.org/w/index.php?oldid=1715779> *Contributors:* DavidCary, Marty Boogaart, QuiteUnusual, Whiteknight, 1 anonymous edits
- Embedded Systems/Common RTOS** *Source:* <http://en.wikibooks.org/w/index.php?oldid=1701649> *Contributors:* Az1568, ChrisRing, DavidCary, Tomtailor, Whiteknight, 9 anonymous edits
- Embedded Systems/Common RTOS/Palm OS** *Source:* <http://en.wikibooks.org/w/index.php?oldid=1461752> *Contributors:* Whiteknight
- Embedded Systems/Common RTOS/Windows CE** *Source:* <http://en.wikibooks.org/w/index.php?oldid=890022> *Contributors:* Hagindaz, Whiteknight, 2 anonymous edits
- Embedded Systems/Common RTOS/DOS** *Source:* <http://en.wikibooks.org/w/index.php?oldid=1627681> *Contributors:* DavidCary, Robert Horning, Whiteknight
- Embedded Systems/Linux** *Source:* <http://en.wikibooks.org/w/index.php?oldid=1538412> *Contributors:* Adrignola, DavidCary
- Embedded Systems/Interfacing Basics** *Source:* <http://en.wikibooks.org/w/index.php?oldid=917624> *Contributors:* DavidCary, Hagindaz, Whiteknight, 2 anonymous edits
- Embedded Systems/External ICs** *Source:* <http://en.wikibooks.org/w/index.php?oldid=890025> *Contributors:* Whiteknight
- Embedded Systems/Low-Voltage Circuits** *Source:* <http://en.wikibooks.org/w/index.php?oldid=1601709> *Contributors:* DavidCary, Whiteknight, 1 anonymous edits
- Embedded Systems/High-Voltage Circuits** *Source:* <http://en.wikibooks.org/w/index.php?oldid=1169531> *Contributors:* DavidCary, Whiteknight, 3 anonymous edits
- Embedded Systems/Particular Microprocessors** *Source:* <http://en.wikibooks.org/w/index.php?oldid=1792735> *Contributors:* Adrignola, Daleh, DavidCary, Whiteknight, 11 anonymous edits
- Embedded Systems/Intel Microprocessors** *Source:* <http://en.wikibooks.org/w/index.php?oldid=1693437> *Contributors:* DavidCary, Hagindaz, Watom, Whiteknight, 5 anonymous edits
- Embedded Systems/PIC Microcontroller** *Source:* <http://en.wikibooks.org/w/index.php?oldid=1791205> *Contributors:* A. B., Az1568, DavidCary, Imp Wit, Jomegat, Stingraze, Unihedron, Whiteknight, 44 anonymous edits
- Embedded Systems/8051 Microcontroller** *Source:* <http://en.wikibooks.org/w/index.php?oldid=1784282> *Contributors:* AdRiley, Adrignola, Derbeth, Eibwen, Enator24, Herbythyme, Jomegat, Kayau, Mattb112885, Nkrypt, Robert Horning, Webaware, Whiteknight, 56 anonymous edits
- Embedded Systems/Freescale Microcontrollers** *Source:* <http://en.wikibooks.org/w/index.php?oldid=1755143> *Contributors:* Daleh, DavidCary, Pharuo, Whiteknight, 8 anonymous edits

Embedded Systems/Atmel AVR *Source:* <http://en.wikibooks.org/w/index.php?oldid=1765318> *Contributors:* AndrewHarvey4, DavidCary, DepartedUser3, Derbeth, G-schmidt-hp, Geocachernemesis, Herbythyme, lamunknown, Jguk, Jomegat, Killertoffy, Krischik, Mike.lifeguard, Mrbill, Opodeldoe, Reece, Stevenyu, Sunlight2, Suruena, Villagplh, Webaware, Whiteknight, Yan, 308 anonymous edits

Embedded Systems/ARM Microprocessors *Source:* <http://en.wikibooks.org/w/index.php?oldid=1857066> *Contributors:* Adrignola, DavidCary, Eigendude, Jguk, QuiteUnusual, 5 anonymous edits

Embedded Systems/AT91SAM7S64 *Source:* <http://en.wikibooks.org/w/index.php?oldid=1538408> *Contributors:* Adrignola, WillWare

Embedded Systems/Cypress PSoC Microcontroller *Source:* <http://en.wikibooks.org/w/index.php?oldid=1752297> *Contributors:* Aki009, DavidCary, Graaja, KaiMartin, Recent Runes, 9 anonymous edits

Embedded Systems/Common Protocols *Source:* <http://en.wikibooks.org/w/index.php?oldid=989112> *Contributors:* DavidCary, Robert Horning, Whiteknight, 2 anonymous edits

Embedded Systems/Where To Buy *Source:* <http://en.wikibooks.org/w/index.php?oldid=1287282> *Contributors:* Aaronsells, DavidCary, Whiteknight

Embedded Systems/Resources *Source:* <http://en.wikibooks.org/w/index.php?oldid=1563941> *Contributors:* DavidCary, Embeddedsystemnews, Whiteknight, 1 anonymous edits

Embedded Systems/Licensing *Source:* <http://en.wikibooks.org/w/index.php?oldid=890037> *Contributors:* Whiteknight

Image Sources, Licenses and Contributors

Image:Wikibooks-logo-en-noslogan.svg *Source:* <http://en.wikibooks.org/w/index.php?title=File:Wikibooks-logo-en-noslogan.svg> *License:* logo *Contributors:* User:Bastique, User:Ramac

File:LED circuit.svg *Source:* http://en.wikibooks.org/w/index.php?title=File:LED_circuit.svg *License:* Creative Commons Attribution-Sharealike 2.5 *Contributors:* Dmccreary, 1 anonymous edits

Image:Pinouts8051.jpg *Source:* <http://en.wikibooks.org/w/index.php?title=File:Pinouts8051.jpg> *License:* Public Domain *Contributors:* Az1568, Mike.lifeguard, Nkrypt, 1 anonymous edits

File:Heckert GNU white.svg *Source:* http://en.wikibooks.org/w/index.php?title=File:Heckert_GNU_white.svg *License:* Free Art License *Contributors:* Aurelio A. Heckert <aorium@gmail.com>

License

Creative Commons Attribution-Share Alike 3.0 Unported
<http://creativecommons.org/licenses/by-sa/3.0/>
